

CASANOVO

Do 370C160

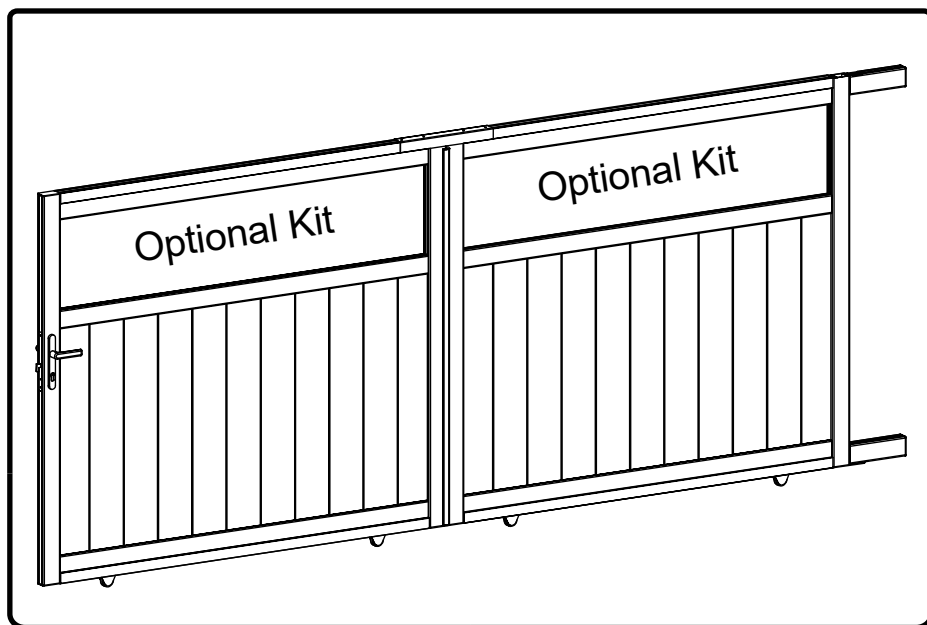

INSTRUCTION MANUAL / NOTICE DE MONTAGE / MONTAGEANLEITUNG / MANUAL DE MONTAJE / MANUAL DE MONTAGEM / MANUALE DI MONTAGGIO /
MONTAGEHANDLEIDING / INSTRUKCJA MONTAŻU / KÄYTTÖOHJEET / BRUKSANVISNING / BRUGSANVISNING / INSTRUCȚIUNI DE ASAMBLARE /
NAVODILA ZA SESTAVLJANJE / NÁVOD NA MONTÁŽ / ÖSSZESZERELÉSI ÚTMUTATÓ / NÁVOD K MONTÁŽI / UPUTE ZA INSTALACIJU /
ΟΔΗΓΙΕΣ ΣΥΝΑΡΜΟΛΟΓΗΣΗΣ / SURINKIMO INSTRUKCIJOS / MONTĀŽAS INSTRUKCIJAS

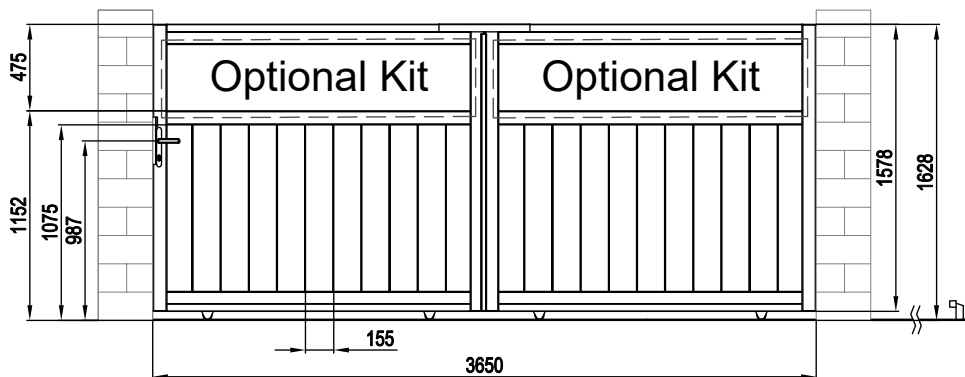

Int.

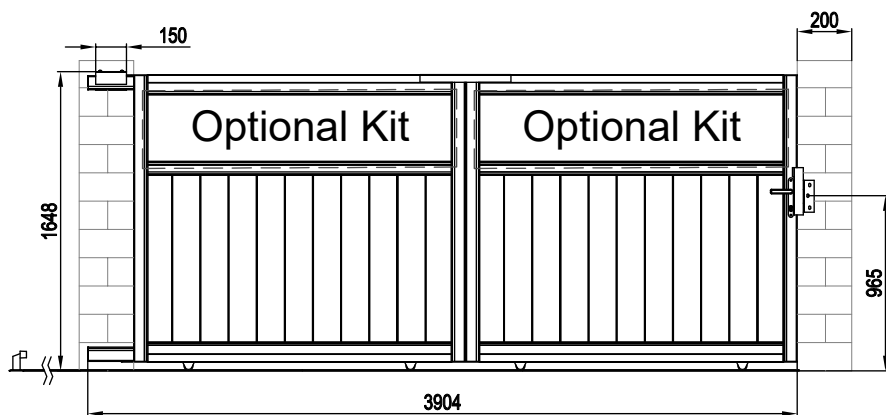

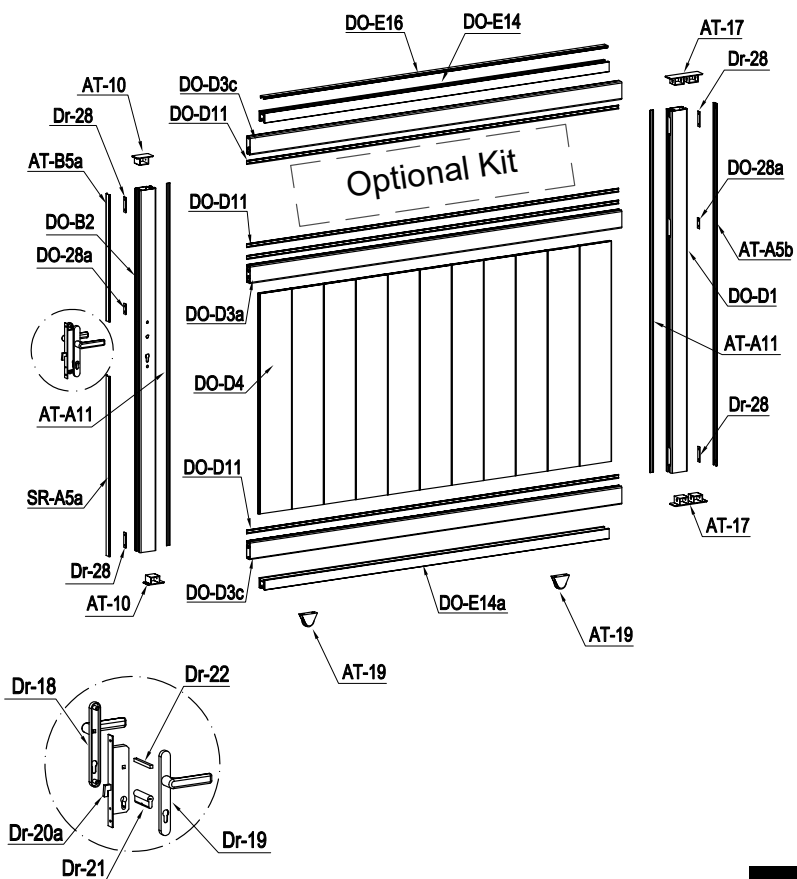
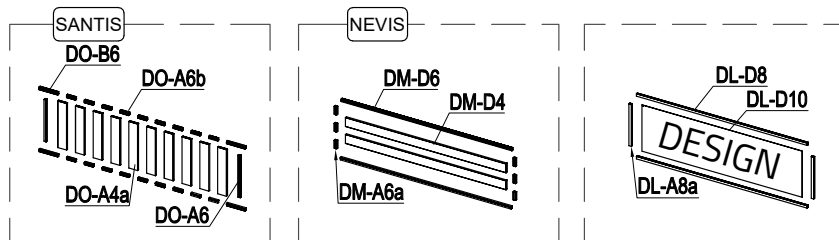

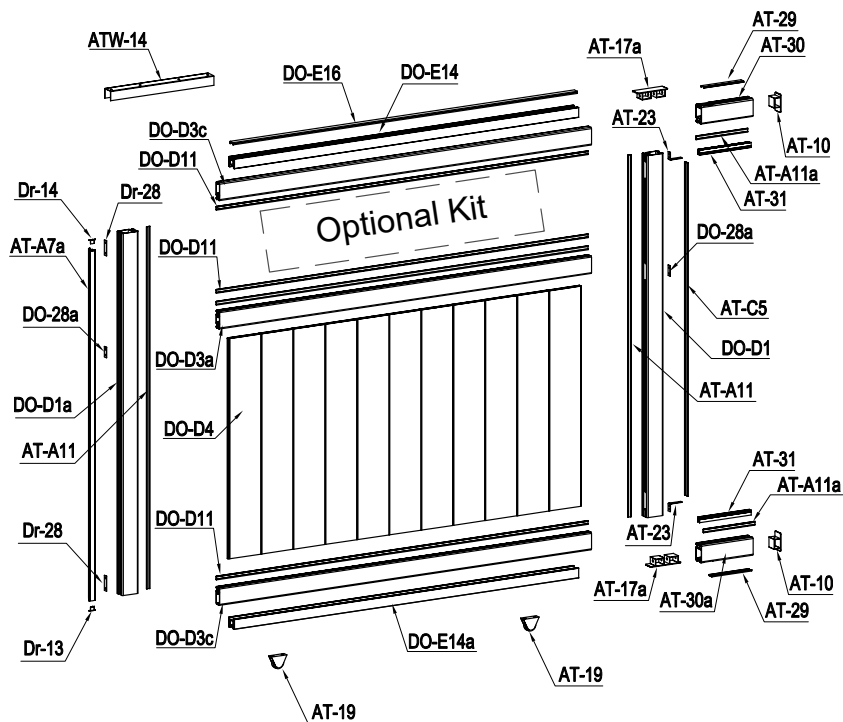
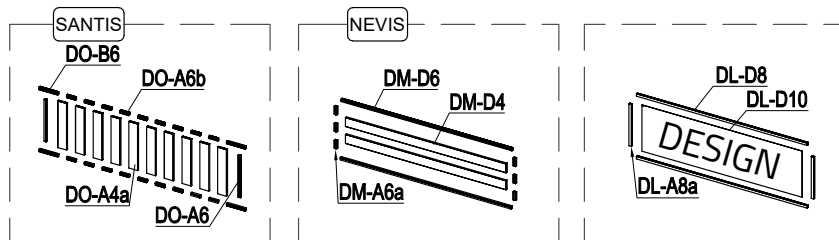

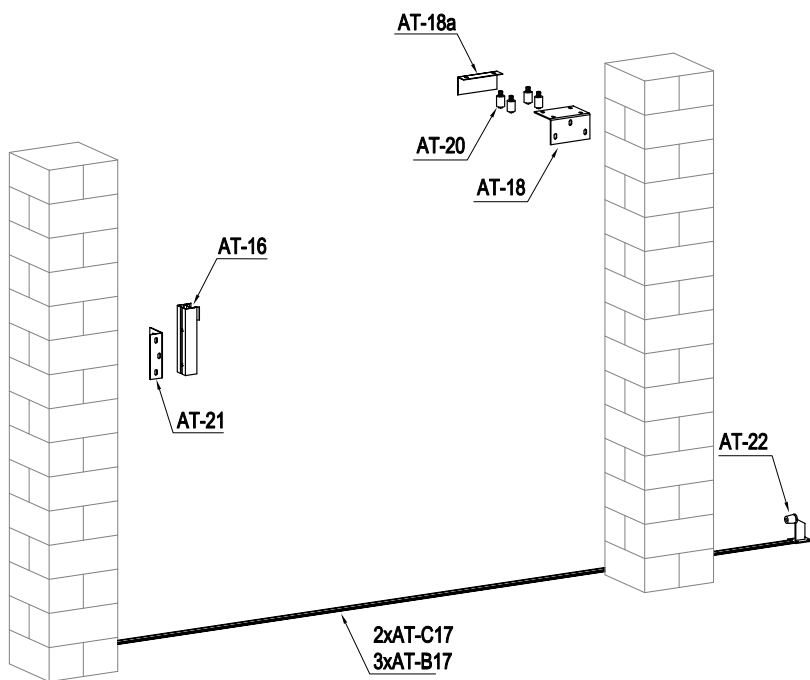













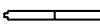













































PARTS LIST

IMAGE	NO.	L.(mm)	QTY	IMAGE	NO.	L.(mm)	QTY
	DO-D1	1573	2		AT-18		1
	DO-D1a	1573	1		AT-18a		1
	DO-B2	1573	1		ATW-14		1
	AT-30	250	1		AT-19		4
	AT-30a	250	1		AT-20		4
	DO-D3c	1802	4		AT-21		1
	DO-D3a	1802	2		AT-22		1
	DO-D4	957	22		AT-23		2
	AT-A5b	1573	1		Dr-18		1
	AT-C5	1448	1		Dr-19		1
	AT-B5a	550.5	1		Dr-20a		1
	SR-A5a	782	1		Dr-21		1
	AT-29	193	2		Dr-22		1
	AT-A11	1573	4		Dr-25		1
	AT-A11a	250	2		Dr-25a		2
	DO-D11	1802	8		Dr-27		2
	AT-31	250	2		Dr-28		6
	AT-A7a	1520	1		DO-28a		4
	DO-E14	1668	2		AT-22J		7
	DO-E14a	1668	2		DO-G30	ST4x10	4
	DO-E16	1667	2		DO-G31	ST5.5x38	40
	AT-16		1		DO-G32	ST4.8x38	16
	AT-B17	1412	3		DO-G33	M8x60	10
	AT-C17	1580	2		DO-G34	ST4x25	50
	AT-17		2		DO-G35	ST4.2x19	50
	AT-17a		2		DO-G36	M6x20	2
	AT-10		4		DO-G37	M8x20	8
	Dr-13		1		DO-G38	M8x130	4
	Dr-14		1				
	DO-30		8				

PARTS LIST (Optional Kit)

	IMAGE	NO.	L.(mm)	QTY
		DO-A4a	406	20
		DO-A6	364	4
		DO-B6	163	8
		DO-A6b	77.5	36
	DO-35		40	

	IMAGE	NO.	L.(mm)	QTY
		DM-D4	1710	4
		DM-D6	1800	4
		DM-A6a	69	12
		DO-32		8

	IMAGE	NO.	L.(mm)	QTY
		DL-D8	1800	4
		DL-A8a	364	4
		DL-D10	1707	2
		DO-32		8
		DO-35		24

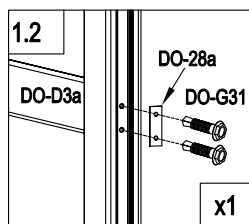
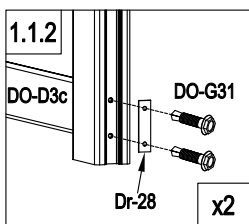
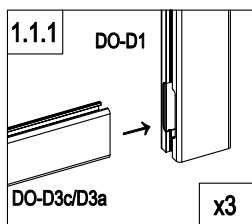
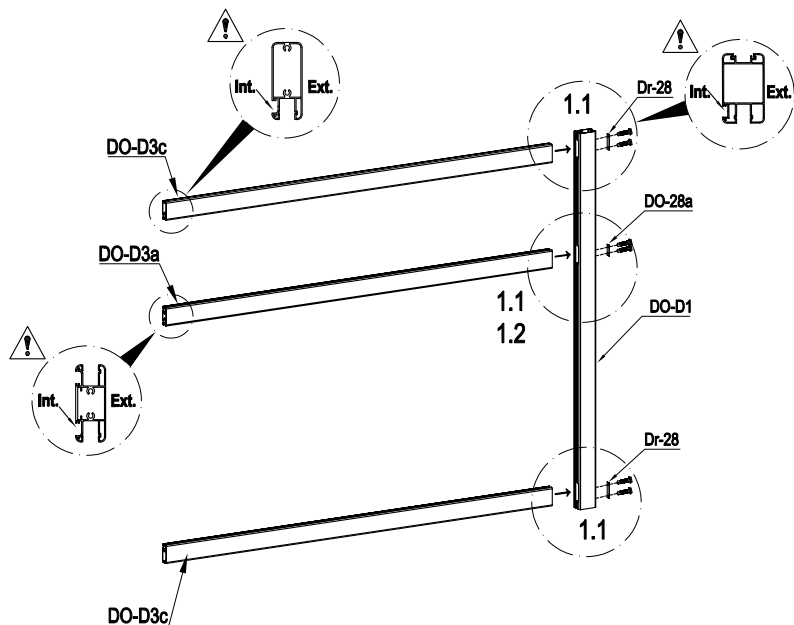

	DO-D1	1
	DO-D3c	2
	DO-D3a	1

	Dr-28	2
	DO-28a	1
	DO-G31	6

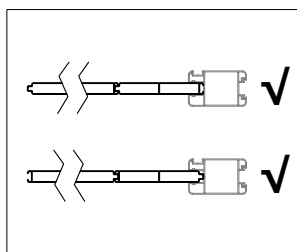
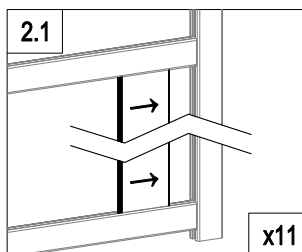
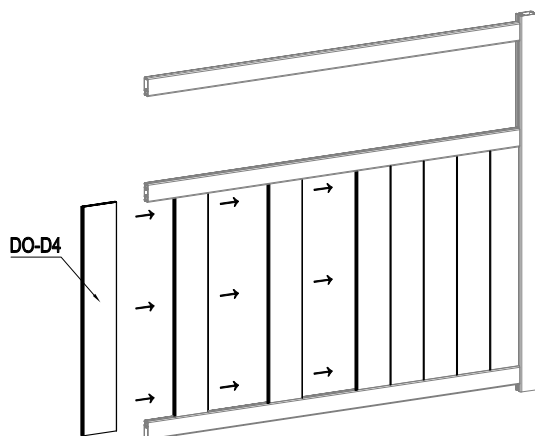

	DO-D4	11
---	-------	----

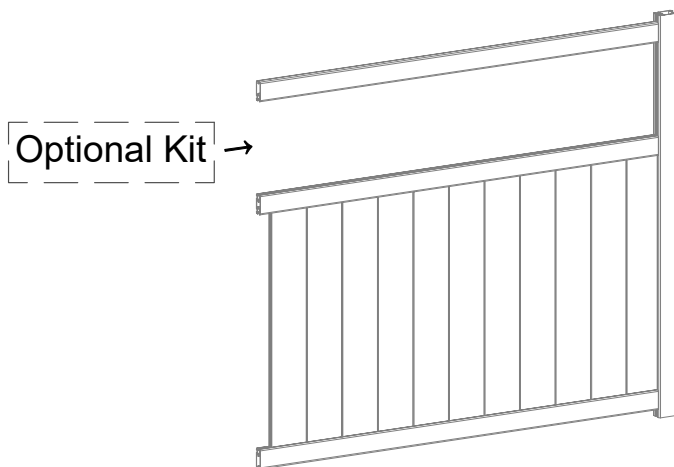

P 11~14



P 15~18



P 19~21

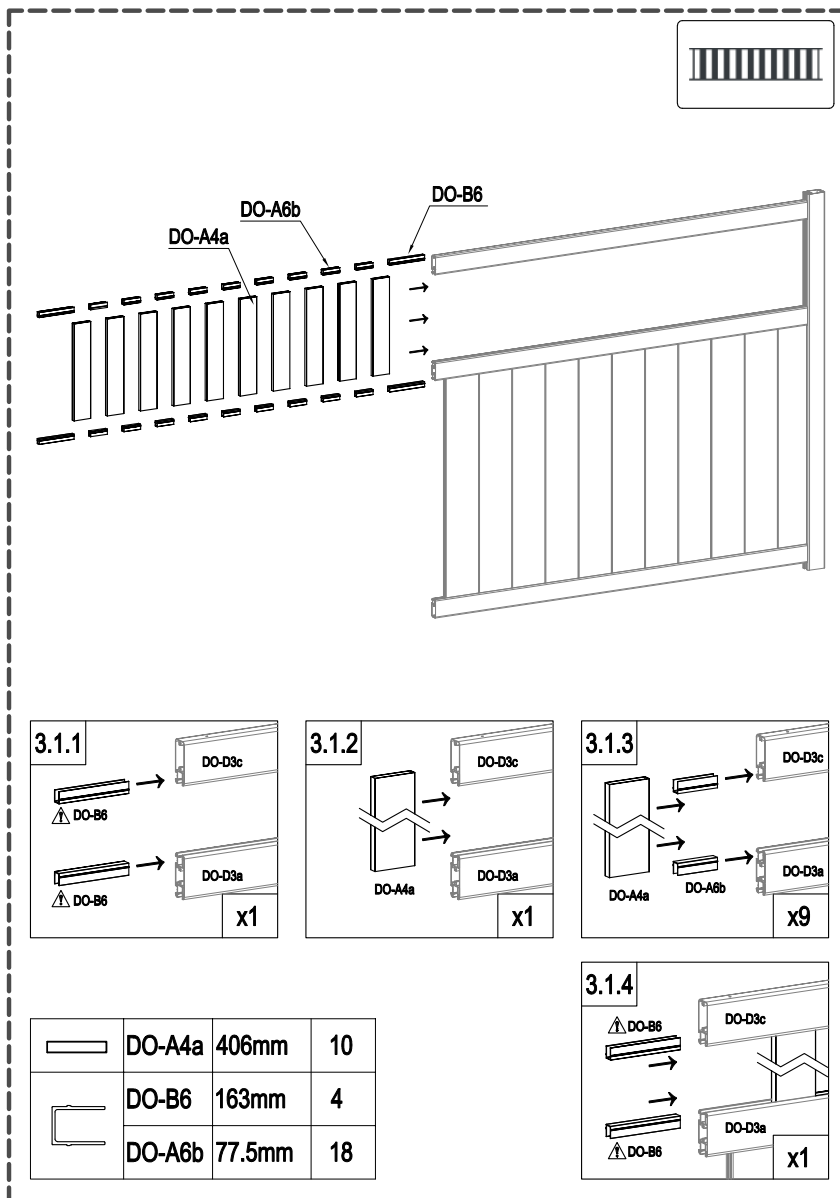

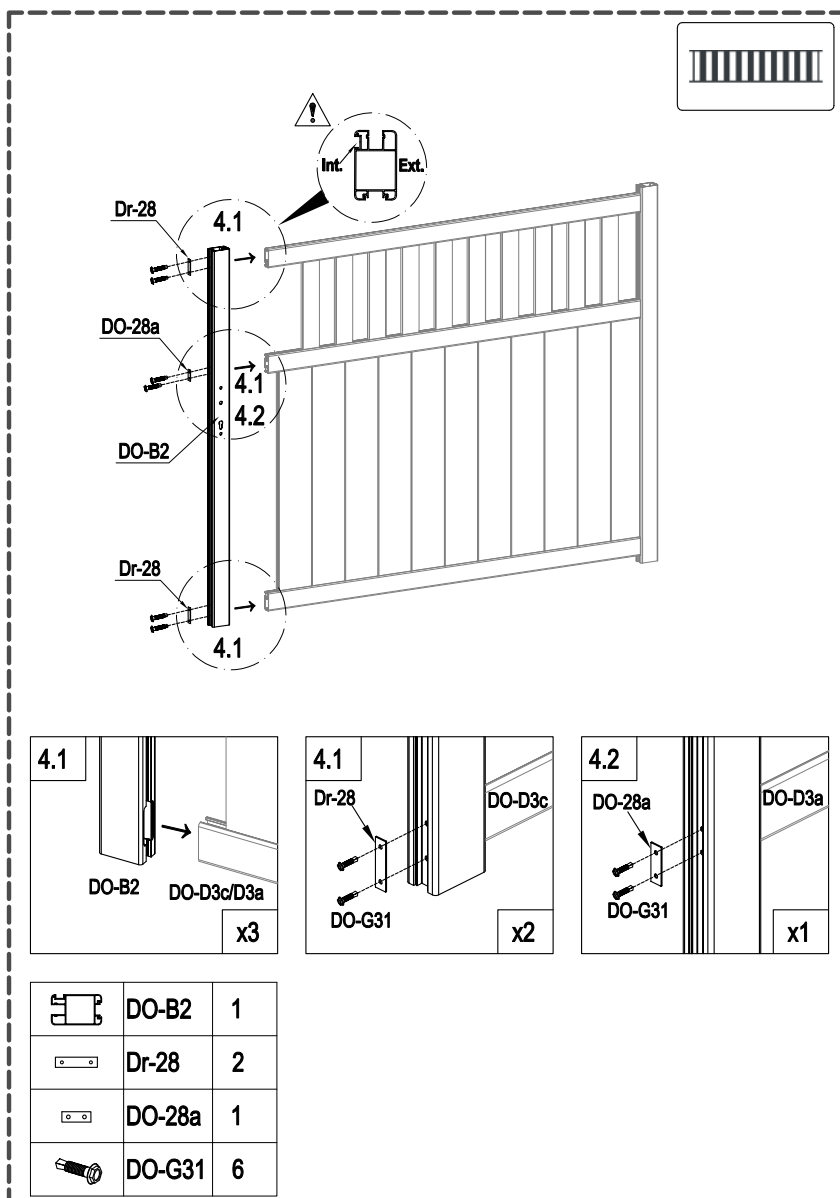

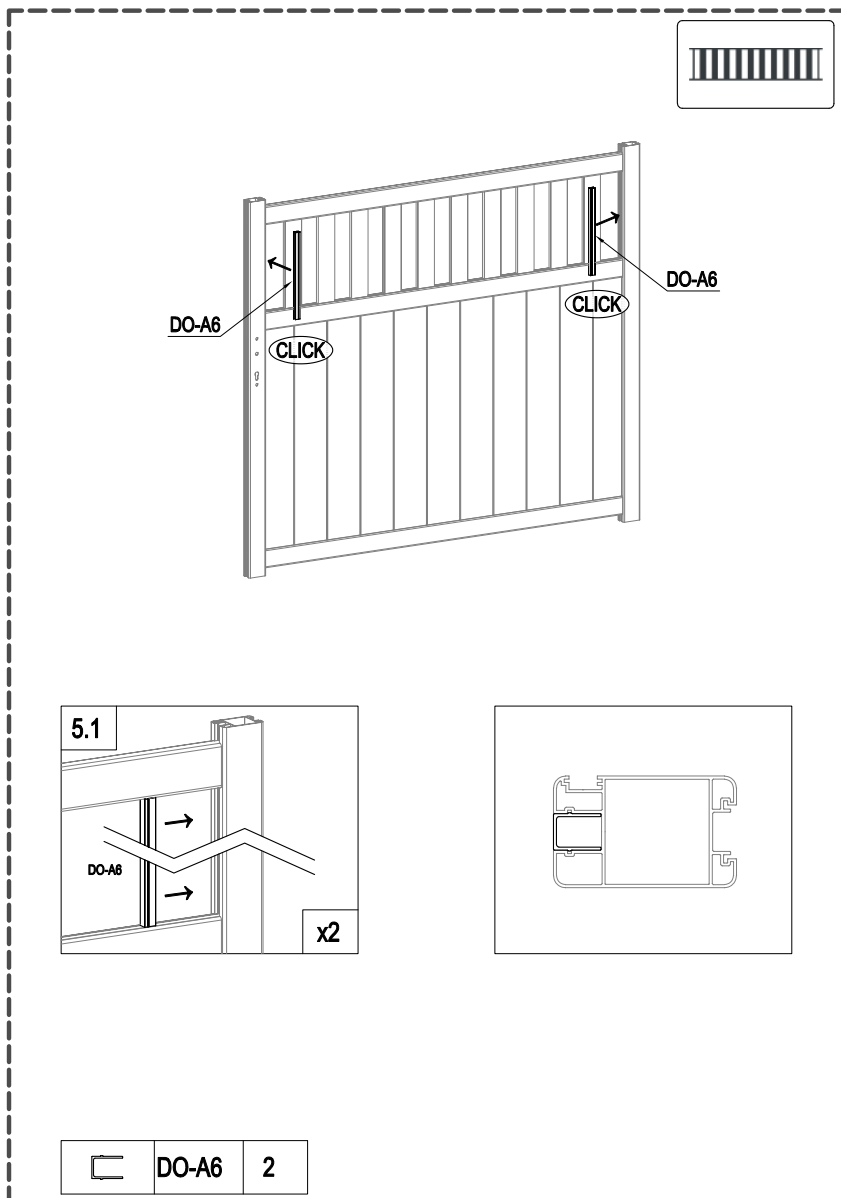

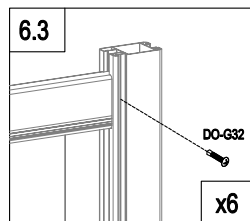
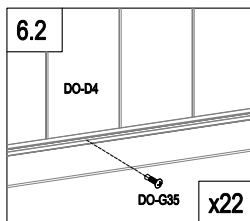
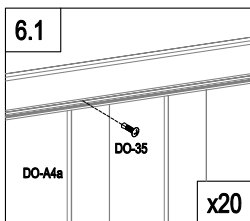
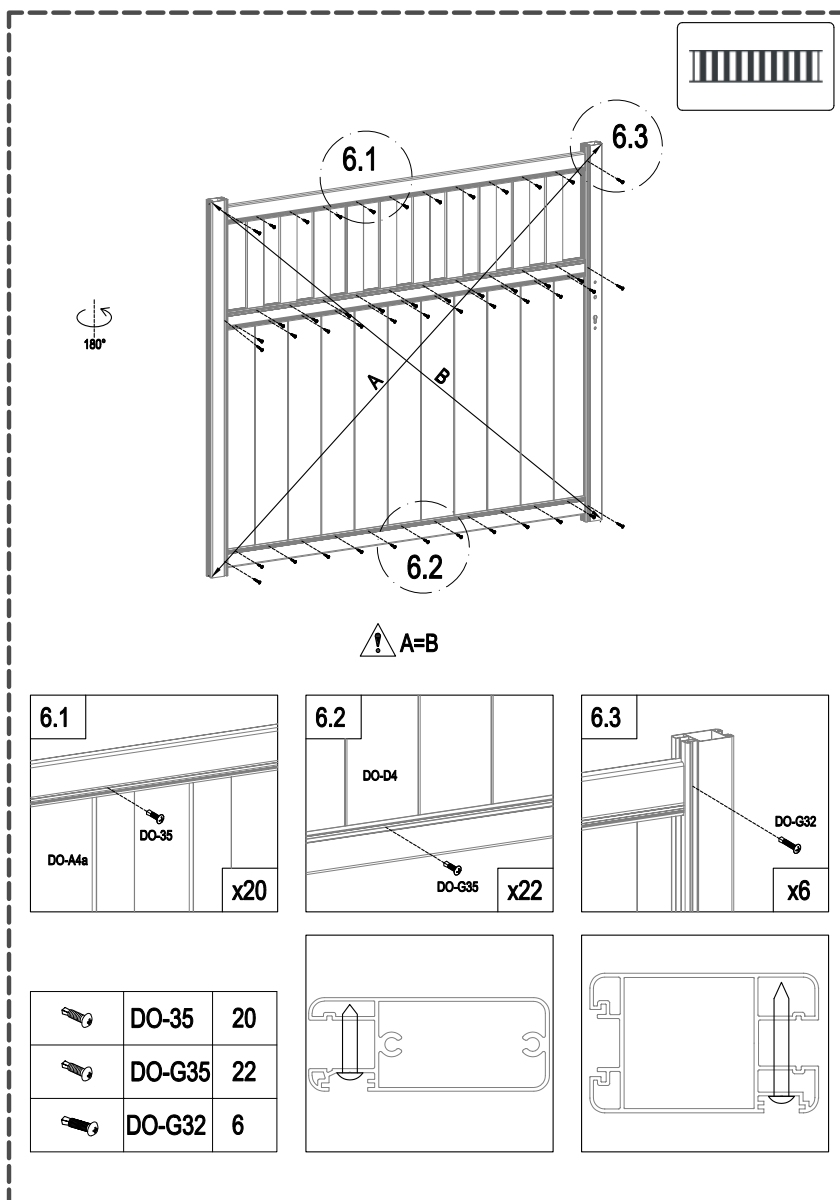

	DO-35	20
	DO-G35	22
	DO-G32	6

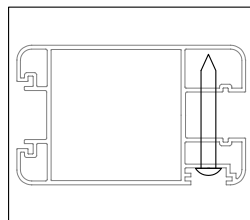
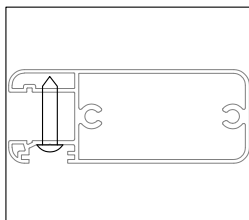

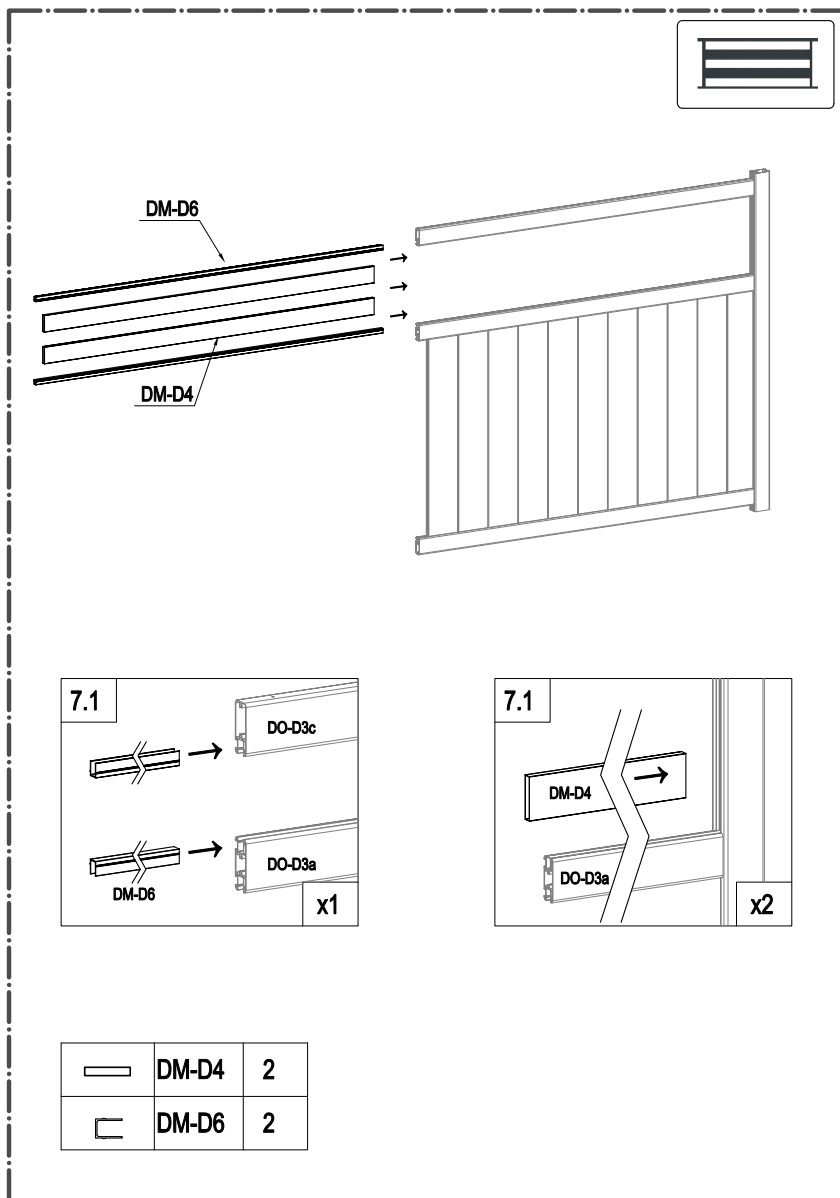

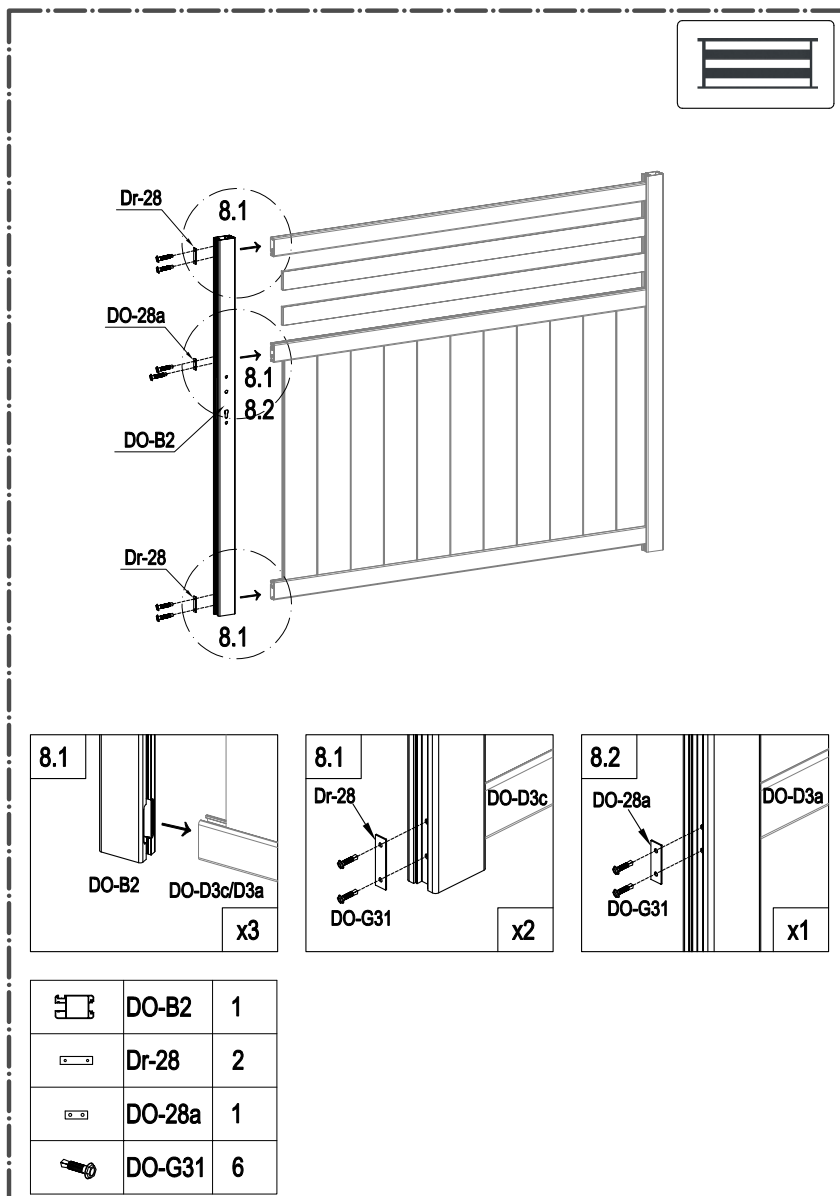

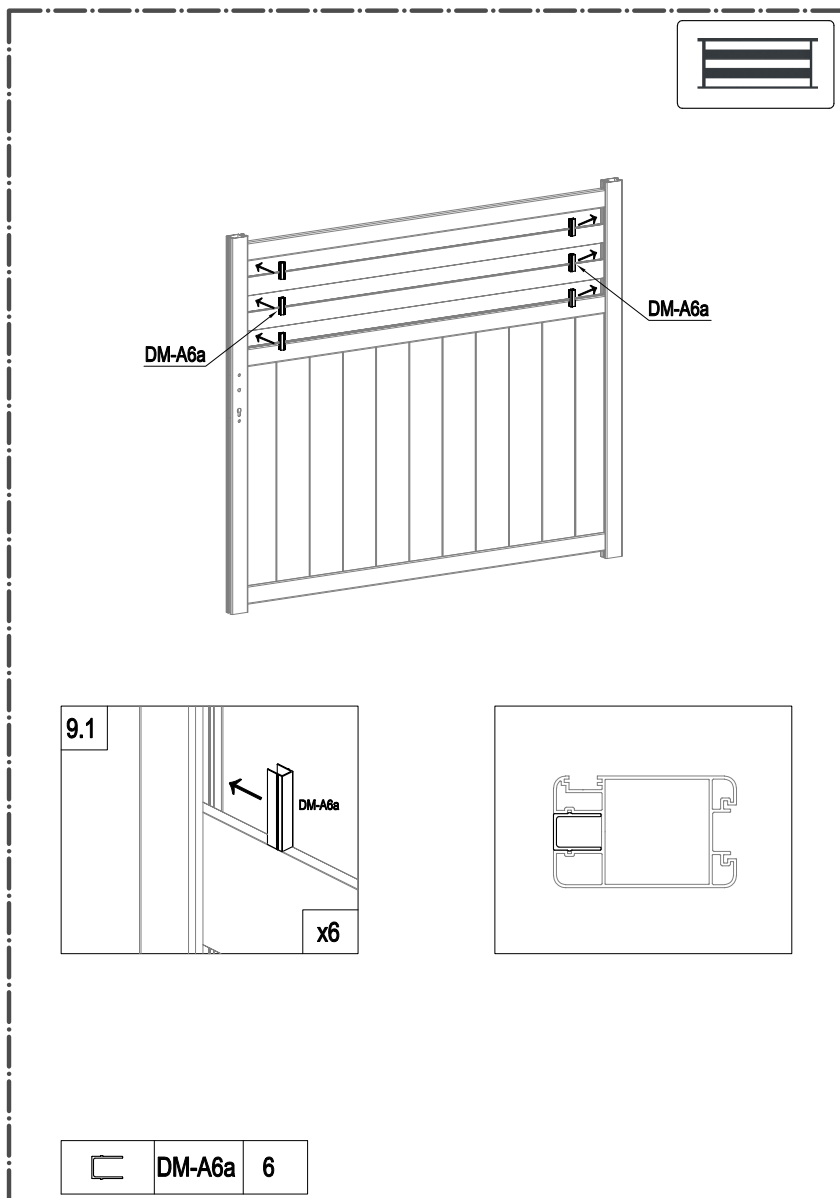

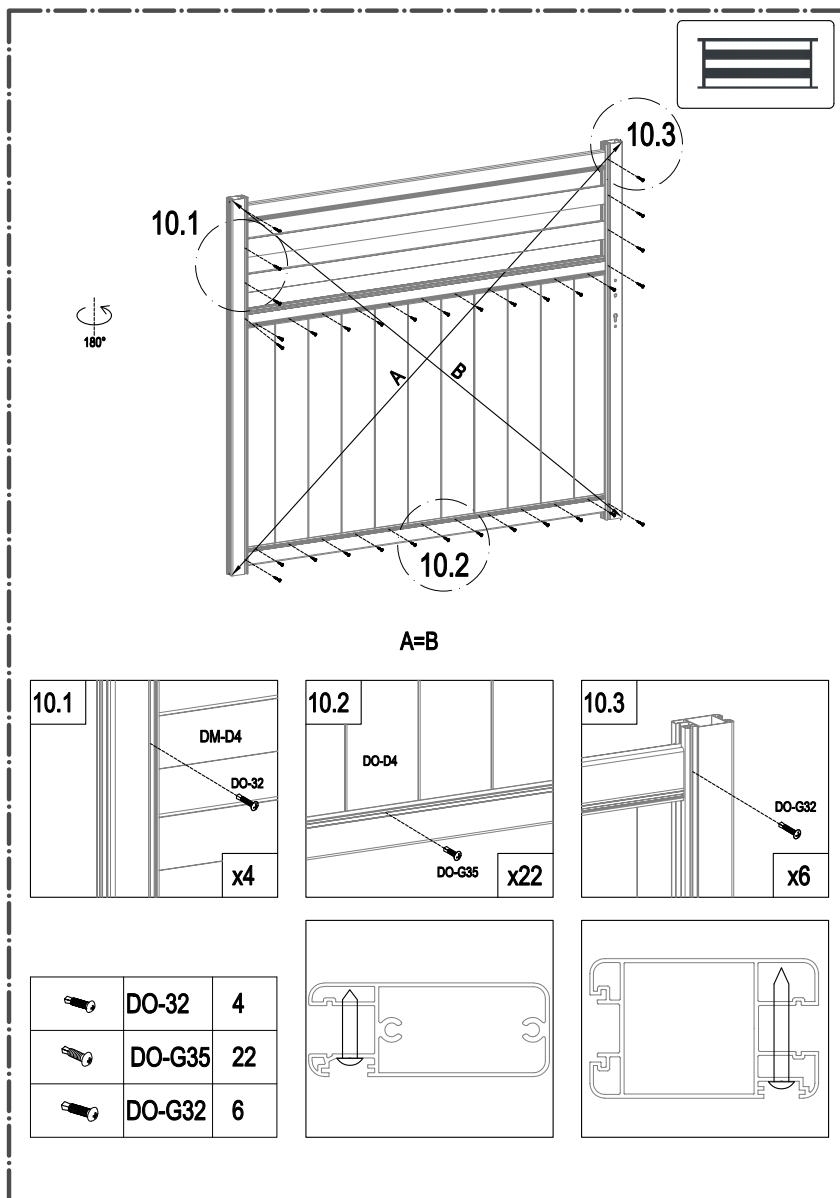

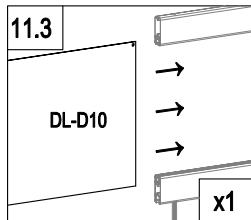
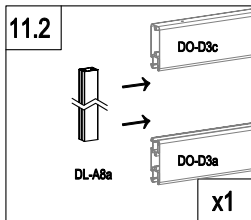
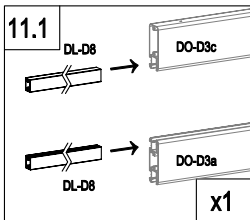
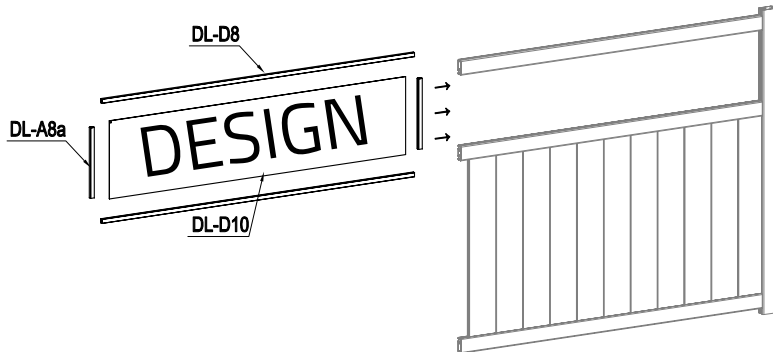

DESIGN



DESIGN	DL-D10	1
	DL-D8	2
	DL-A8a	2

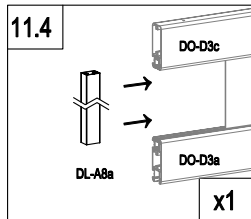

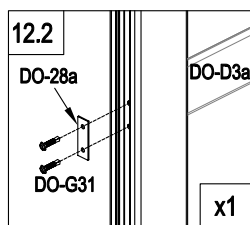
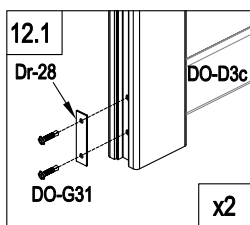
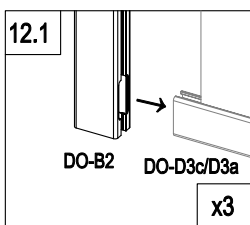
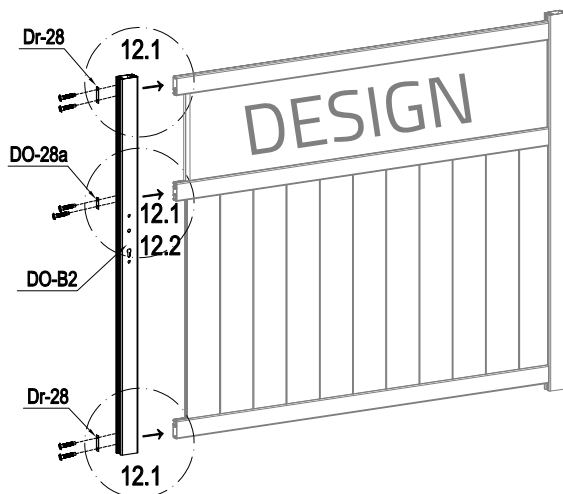

DESIGN



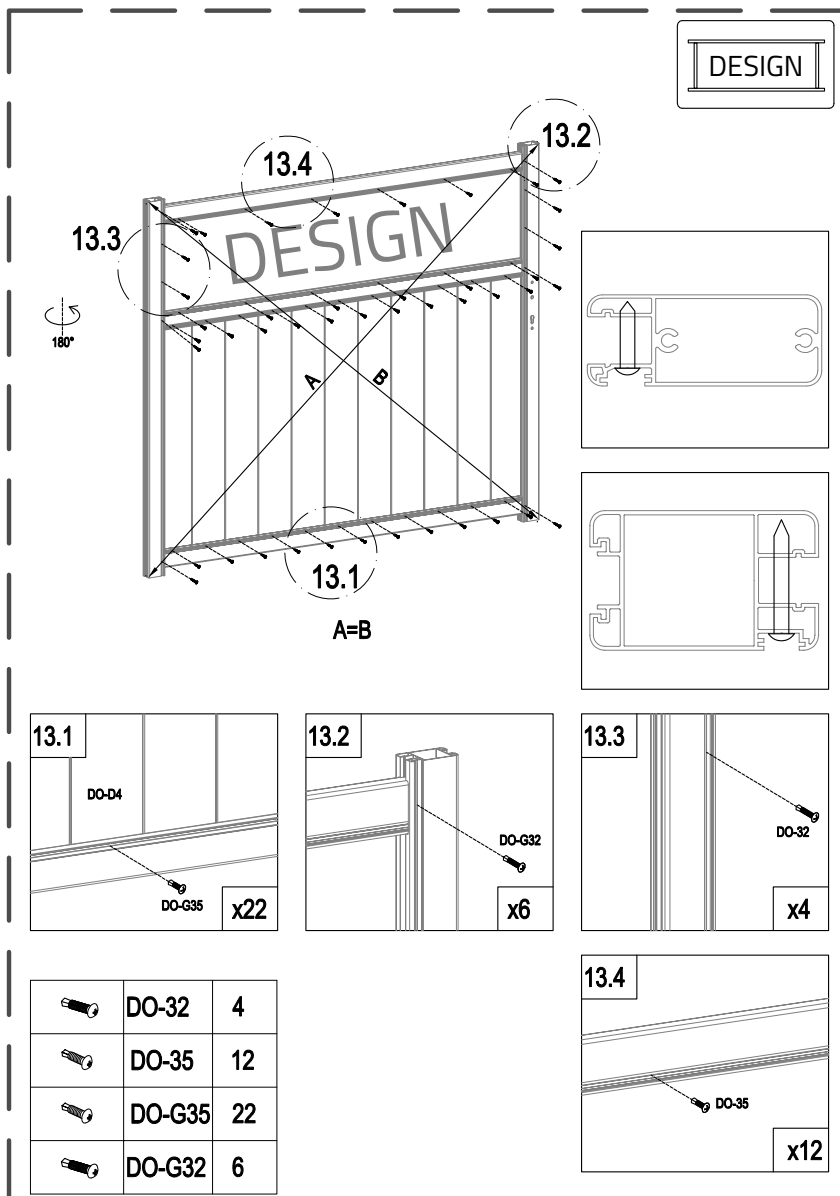

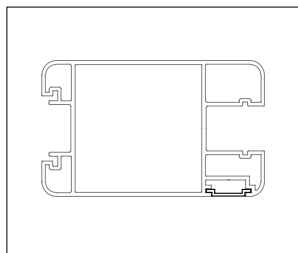
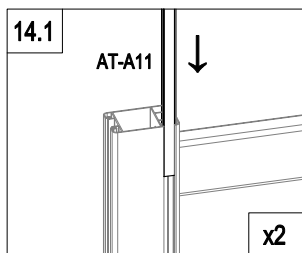
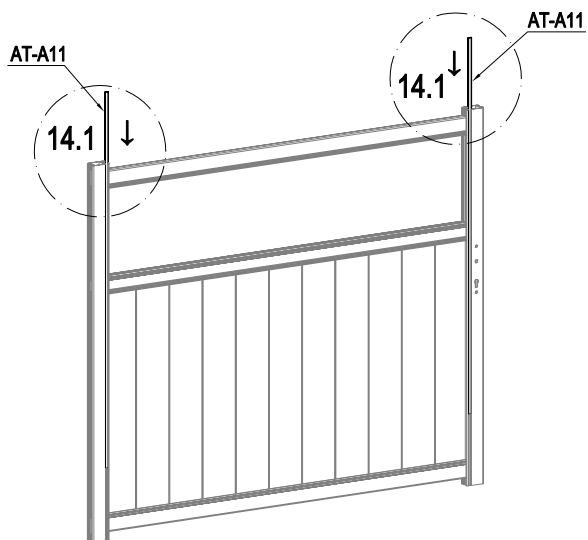
	DO-B2	1
	Dr-28	2
	DO-28a	1
	DO-G31	6



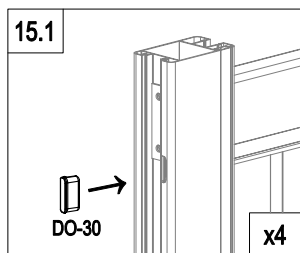
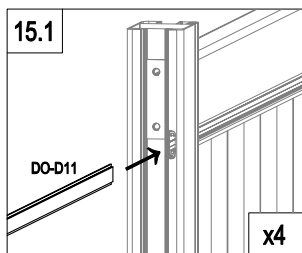
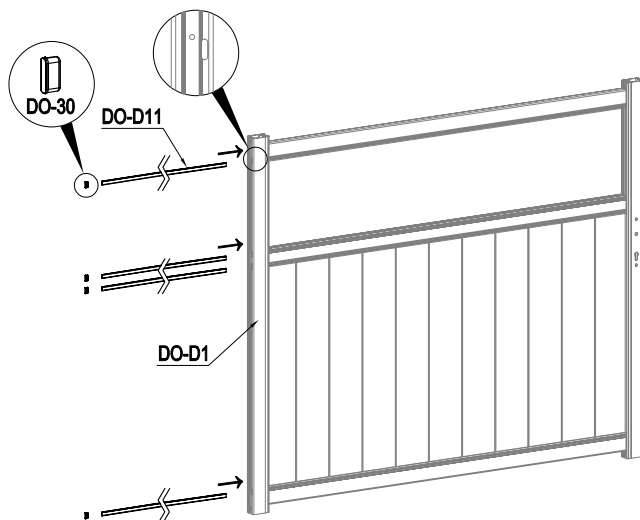

	AT-A11	2
---	--------	---



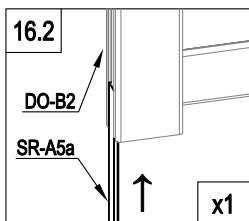
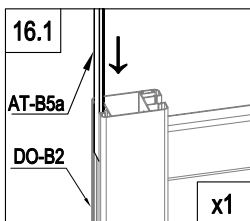
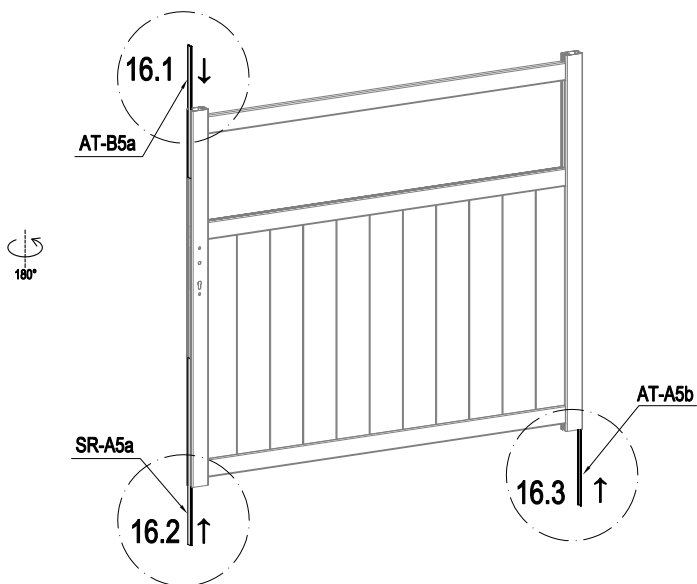

	DO-D11	4
	DO-30	4

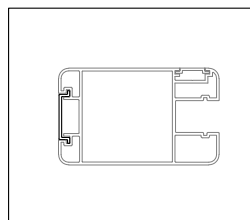

	AT-A5b	1
	AT-B5a	1
	SR-A5a	1

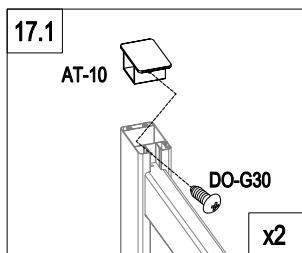
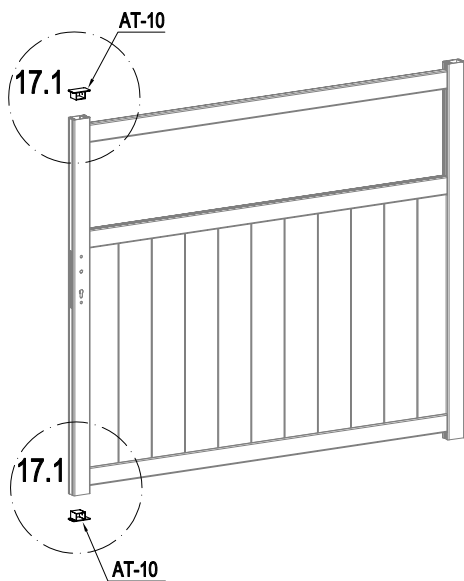



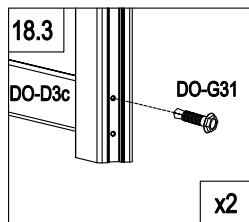
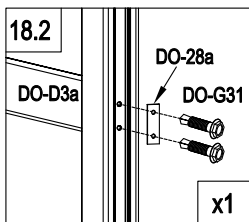
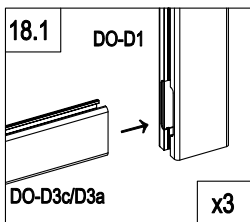
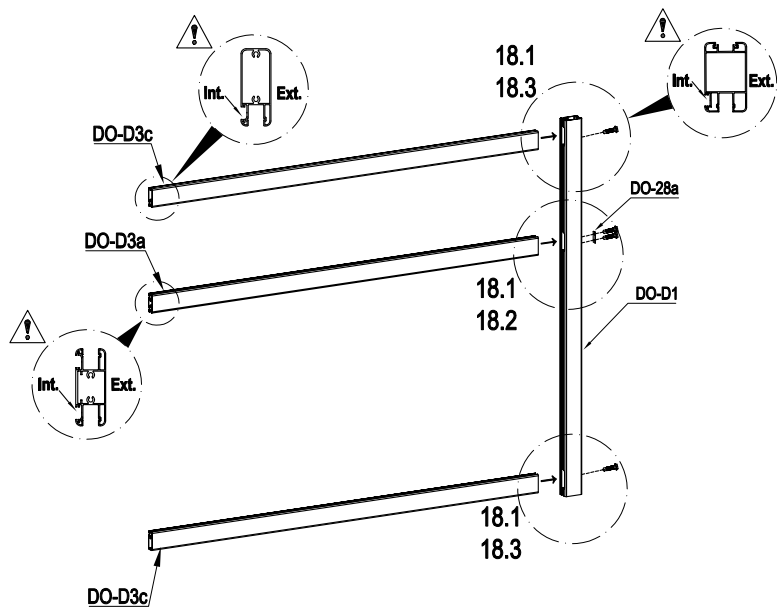

	AT-10	2
	DO-G30	2

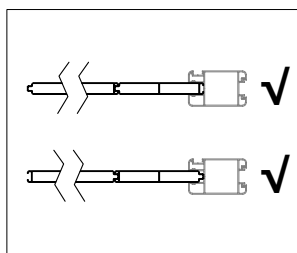
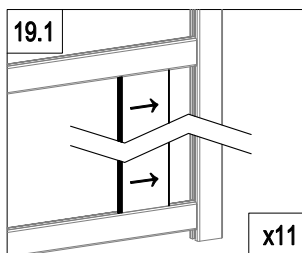
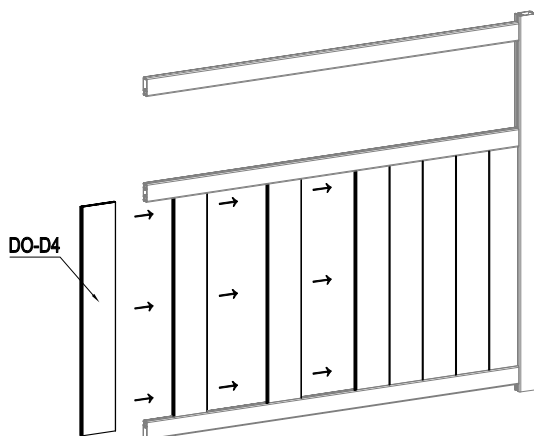

	DO-D1	1
	DO-D3c	2
	DO-D3a	1

	DO-28a	1
	DO-G31	4



	DO-D4	11
---	-------	----

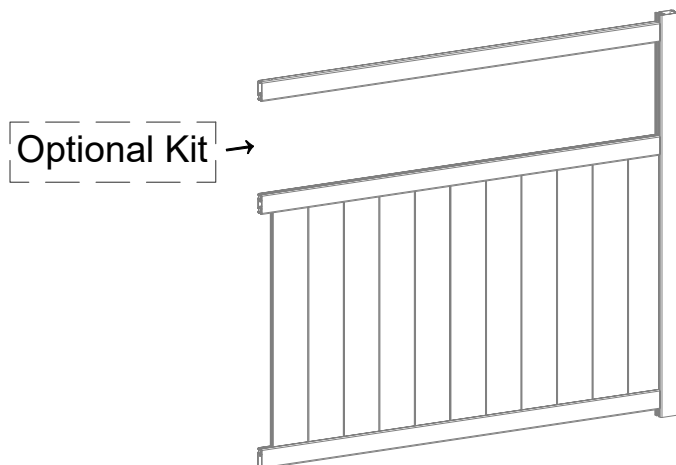

P 29~32



P 33~36



P 37~39

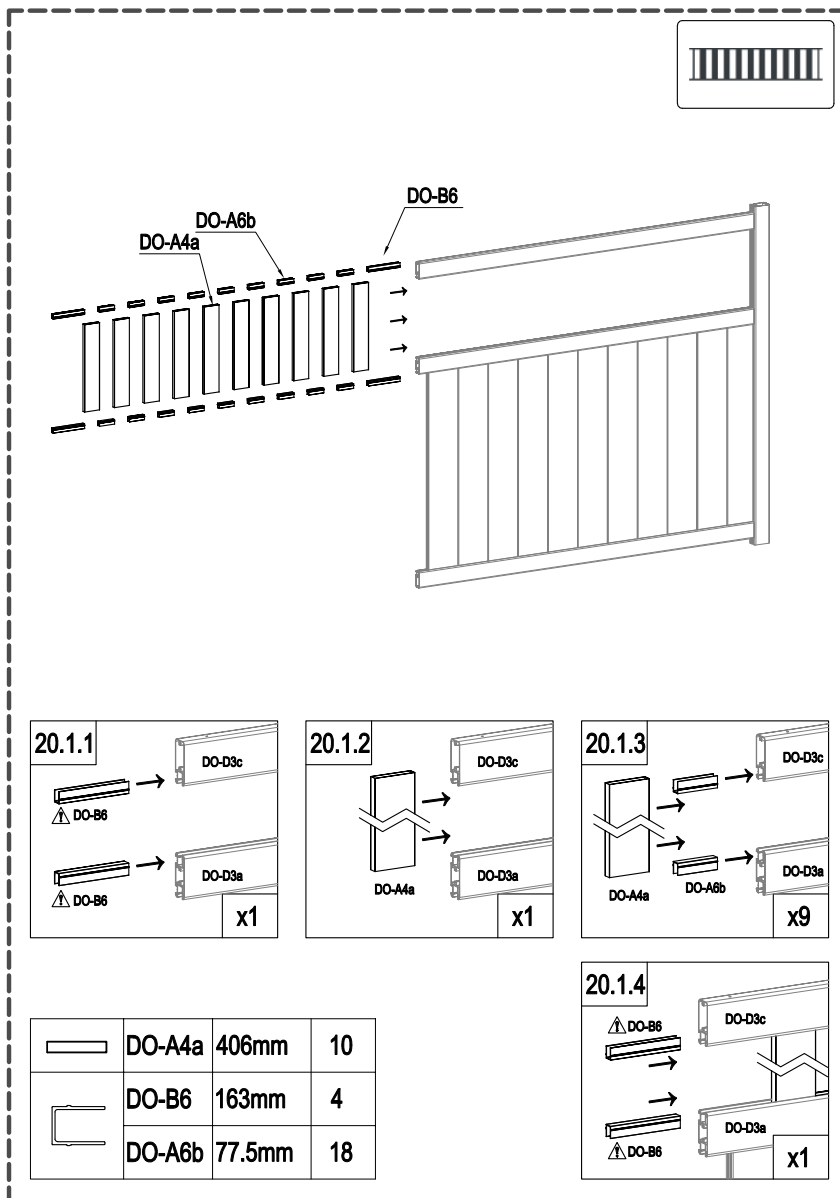

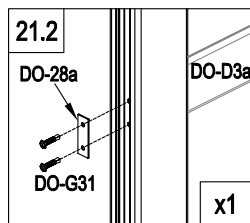
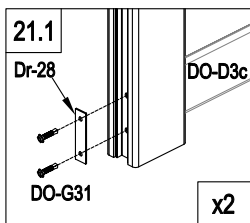
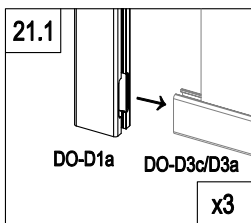
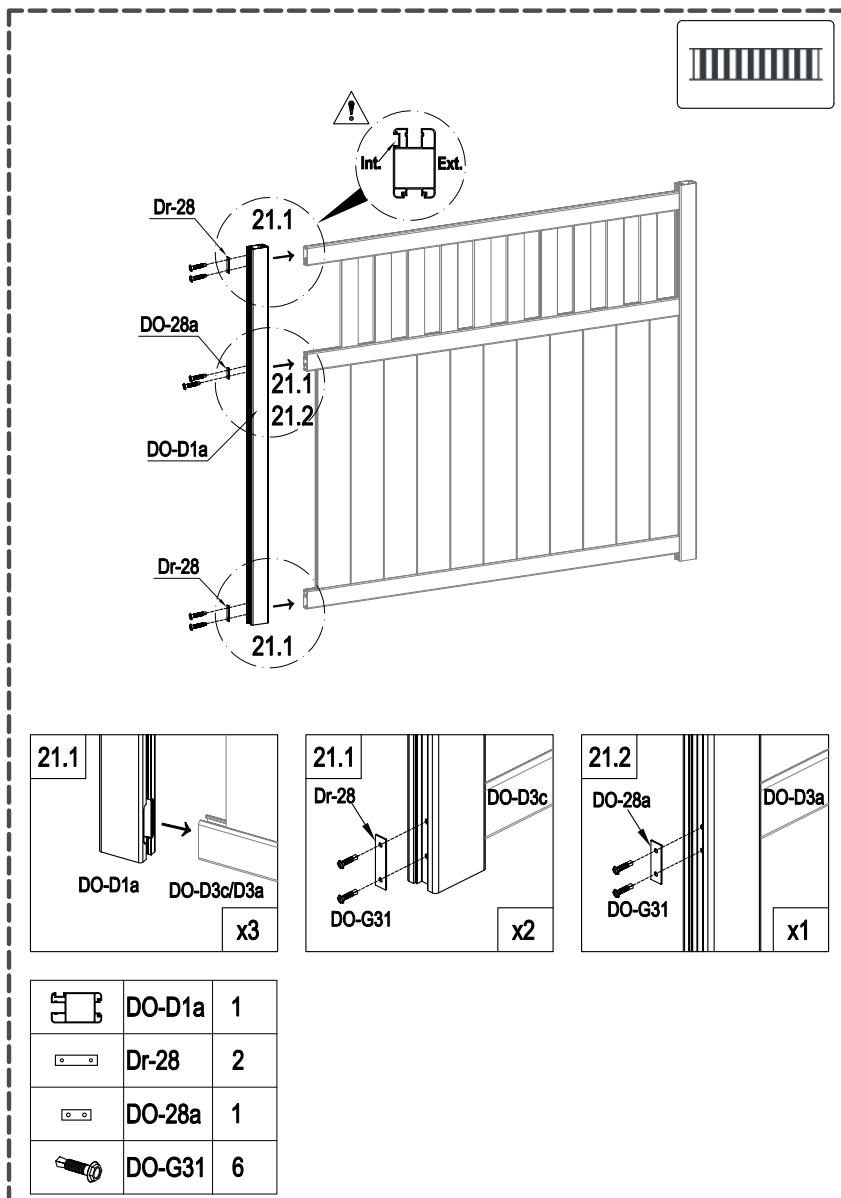

	DO-D1a	1
	Dr-28	2
	DO-28a	1
	DO-G31	6

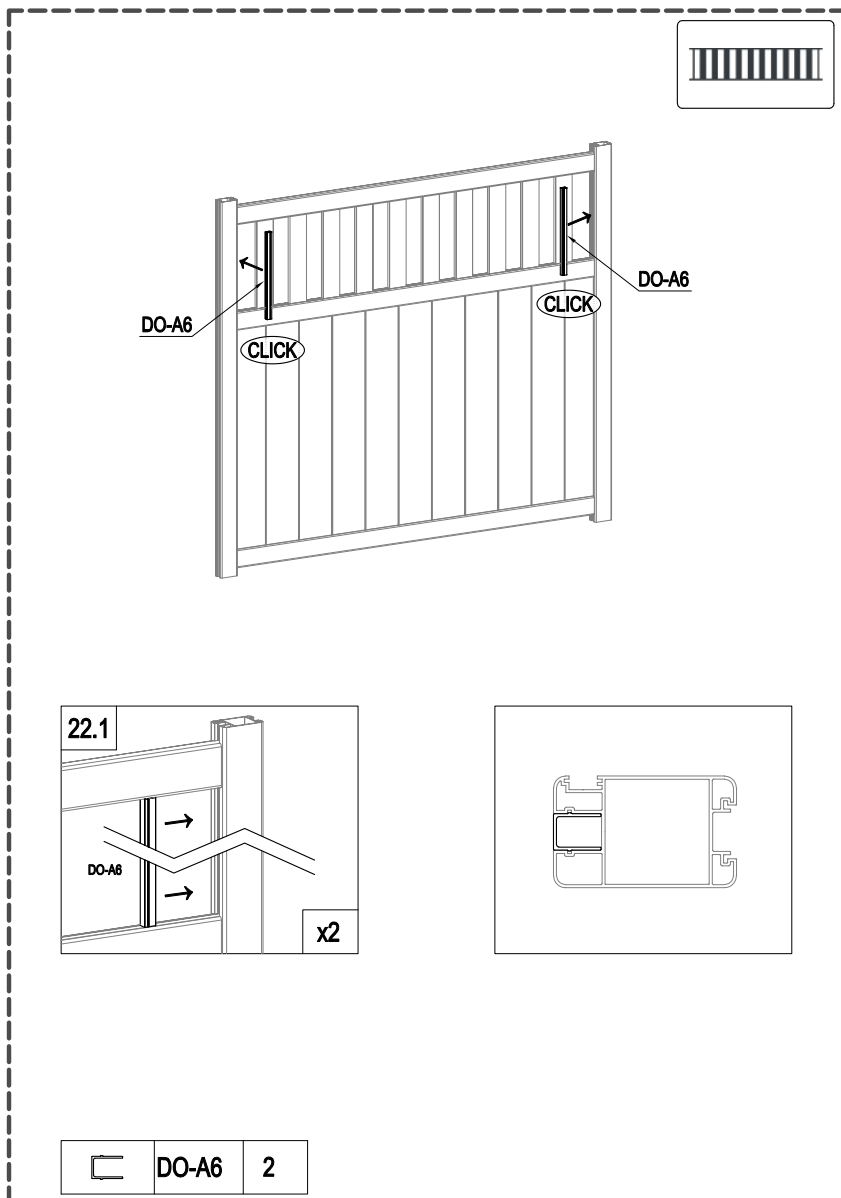

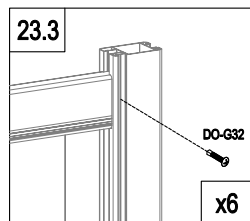
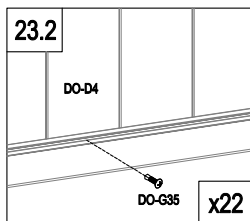
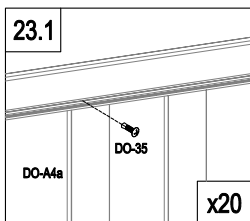
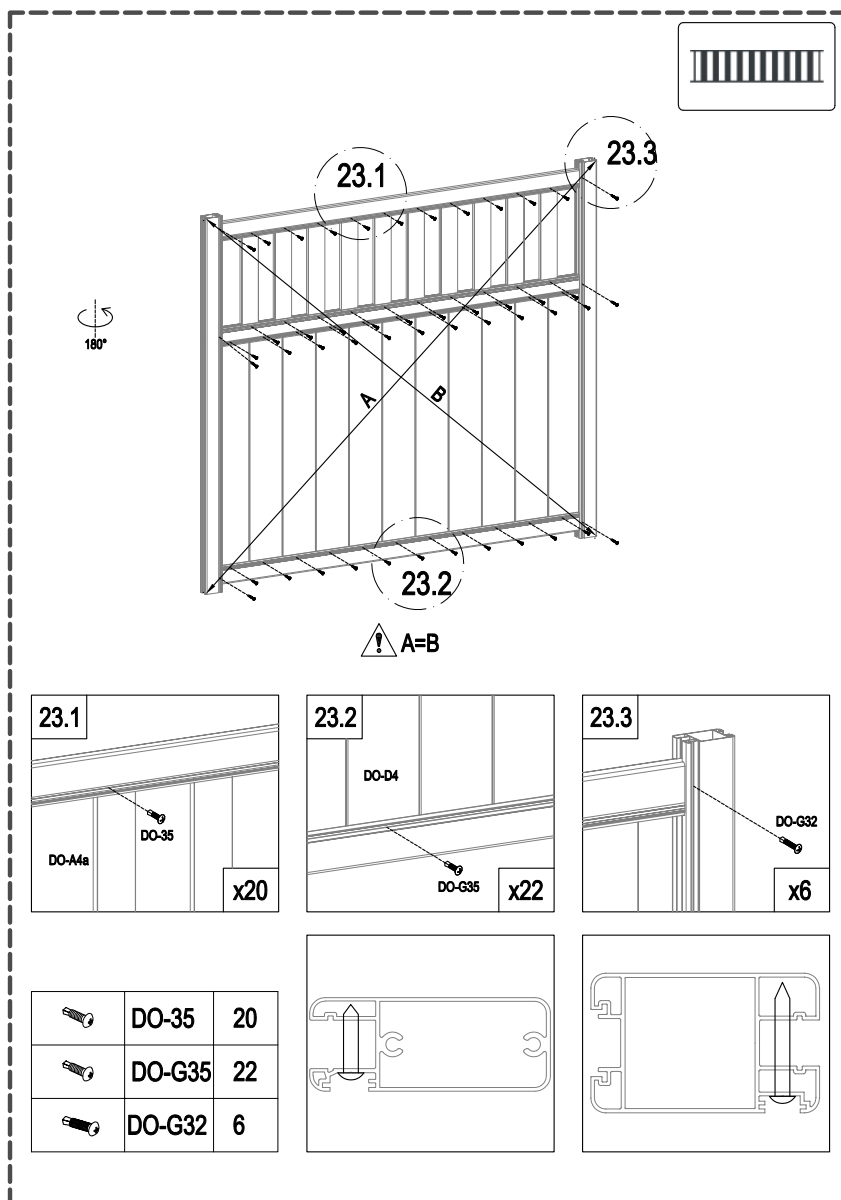

	DO-35	20
	DO-G35	22
	DO-G32	6

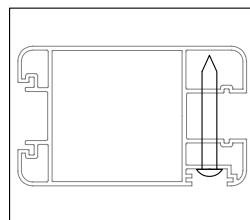
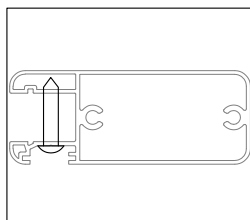

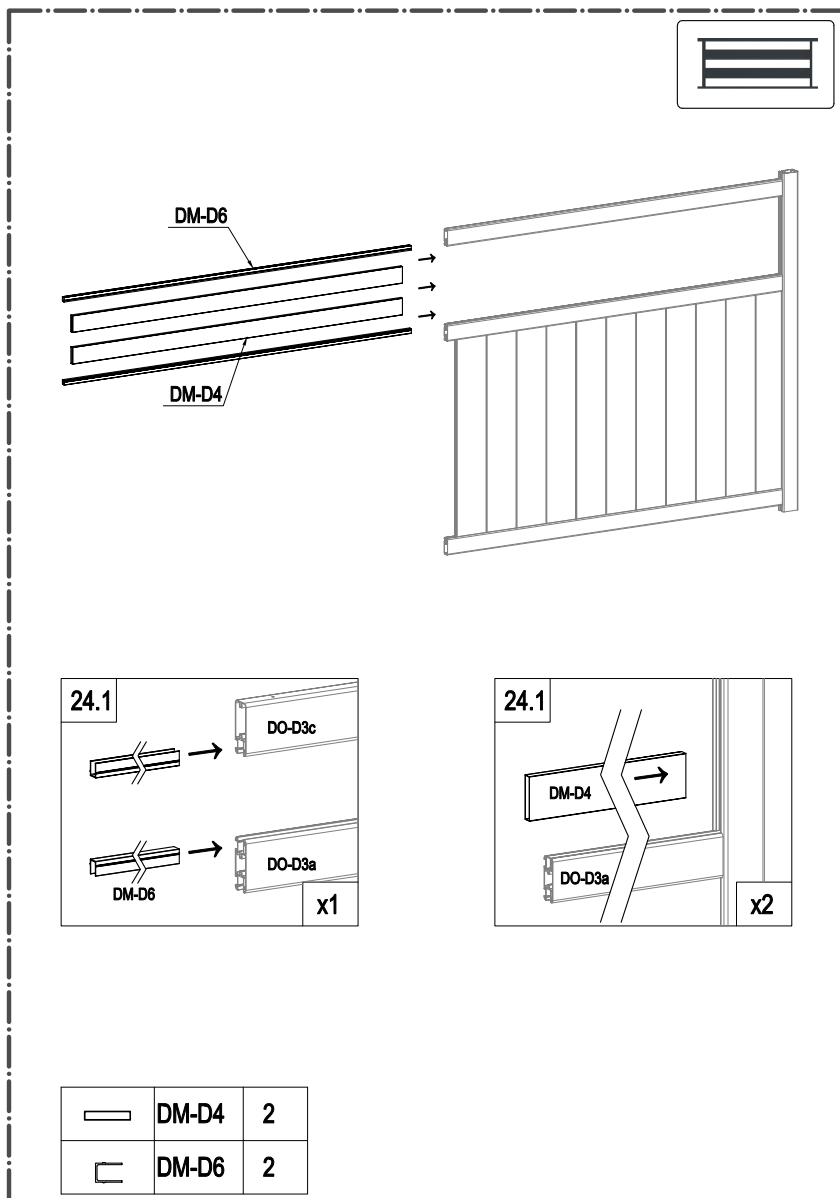

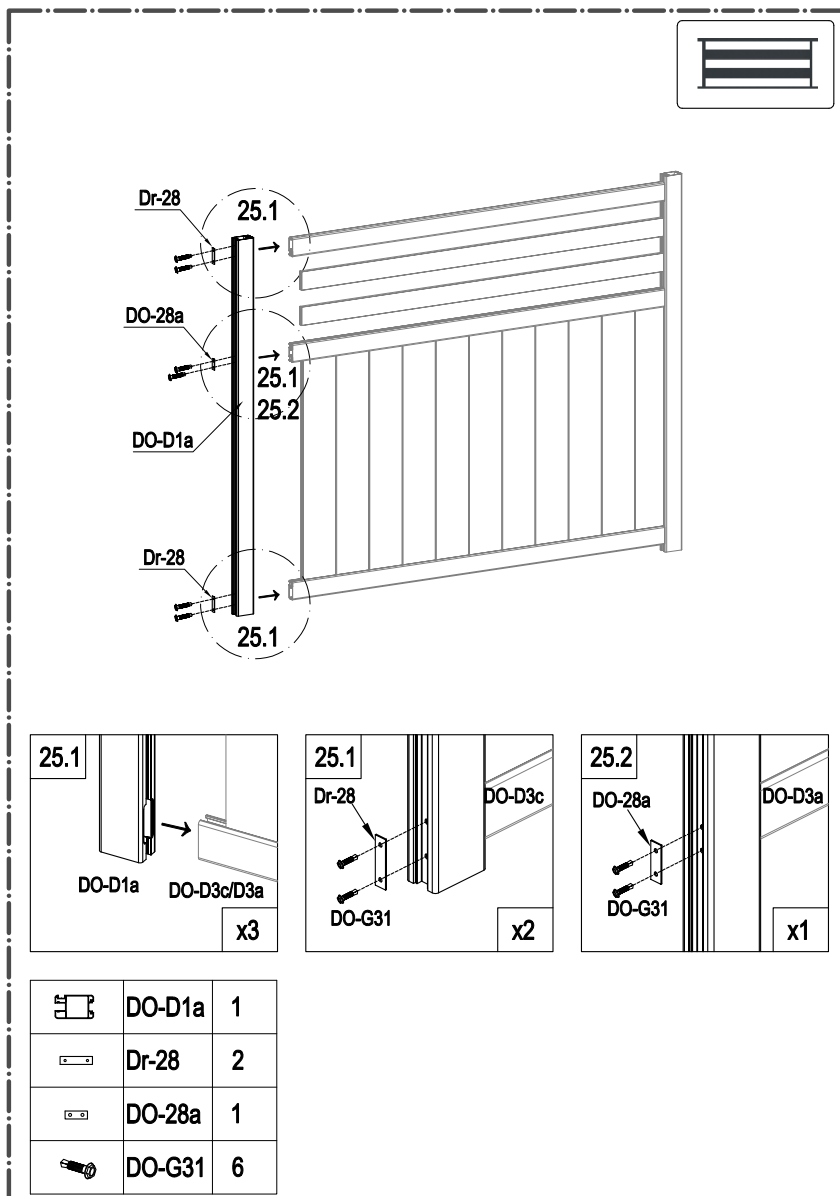

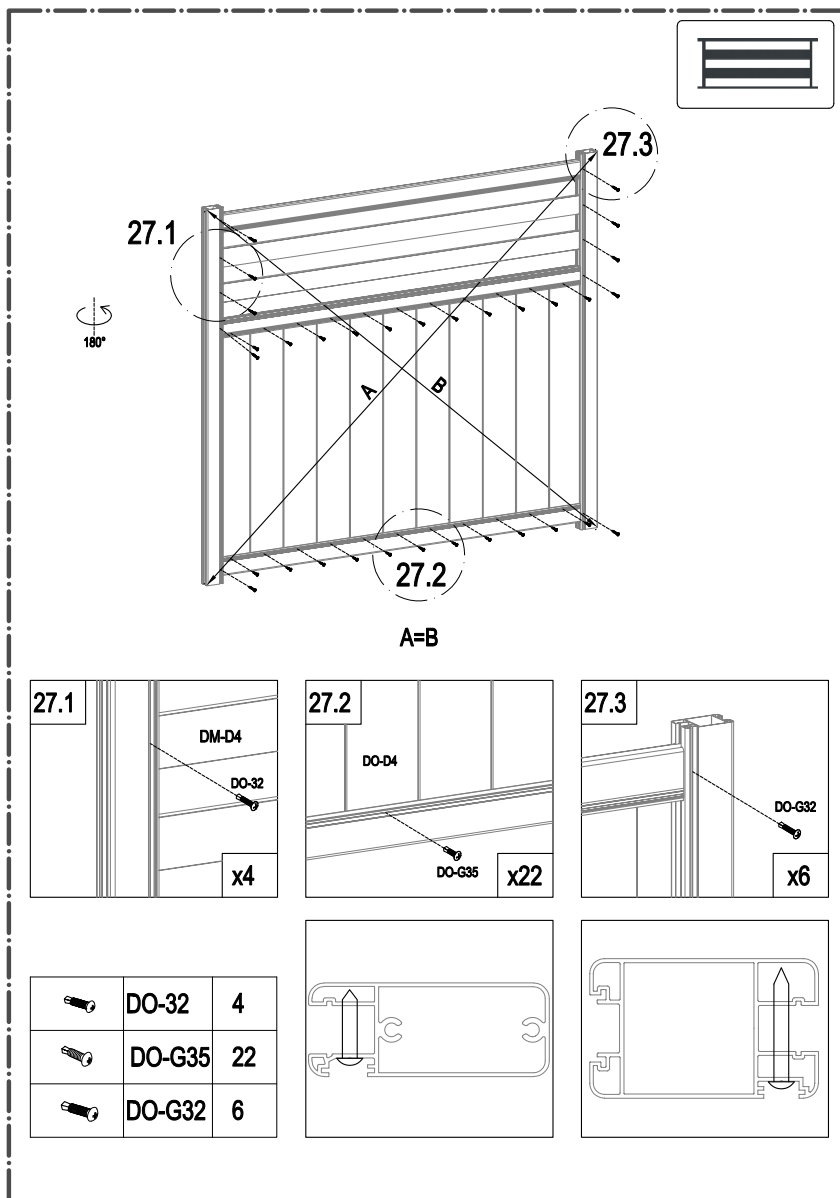

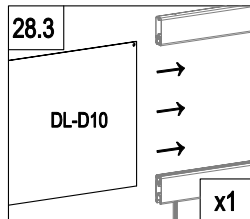
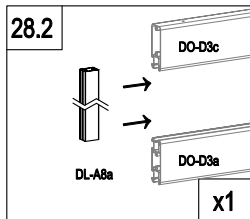
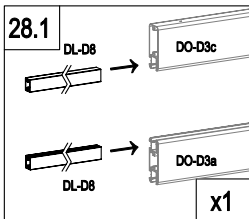
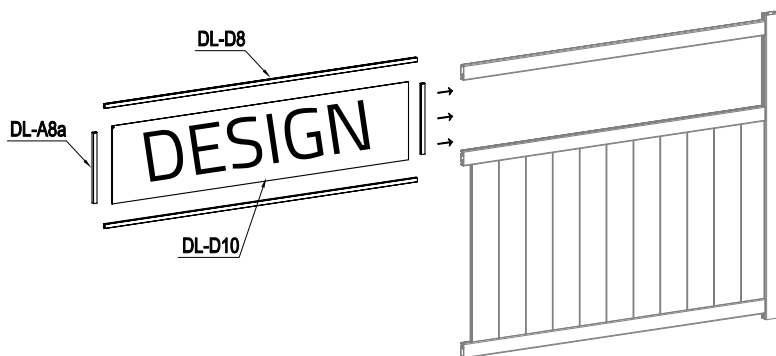

DESIGN





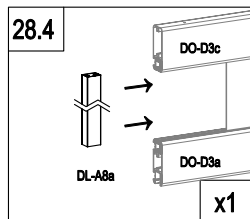

DESIGN	DL-D10	1
	DL-D8	2
	DL-A8a	2

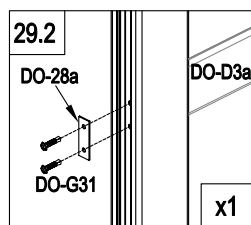
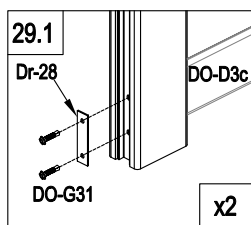
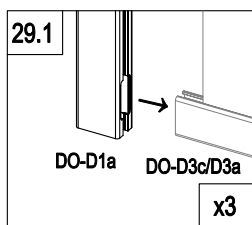
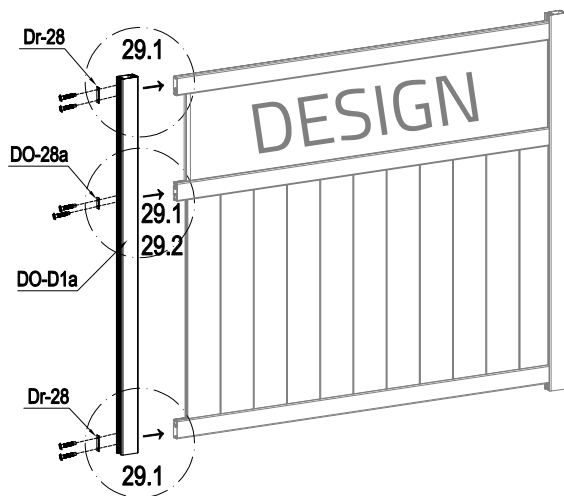



DESIGN



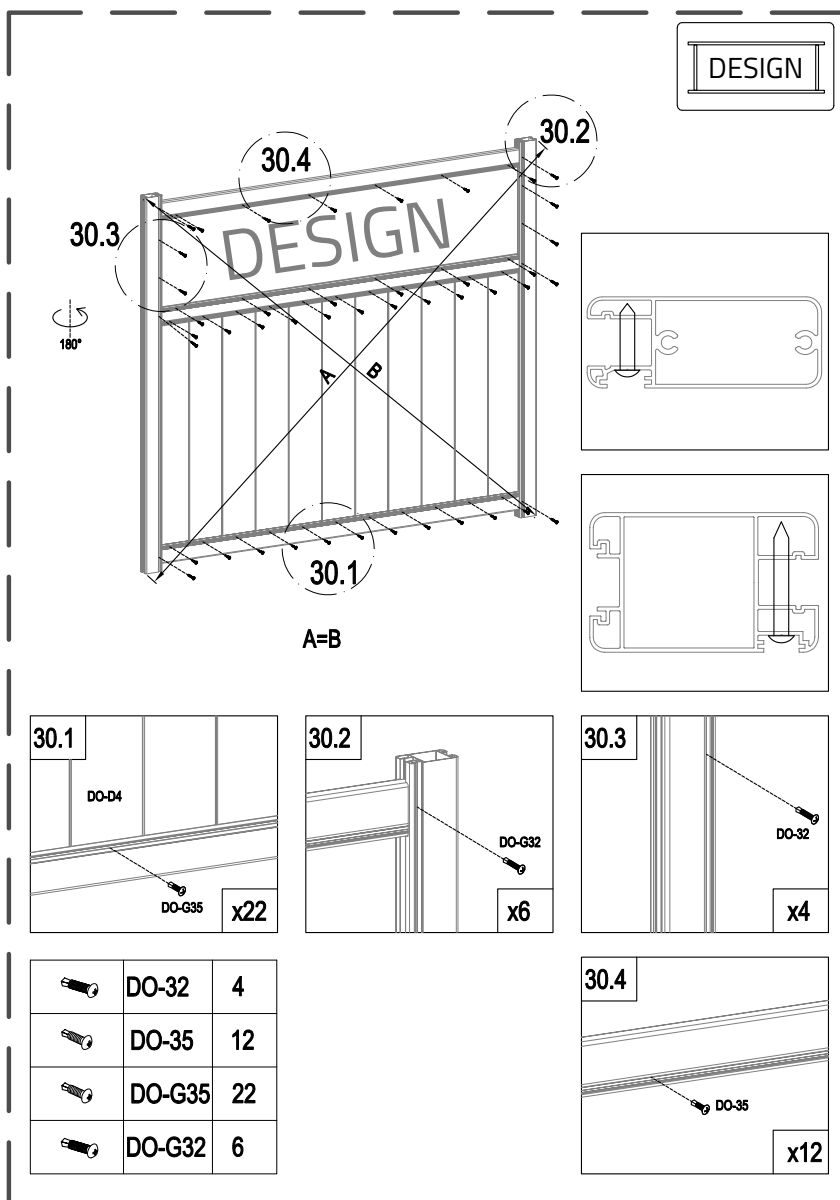

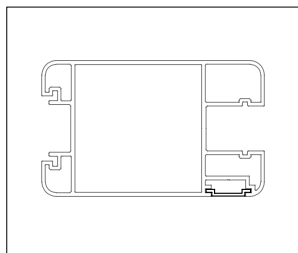
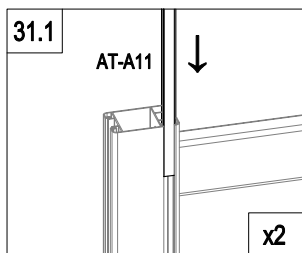
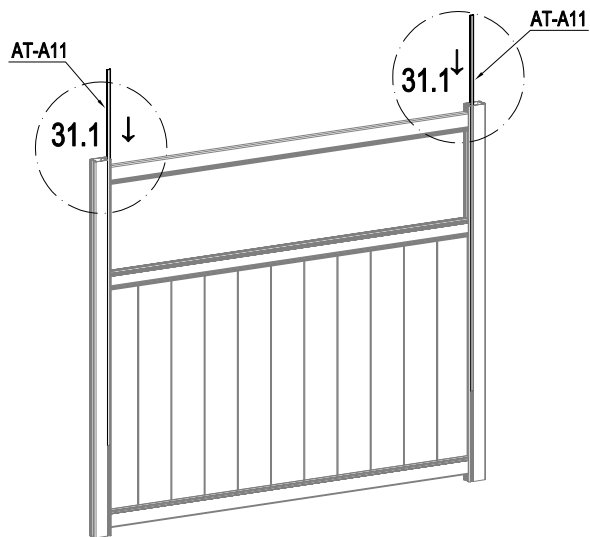
	DO-D1a	1
	Dr-28	2
	DO-28a	1
	DO-G31	6





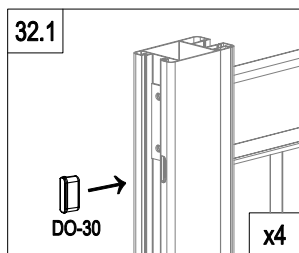
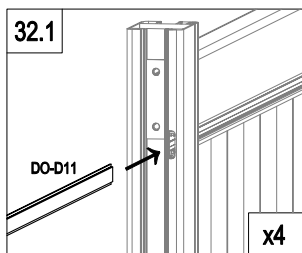
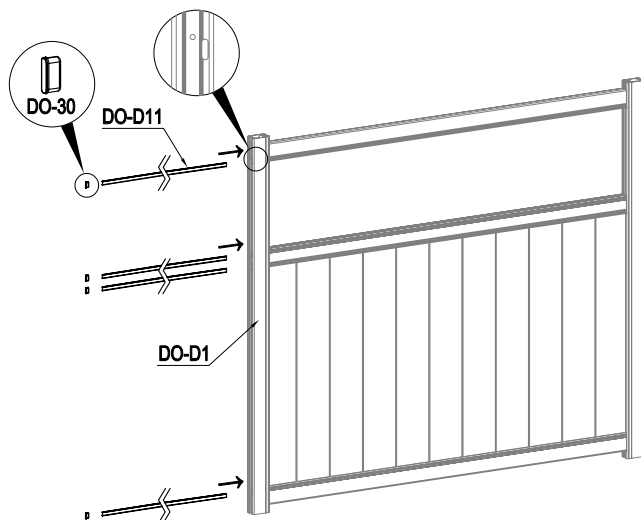



	AT-A11	2
---	--------	---

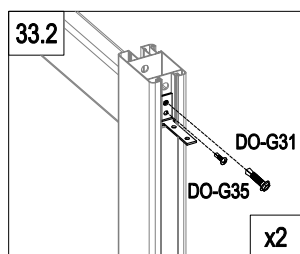
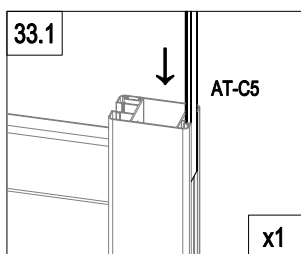
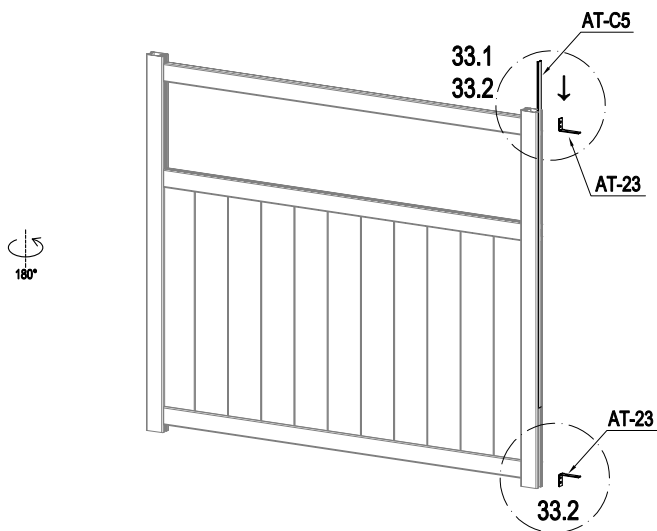





	DO-D11	4
	DO-30	4

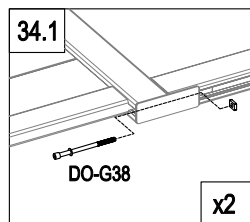
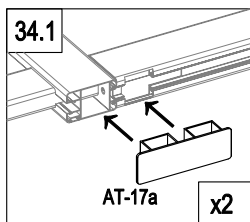
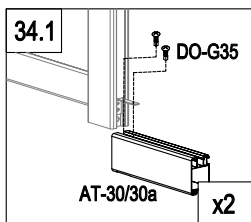
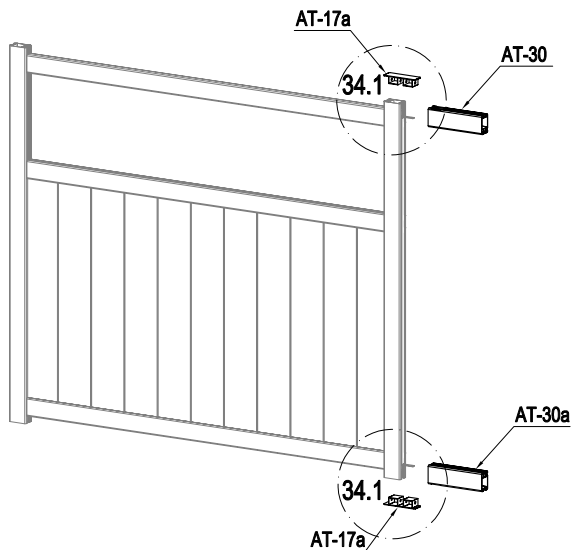

	AT-C5	1
	AT-23	2
	DO-G31	2
	DO-G35	2



	AT-30	1
	AT-30a	1
	AT-17a	2

	DO-G38	2
	DO-G35	4

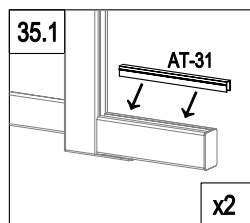
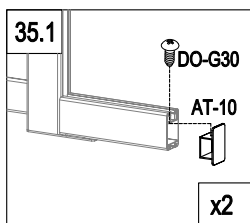
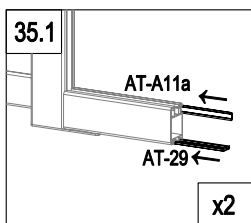
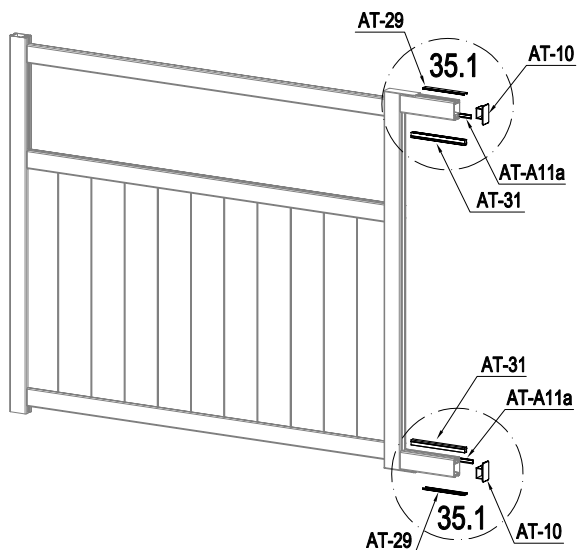

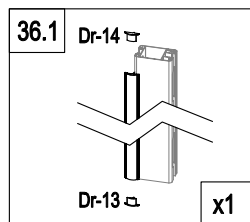
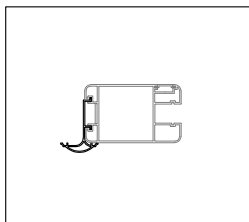
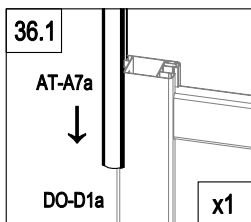
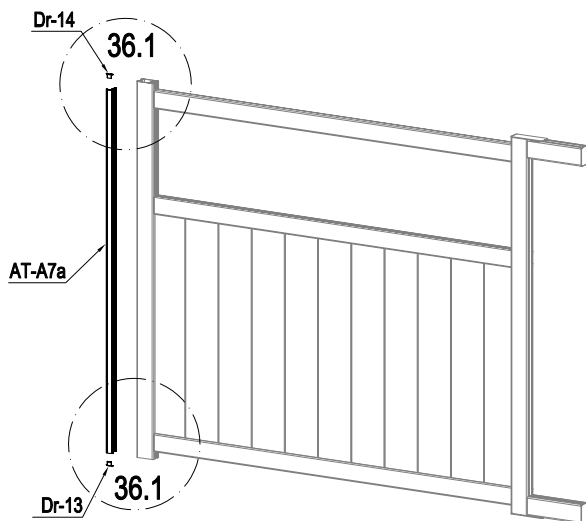

	AT-29	2
	AT-A11a	2
	AT-31	2

	AT-10	2
	DO-G30	2

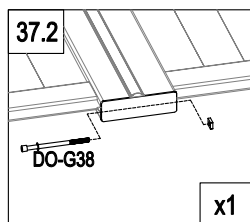
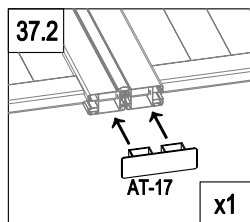
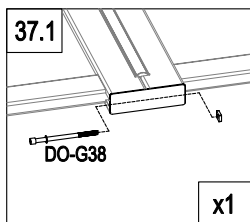
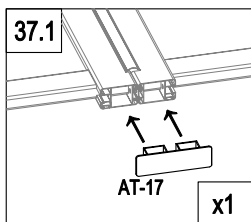
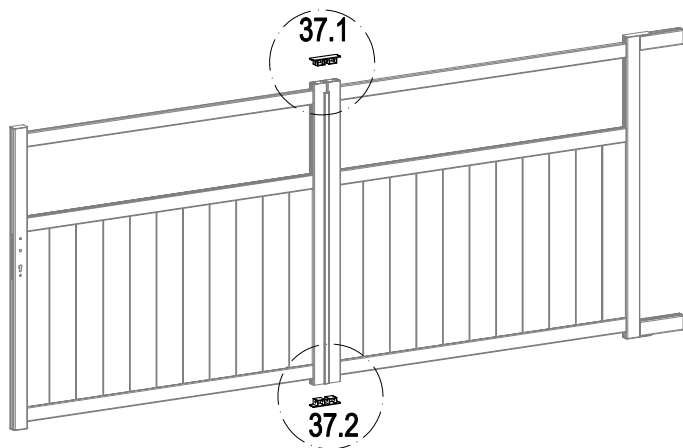

	AT-A7a	1
	Dr-13	1
	Dr-14	1



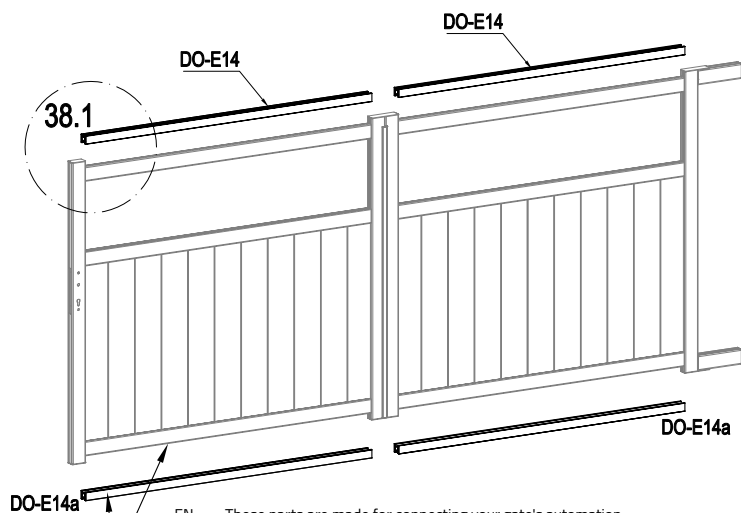

	AT-17	2
	DO-G38	2



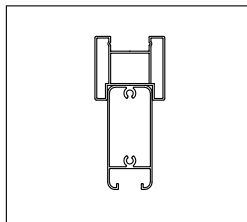
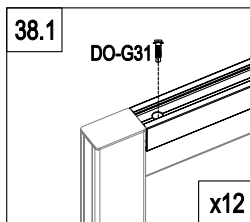
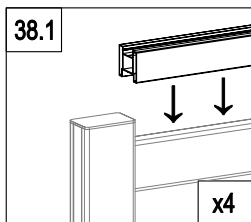

- EN: These parts are made for connecting your gate's automation
 FR: Ces pièces sont faites pour relier l'automatisation de votre portail
 DE: Diese Teile sind für den Anschluss der Automatisierung Ihres Tores vorgesehen
 ES: Estas piezas están hechas para conectar la automatización de su puerta
 PT: Estas peças são feitas para ligar a automatização do seu portão
 IT: Queste parti sono realizzate per collegare l'automazione del vostro cancello
 NL: Deze onderdelen zijn gemaakt voor het aansluiten van de automatisering van uw poort.
 PL: Te części są wykonane do podłączenia automatyki bramy.



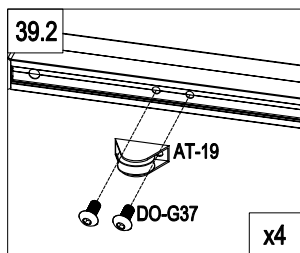
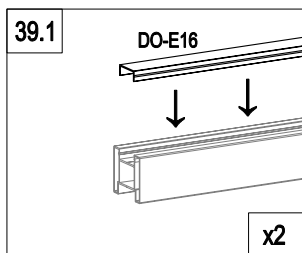
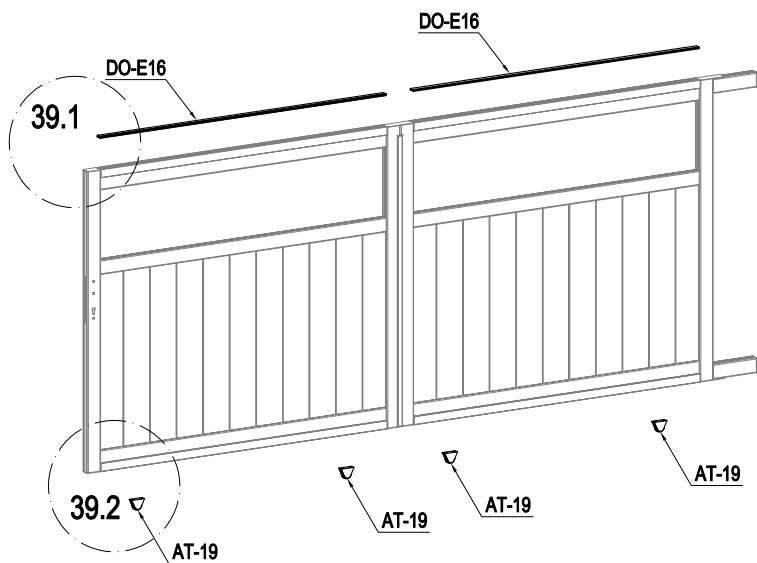

	DO-E14	2
	DO-E14a	2
	DO-G31	12

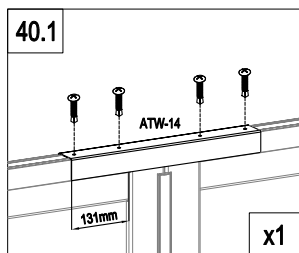
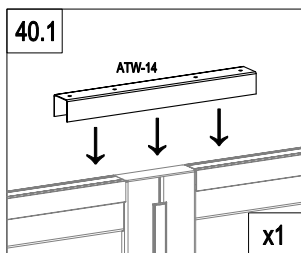
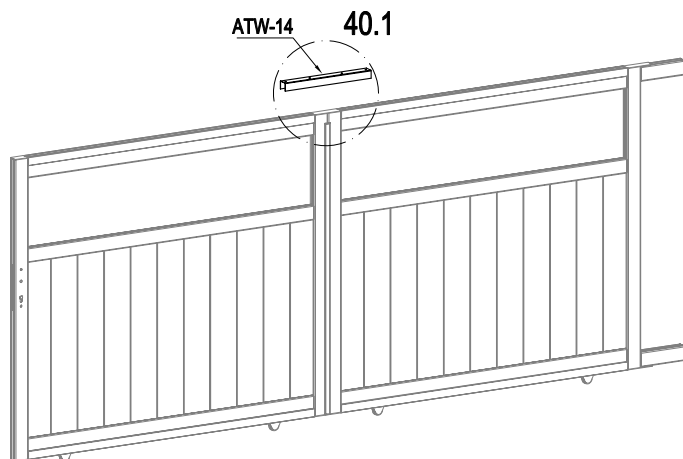

	DO-E16	2
	AT-19	4
	DO-G37	8



	ATW-14	1
	DO-G32	4

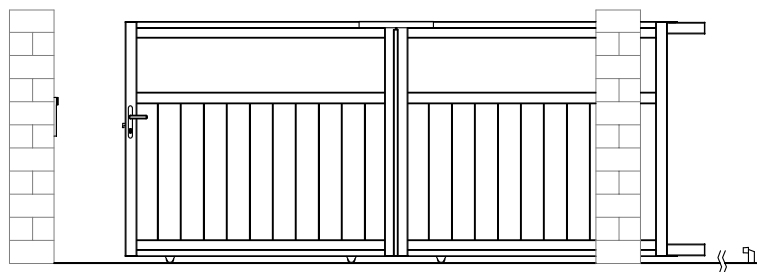



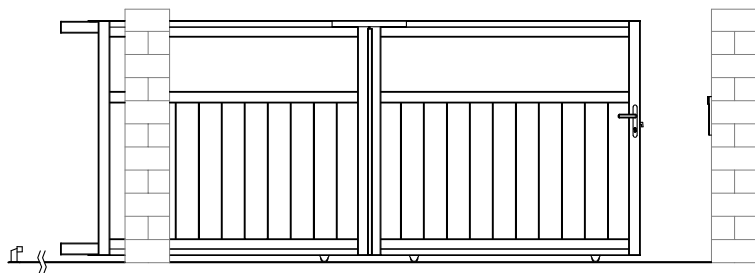

L : P 51~56

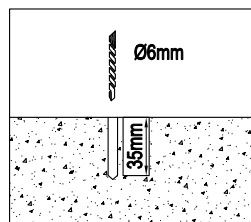
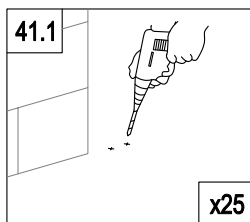
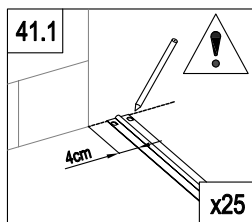
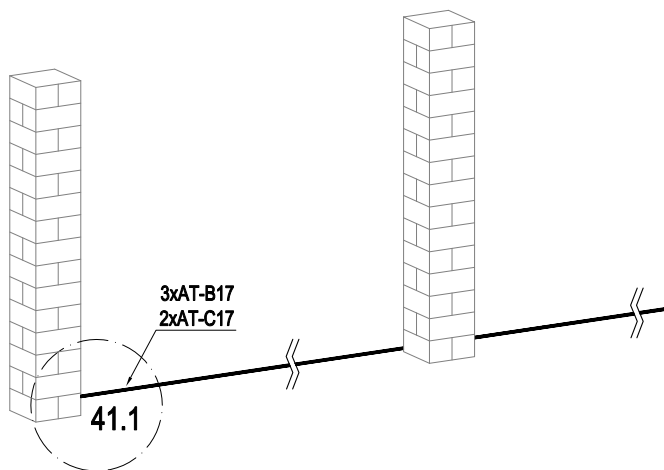

R : P 57~62

L



	AT-B17	3
	AT-C17	2
	DO-G34	50

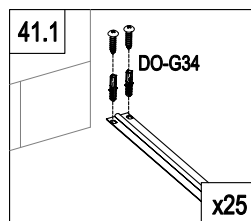

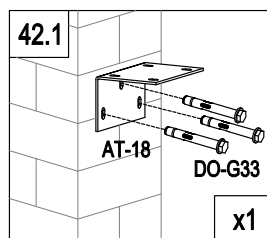
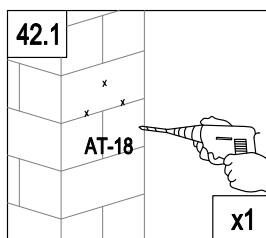
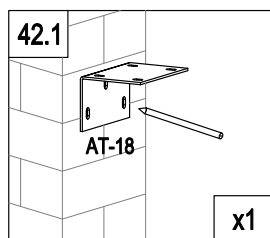
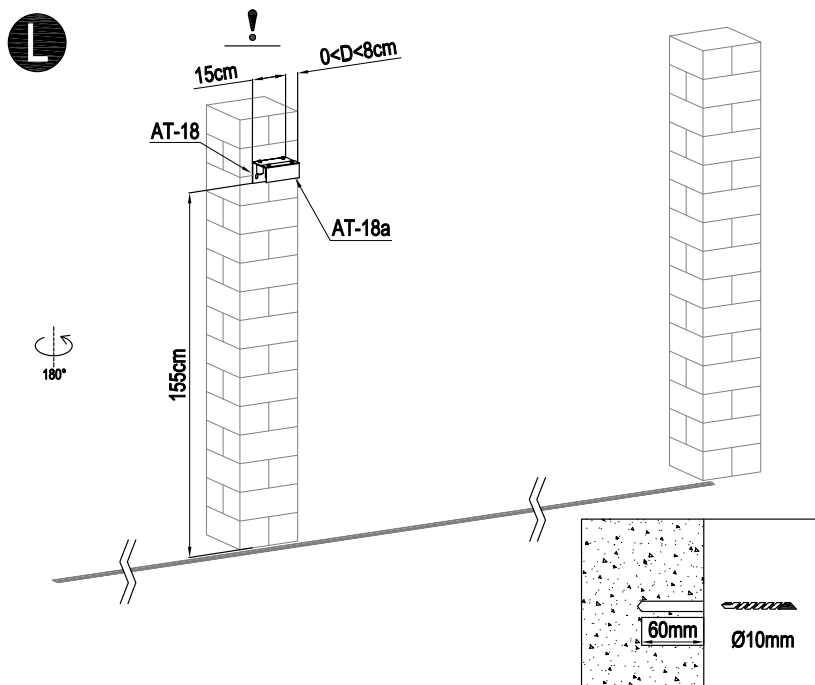

	AT-18	1
	AT-18a	1
	AT-20	4
	DO-G33	3

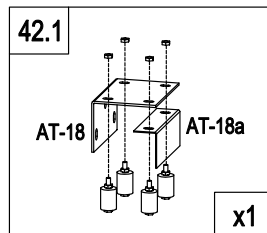
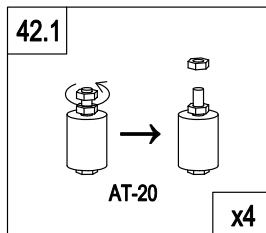

L

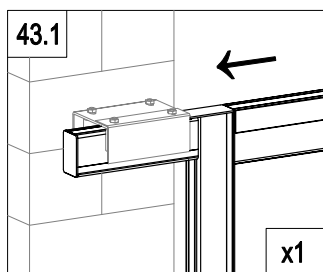
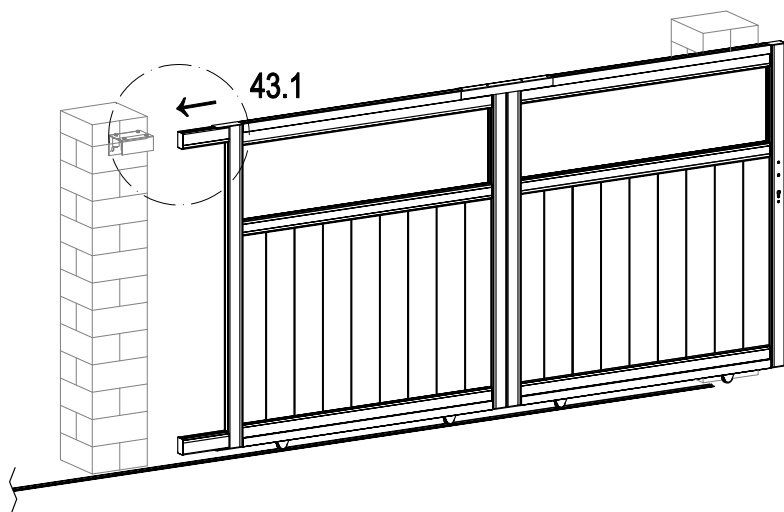

L

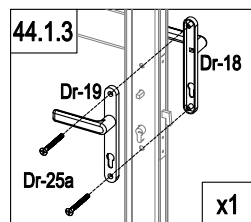
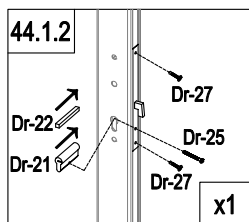
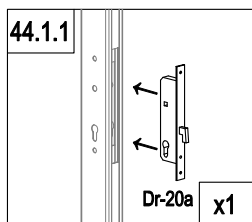
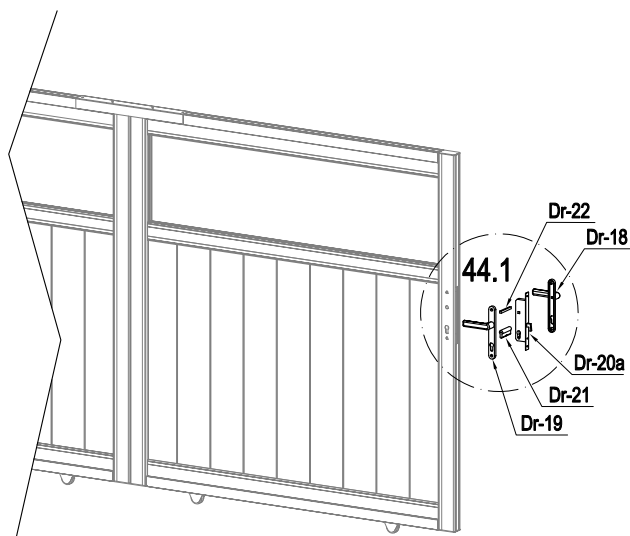

	Dr-20a	1
	Dr-21	1
	Dr-22	1
	Dr-25	1

	Dr-18	1
	Dr-19	1
	Dr-25a	2
	Dr-27	2

L

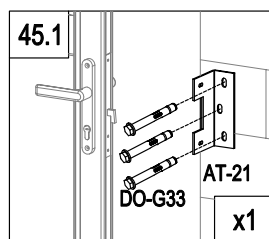
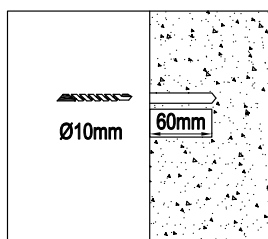
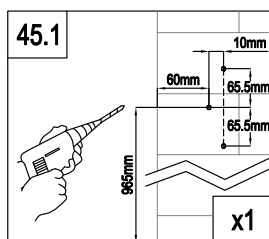
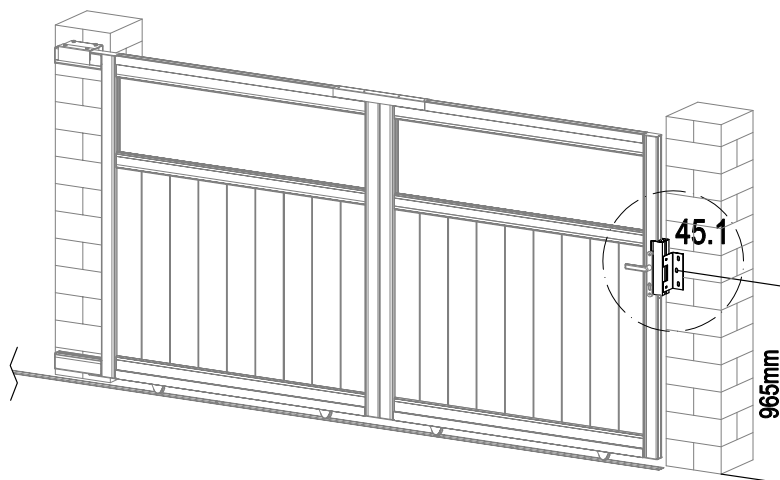

	AT-16	1
	AT-21	1
	DO-G36	2
	DO-G33	3
	AT-22J	3

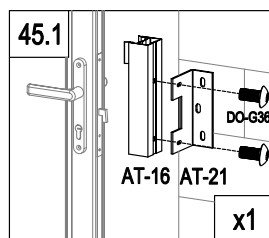
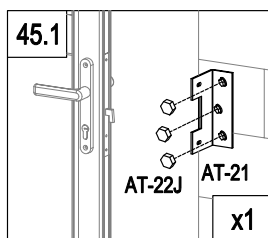

L

180°

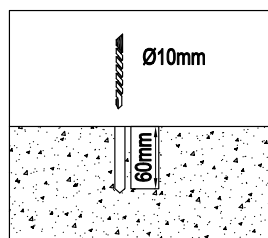
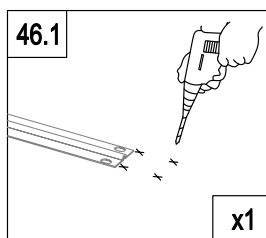
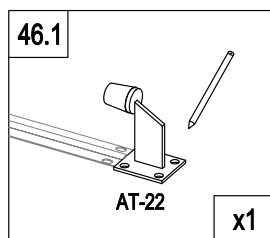
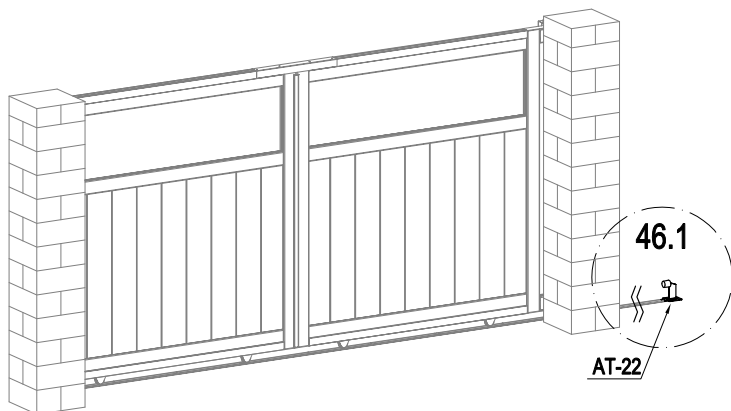

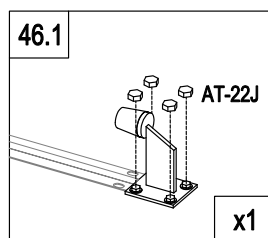
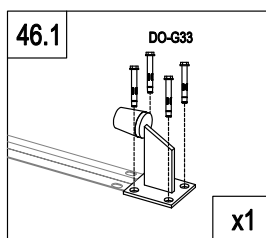

	AT-22	1
	DO-G33	4
	AT-22J	4

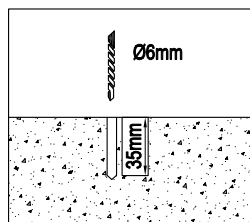
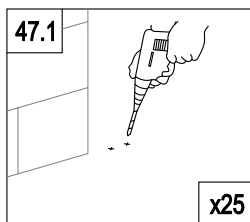
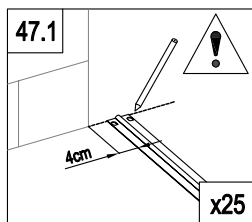
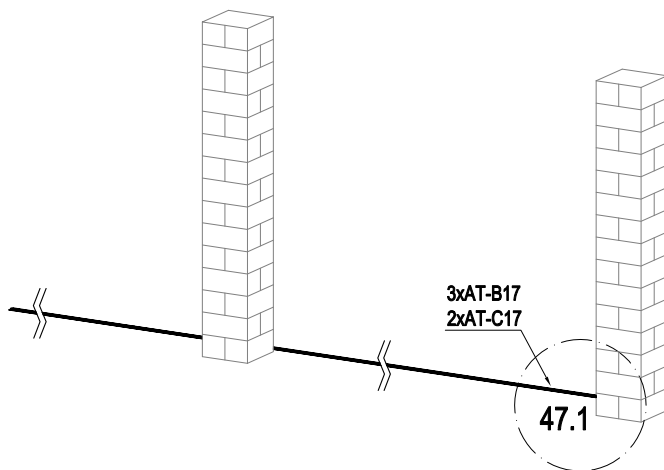

R



	AT-B17	3
	AT-C17	2
	DO-G34	50

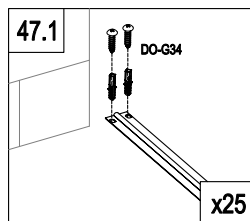

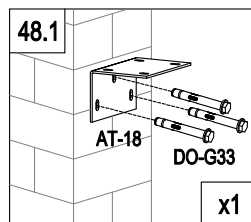
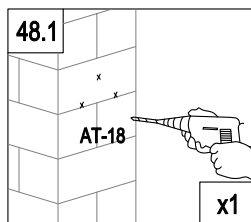
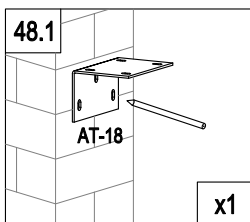
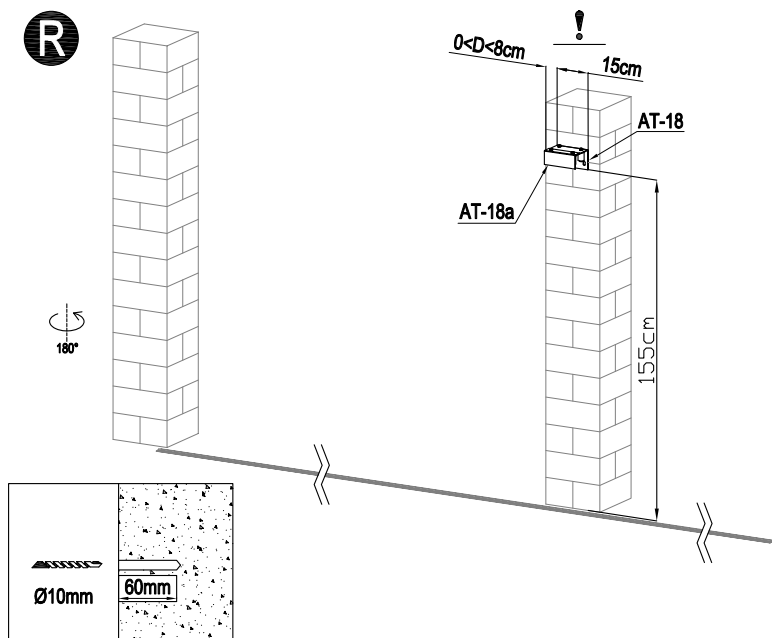

	AT-18	1
	AT-18a	1
	AT-20	4
	DO-G33	3

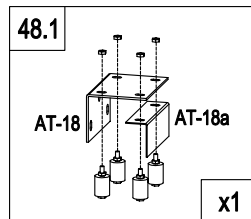
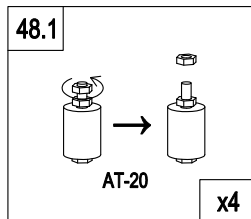

R

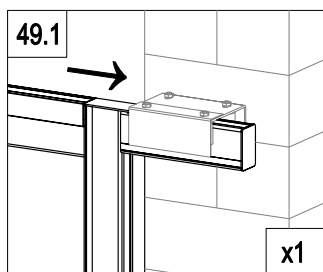
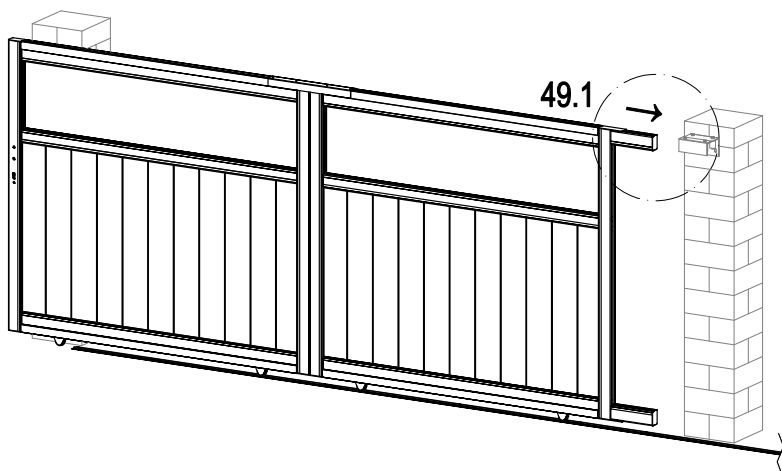

R

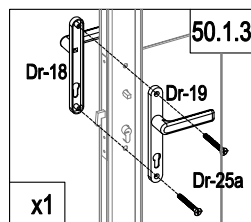
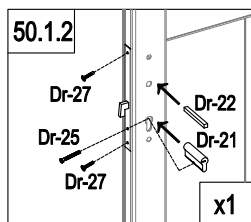
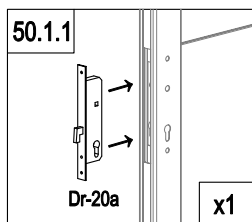
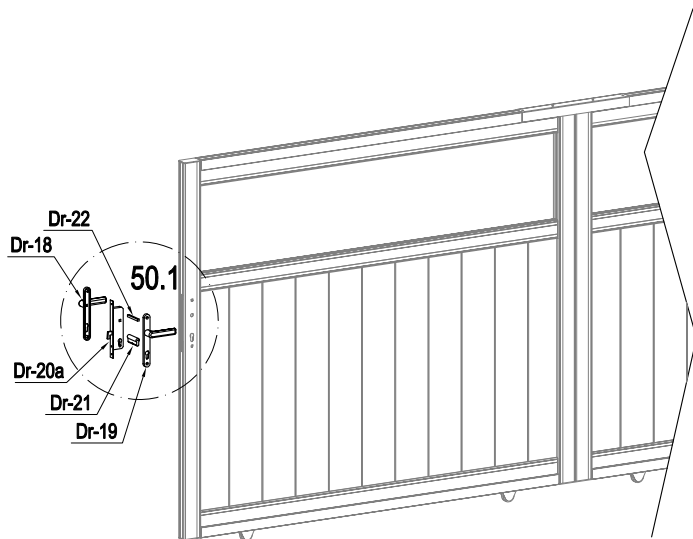

	Dr-20a	1
	Dr-21	1
	Dr-22	1
	Dr-25	1

	Dr-18	1
	Dr-19	1
	Dr-25a	2
	Dr-27	2

R

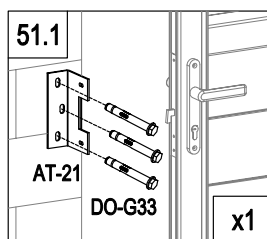
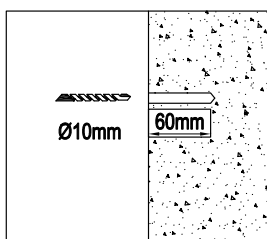
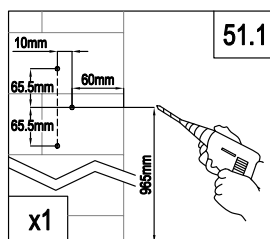
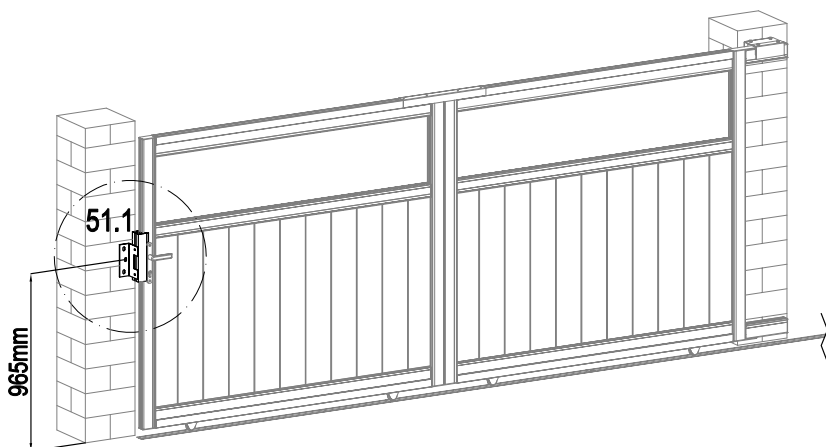

	AT-16	1
	AT-21	1
	DO-G36	2
	DO-G33	3
	AT-22J	3

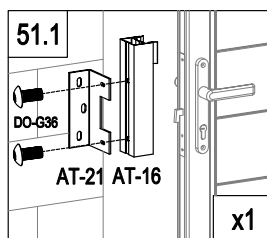
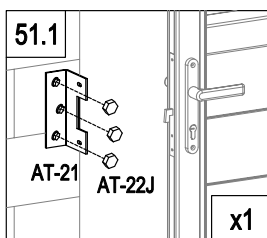

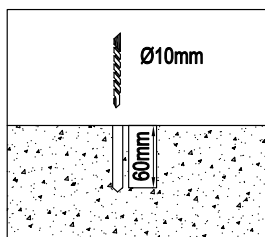
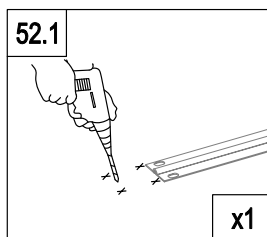
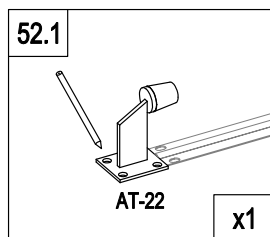
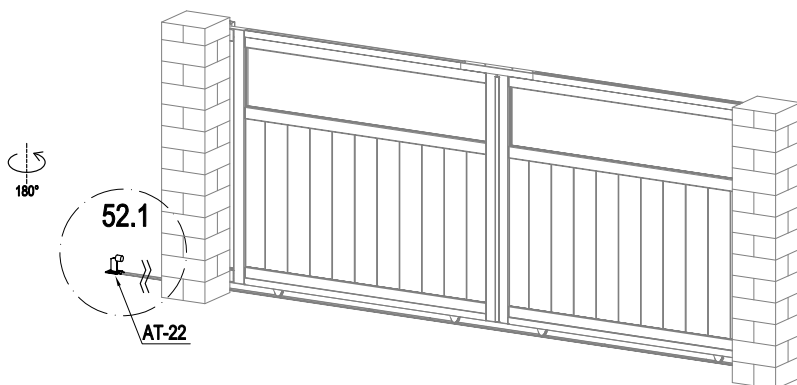

	AT-22	1
	DO-G33	4
	AT-22J	4

