

CASANOVO

Do 400B160

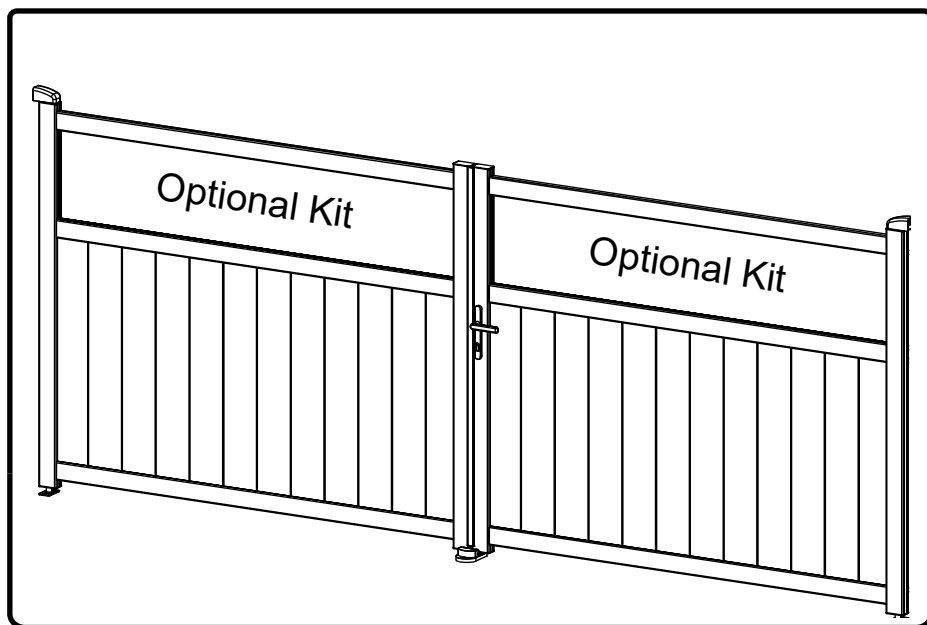

INSTRUCTION MANUAL / NOTICE DE MONTAGE / MONTAGEANLEITUNG / MANUAL DE MONTAJE / MANUAL DE MONTAGEM / MANUALE DI MONTAGGIO /
MONTAGEHANDLEIDING / INSTRUKCJA MONTAŻU / KÄYTTÖOHJEET / BRUKSANVISNING / BRUGSANVISNING / INSTRUCȚIUNI DE ASAMBLARE /
NAVODILA ZA SESTAVLJANJE / NÁVOD NA MONTÁŽ / ÖSSZESZERELÉSI ÚTMUTATÓ / NÁVOD K MONTÁŽI / UPUTE ZA INSTALACIJU /
ΟΔΗΓΙΕΣ ΣΥΝΑΡΜΟΛΟΓΗΣΗΣ / SURINKIMO INSTRUKCIJOS / MONTĀŽAS INSTRUKCIJAS

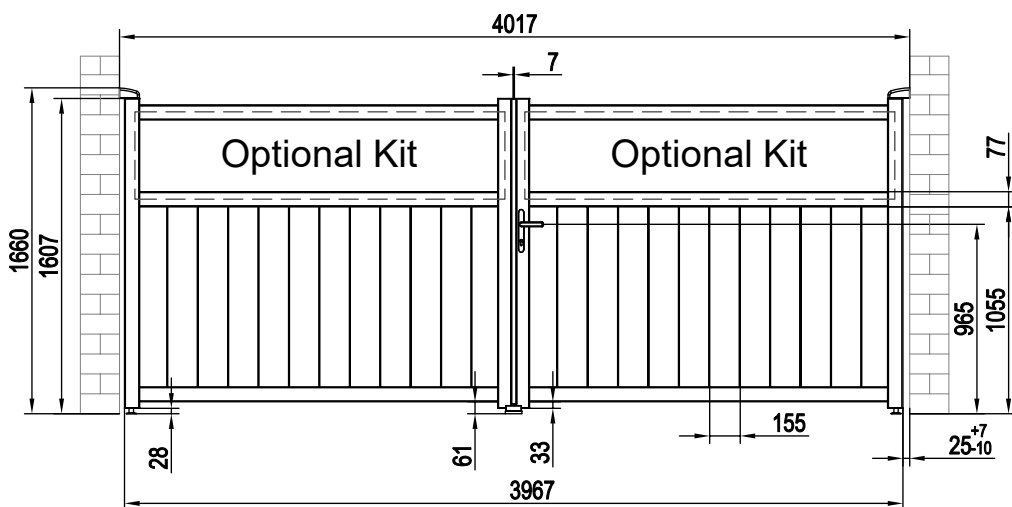

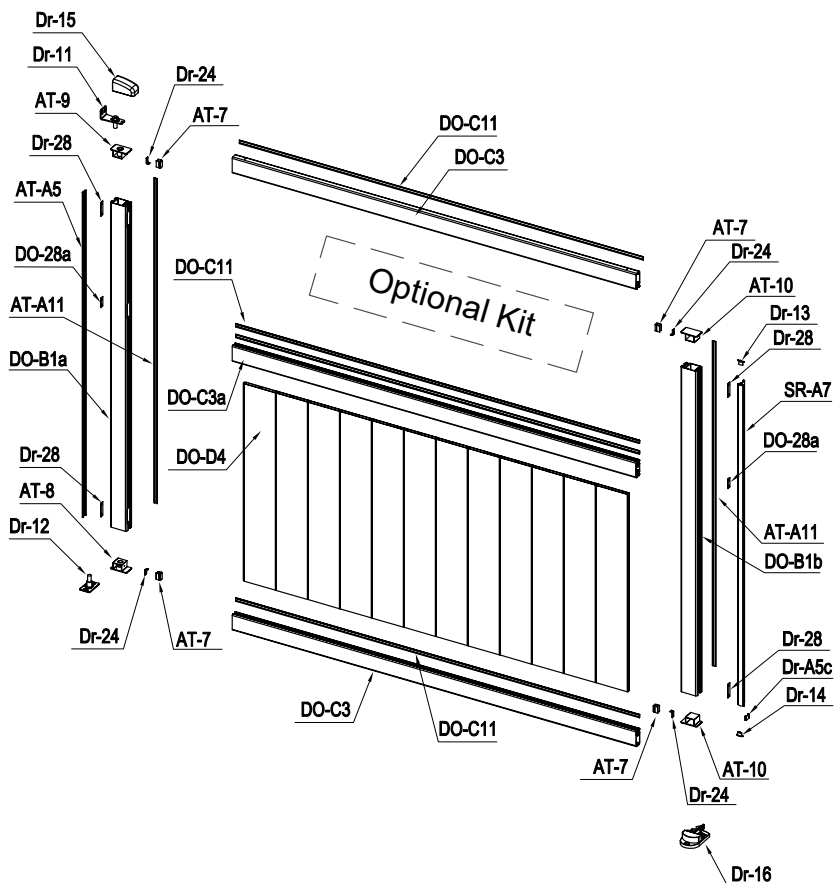
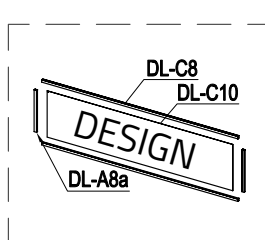
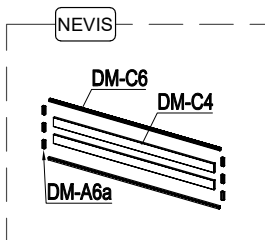
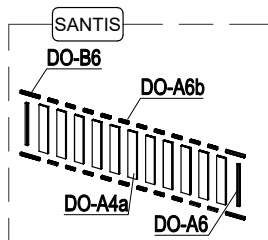

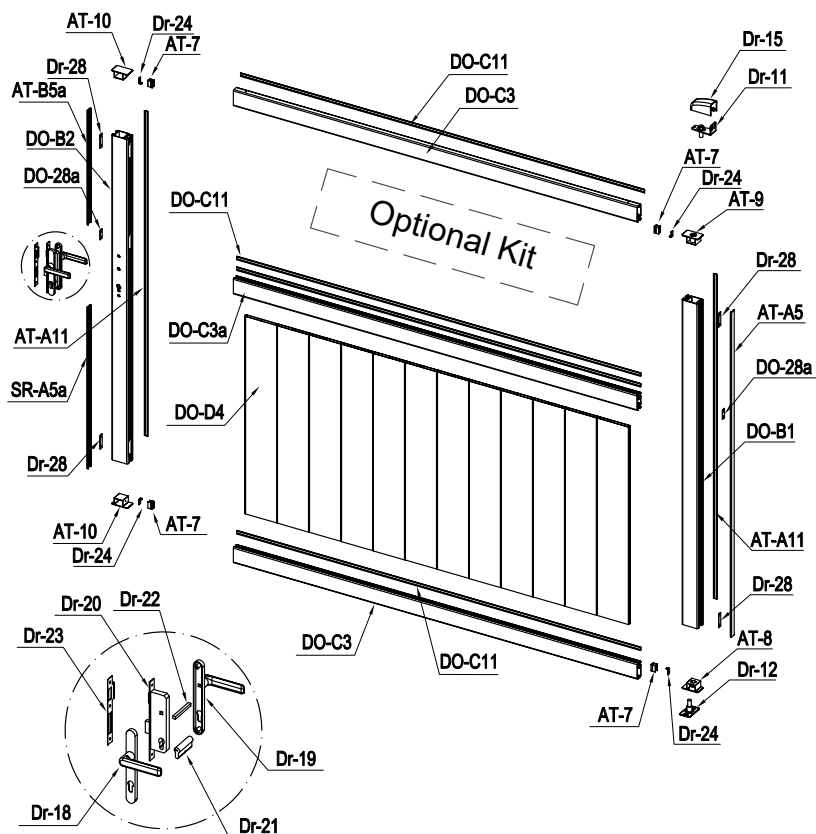
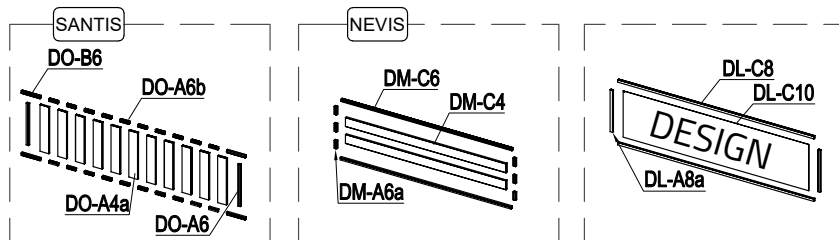













PARTS LIST

IMAGE	NO.	L.(mm)	QTY	IMAGE	NO.	L.(mm)	QTY
	DO-B1	1573	1		Dr-20		1
	DO-B1a	1573	1		Dr-21		1
	DO-B1b	1573	1		Dr-22		1
	DO-B2	1573	1		Dr-23		1
	DO-C3	1957	4		Dr-25		1
	DO-C3a	1957	2		Dr-25a		2
	DO-D4	779	24		Dr-26		3
	AT-A5	1573	2		Dr-27		2
	AT-B5a	550.5	1		Dr-24		8
	SR-A5a	782	1		Dr-28		8
	Dr-A5c	19.5	1		DO-28a		4
	AT-A11	1573	4		DO-E30	ST4x10	8
	DO-C11	1957	8		DO-E31	ST5.5x38	24
	AT-7	29.5	8		DO-E32	ST4.8x38	12
	SR-A7	1553	1		DO-E33	M8x60	12
	DO-C15	1955	2		DO-E34	ST6x40	3
	AT-8		2		DO-E35	ST4.2x13	56
	AT-9		2		DO-E36	Ø6	3
	AT-10		4				
	Dr-11		2				
	Dr-12		2				
	Dr-13		1				
	Dr-14		1				
	Dr-15		2				
	Dr-16		1				
	Dr-17		2				
	Dr-31		4				
	DO-30		8				
	Dr-18		1				
	Dr-19		1				

PARTS LIST (Optional Kit)

	IMAGE	NO.	L.(mm)	QTY
		DO-A4a	406	22
		DO-A6	364	4
		DO-B6	163	8
		DO-A6b	77.5	40
	DO-35		44	

	IMAGE	NO.	L.(mm)	QTY
		DM-C4	1865	4
		DM-C6	1955	4
		DM-A6a	69	12
	DO-32		8	

	IMAGE	NO.	L.(mm)	QTY
		DL-C8	1955	4
		DL-A8a	364	4
		DL-C10	1862	2
		DO-32		8
	DO-35		24	

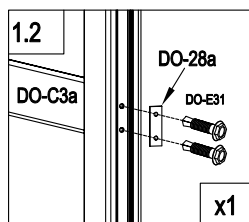
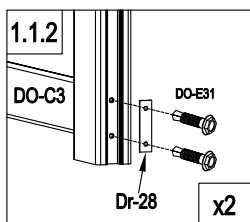
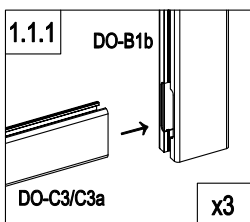
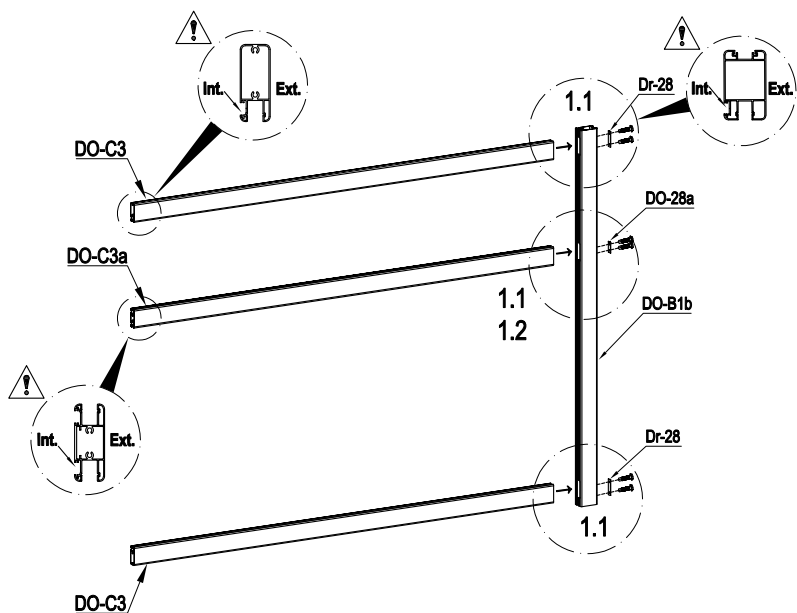

	DO-B1b	1
	DO-C3	2
	DO-C3a	1

	Dr-28	2
	DO-28a	1
	DO-E31	6

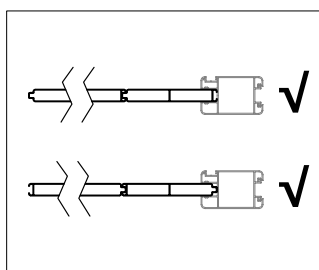
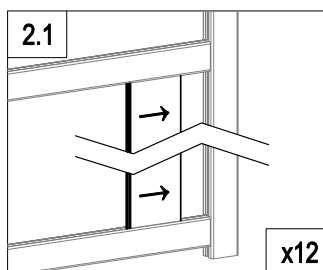
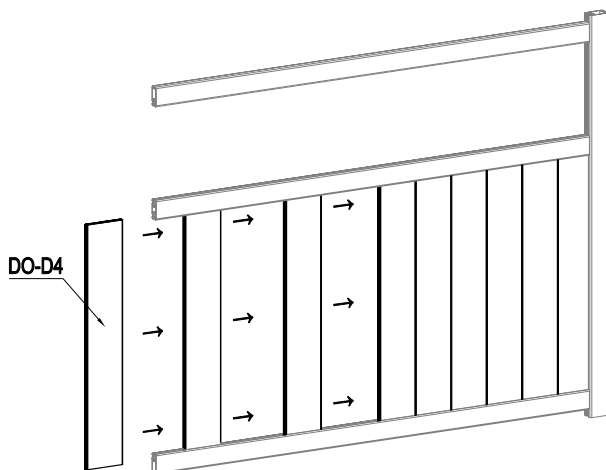

	DO-D4	12
---	-------	----

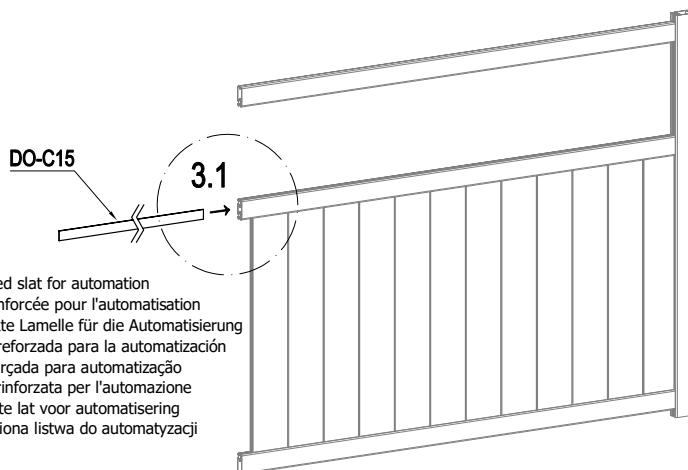

- EN: reinforced slat for automation
 FR: lame renforcée pour l'automatisation
 DE: verstärkte Lamelle für die Automatisierung
 ES: Lámina reforzada para la automatización
 PT: ripa reforçada para automatização
 IT: lamella rinforzata per l'automazione
 NL: versterkte lat voor automatisering
 PL: wzmocniona listwa do automatyzacji

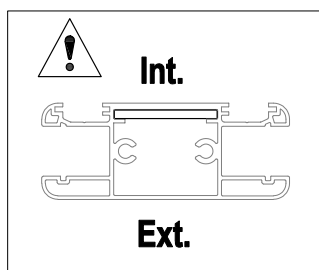
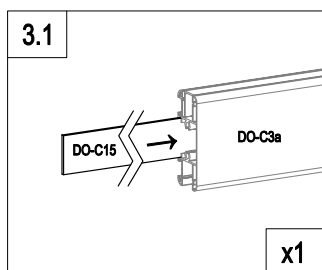

	DO-C15	1
---	--------	---

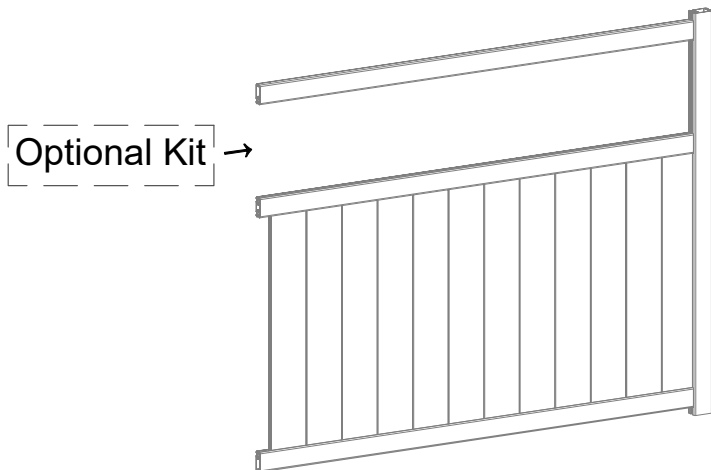

P 11~14



P 15~18



P 19~21

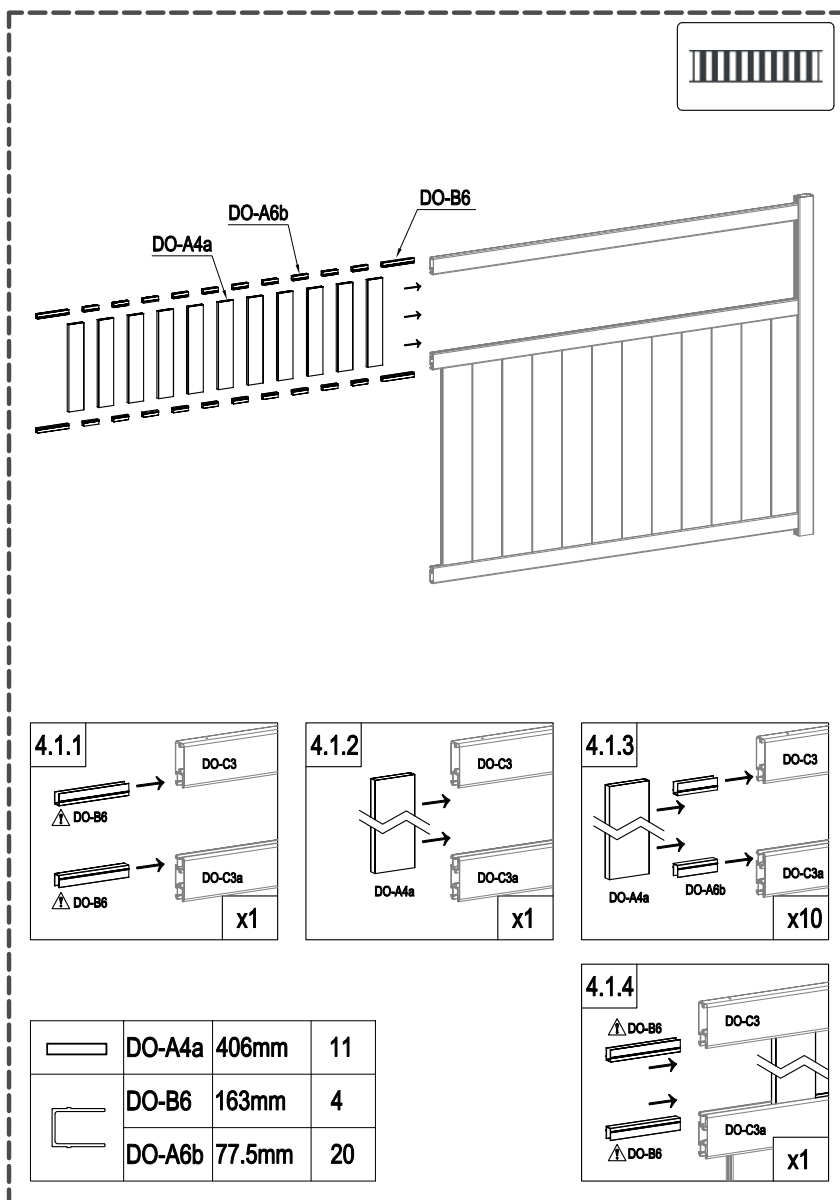

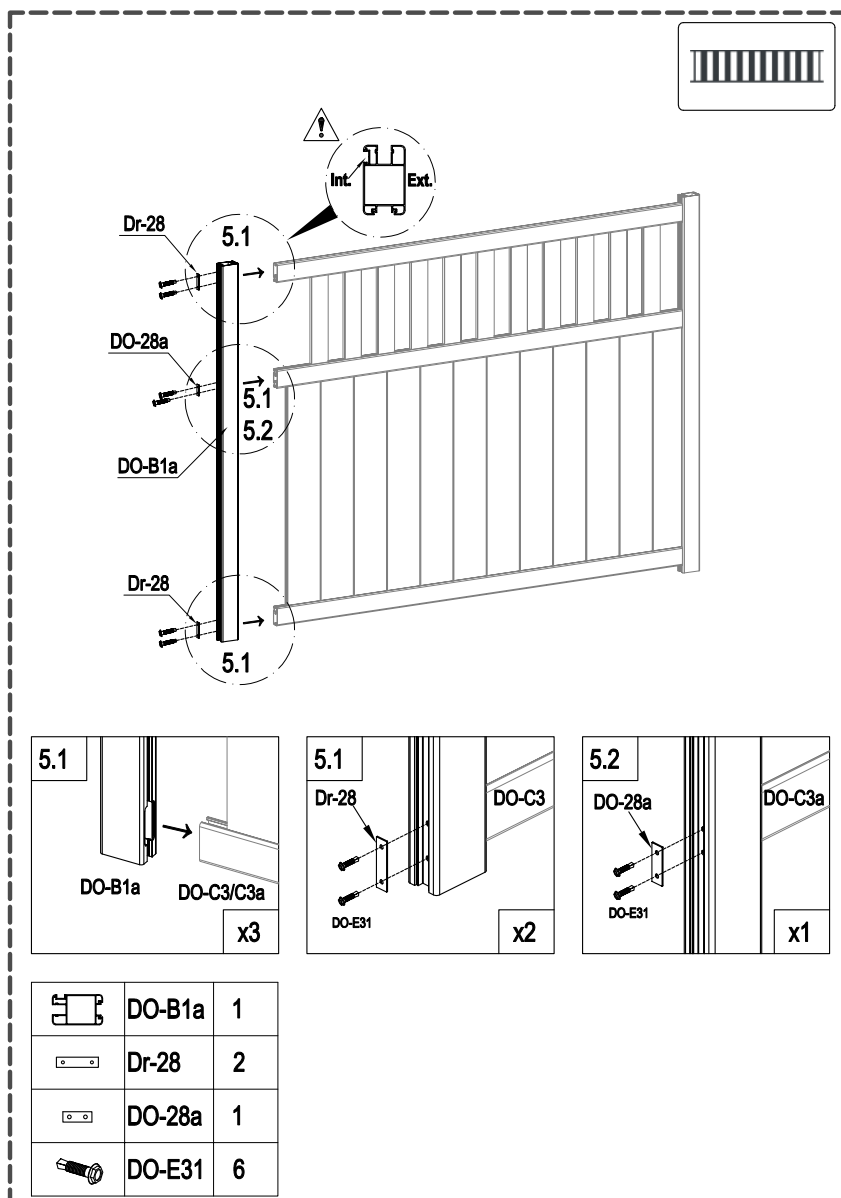

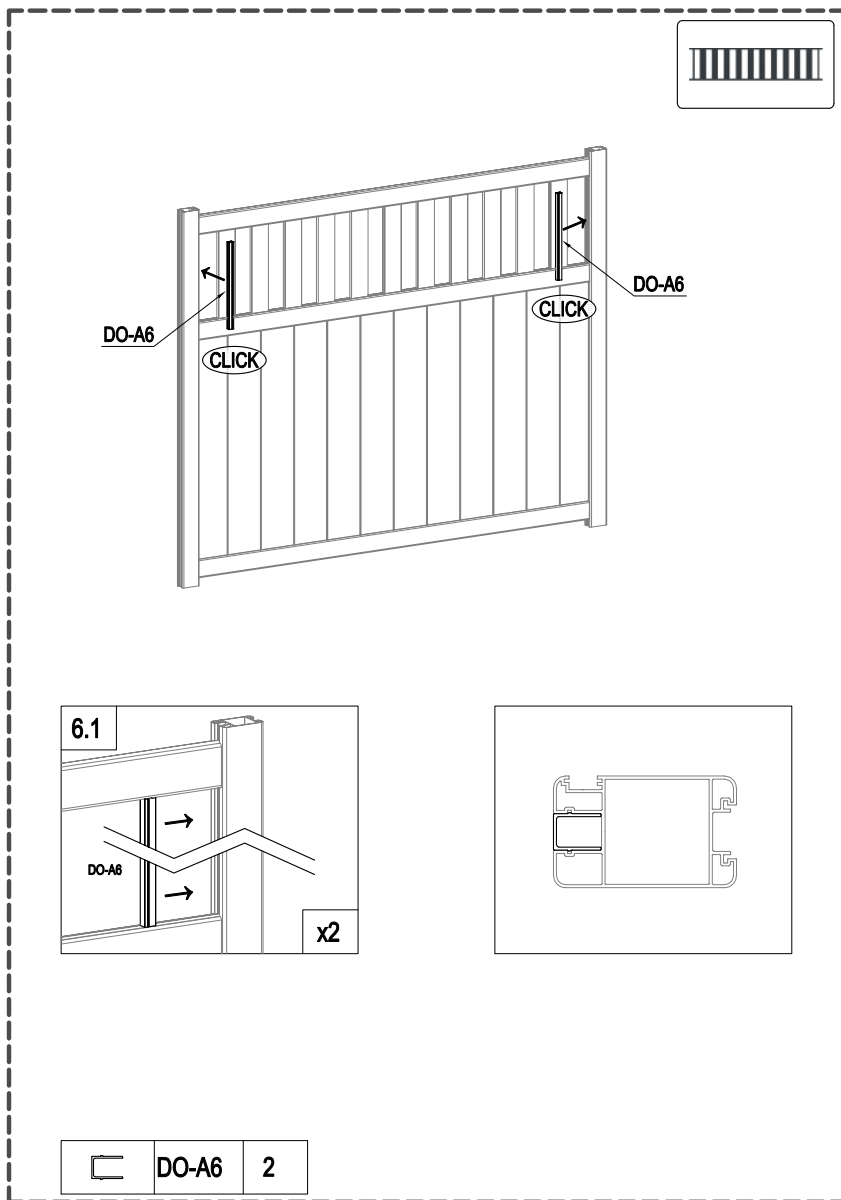

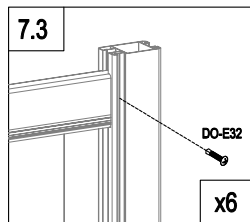
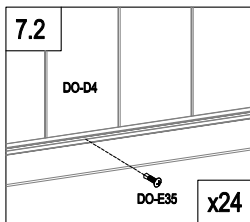
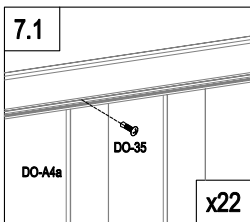
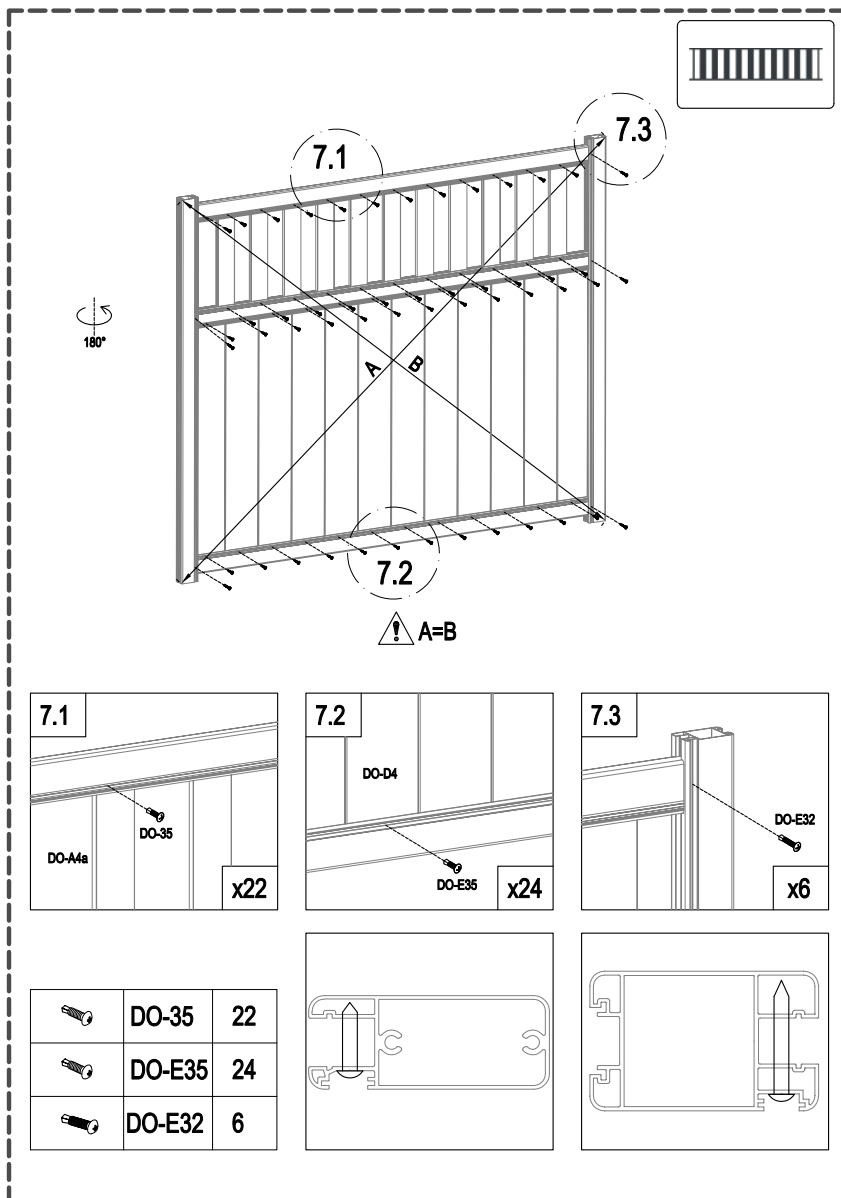

	DO-35	22
	DO-E35	24
	DO-E32	6

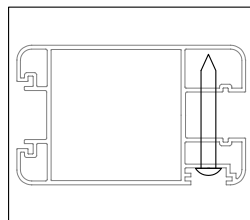
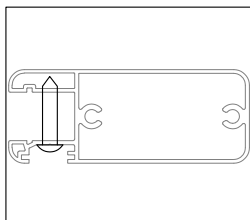

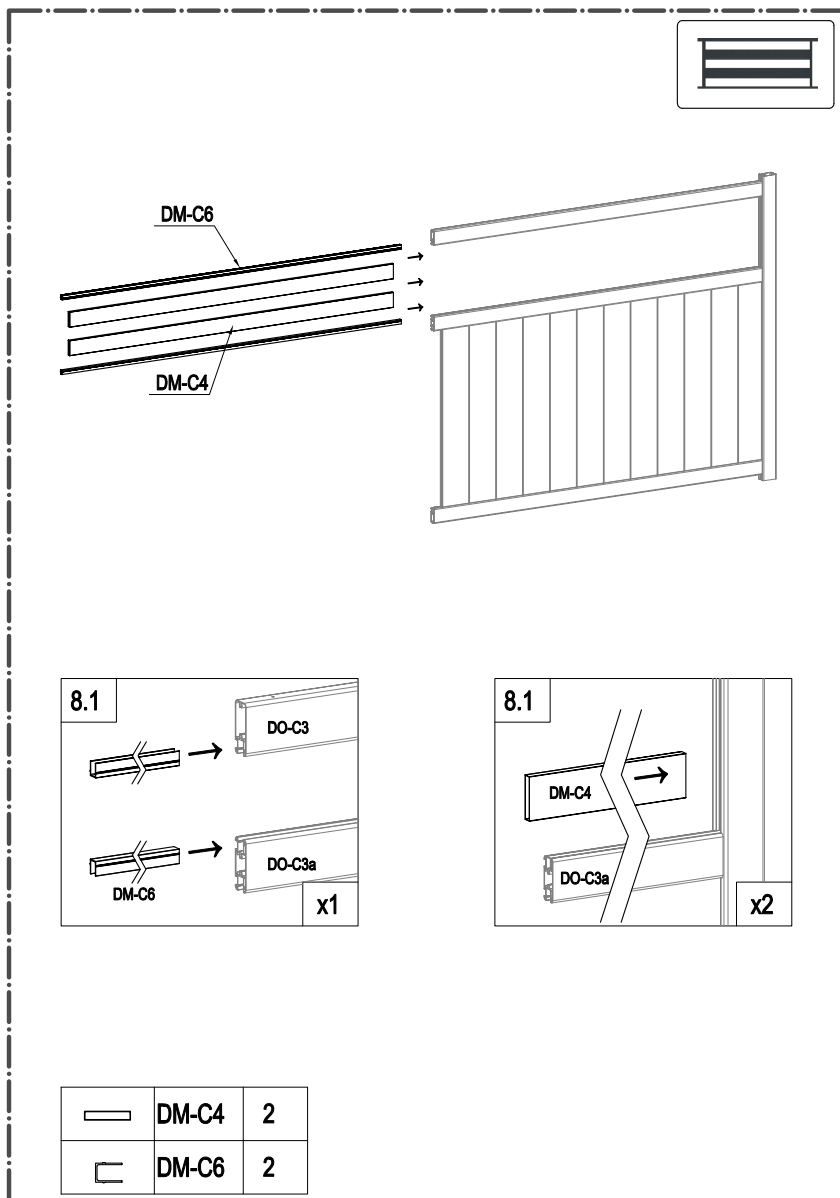

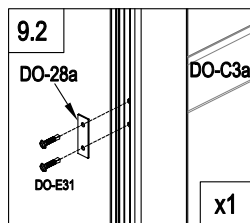
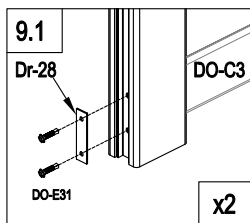
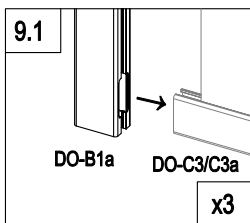
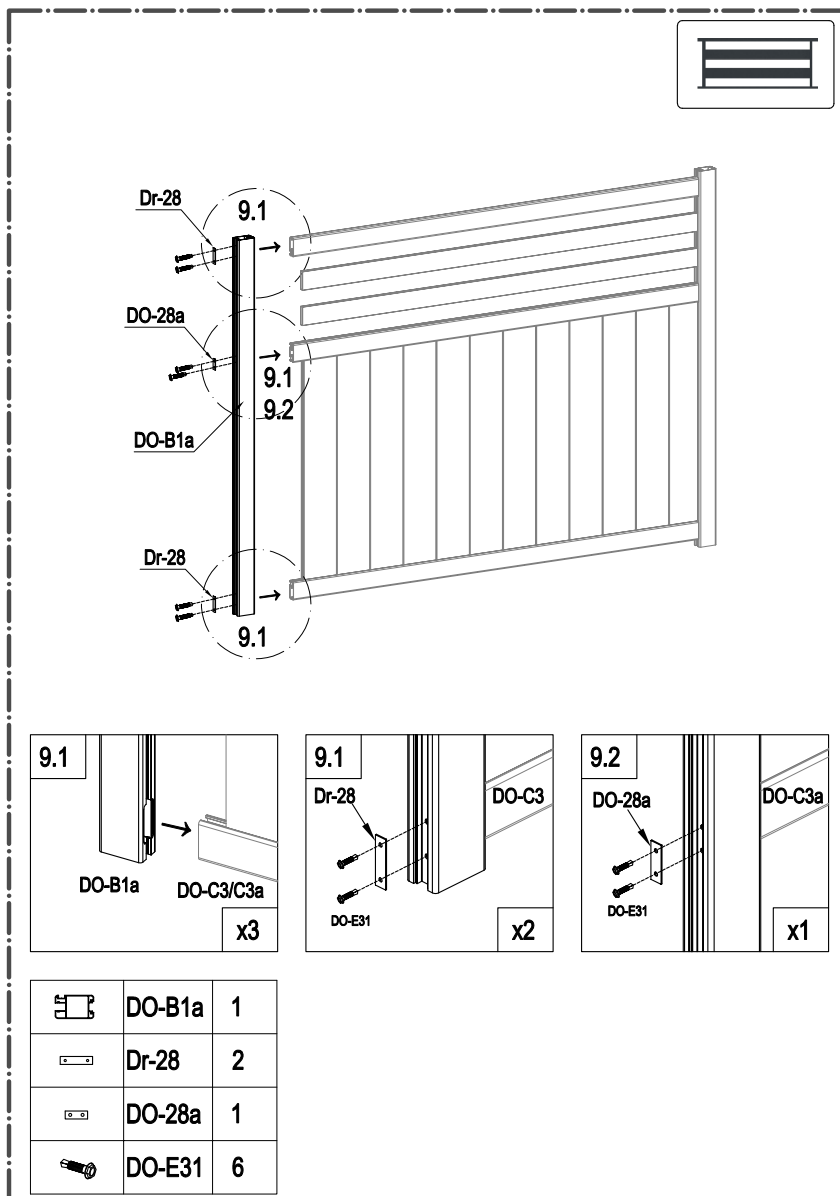

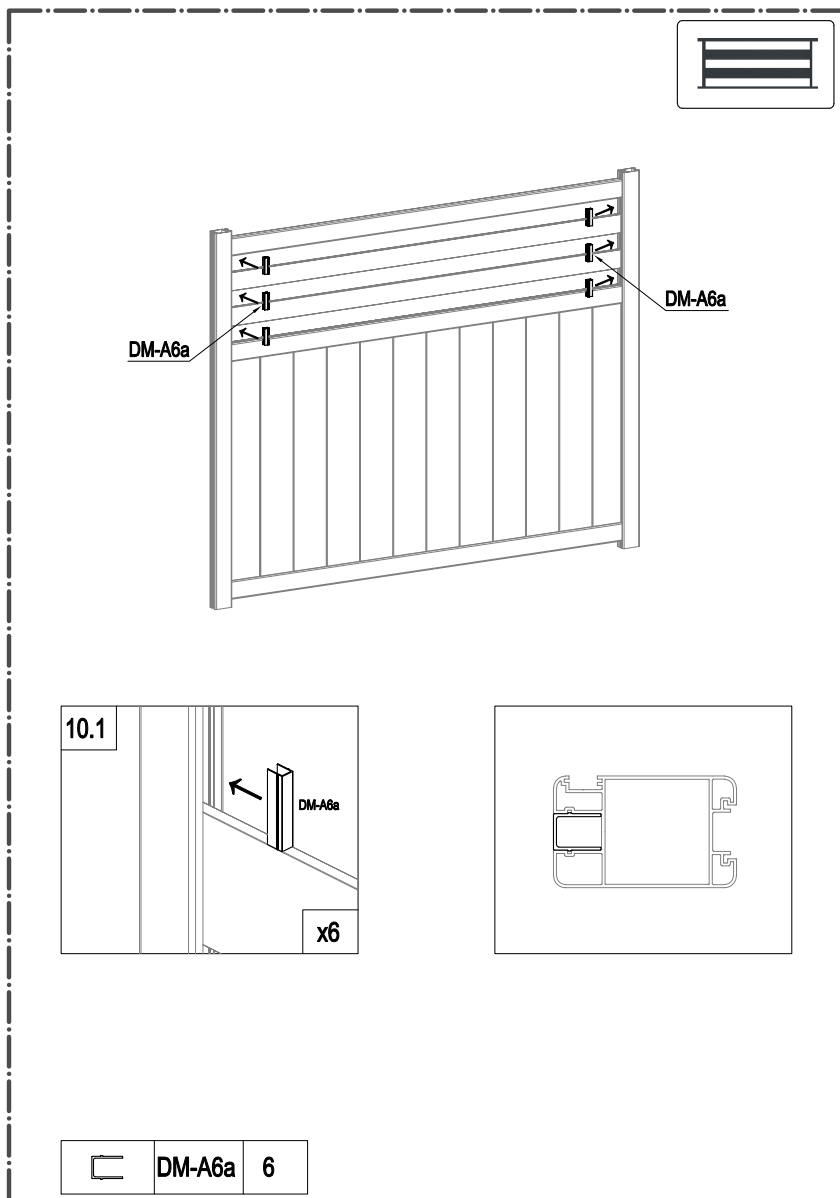

	DO-B1a	1
	Dr-28	2
	DO-28a	1
	DO-E31	6

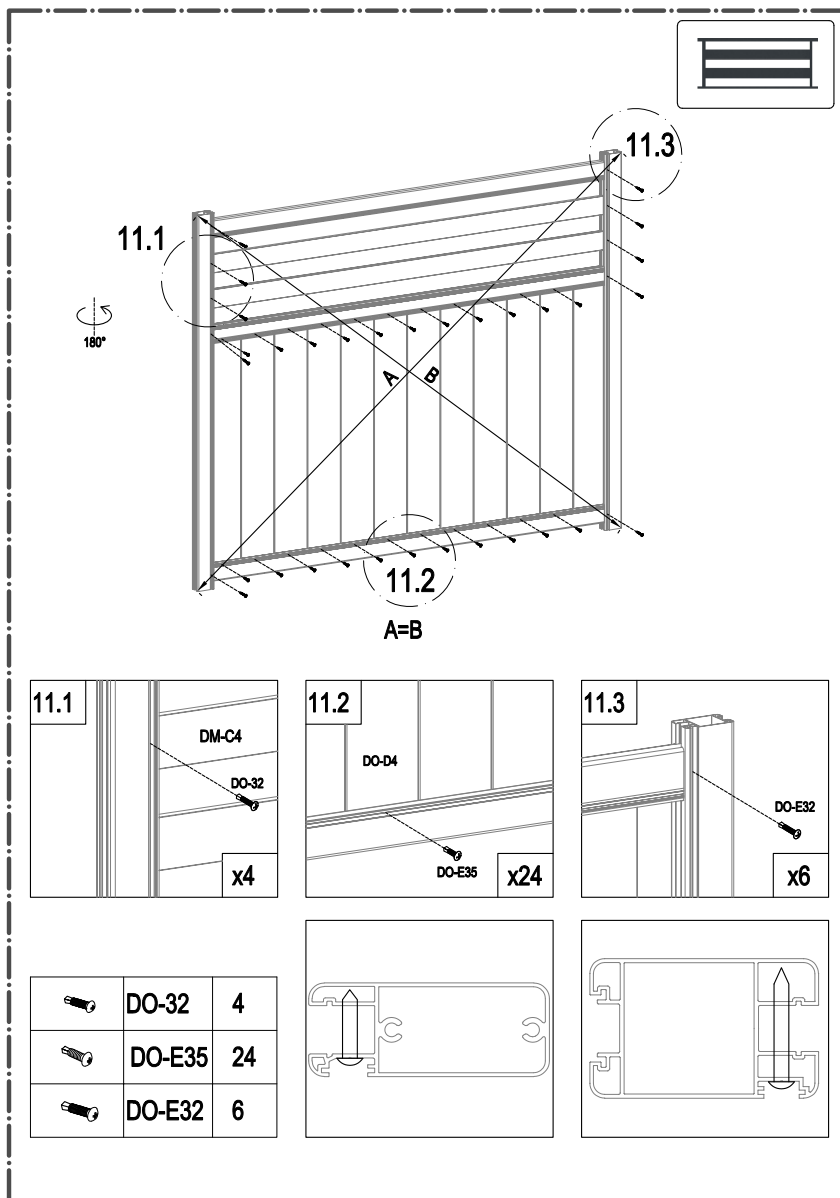

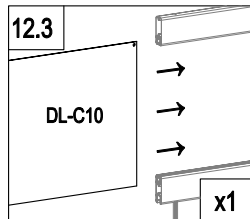
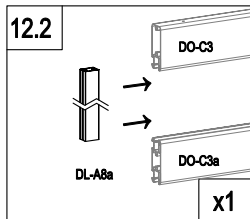
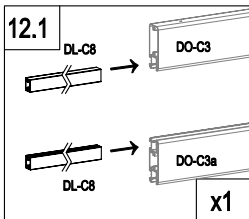
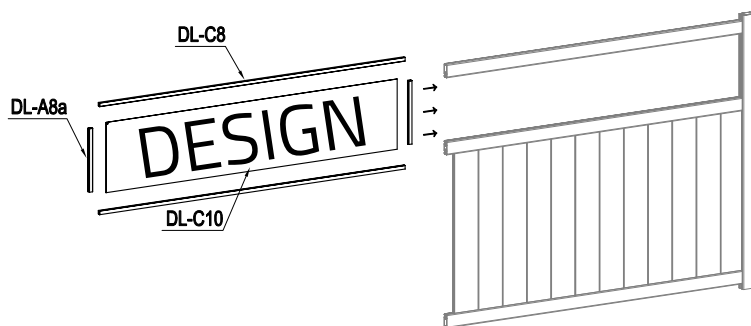

DESIGN





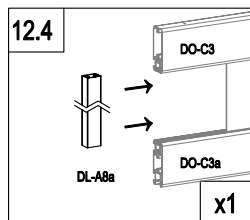

DESIGN	DL-C10	1
	DL-C8	2
	DL-A8a	2

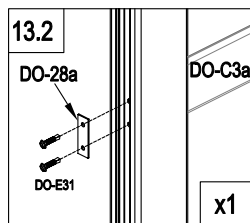
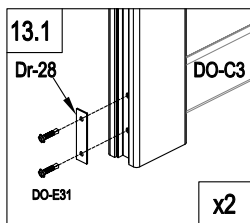
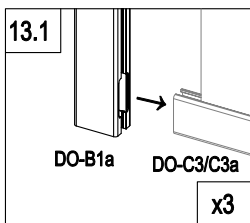
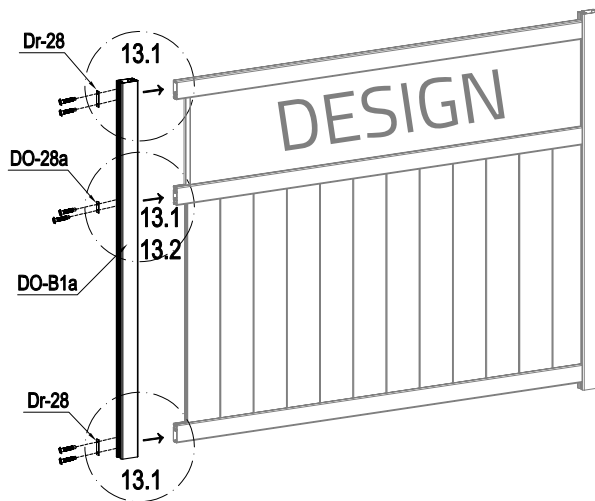

DESIGN



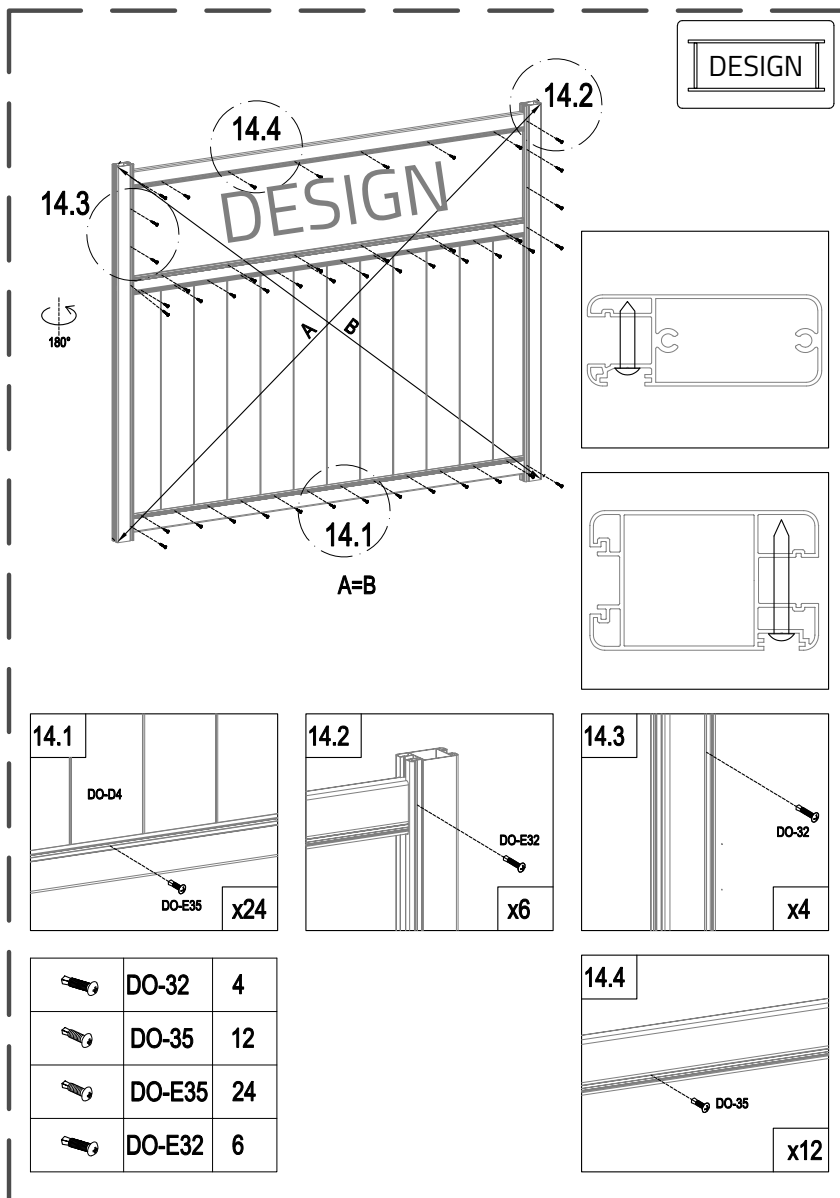

	DO-B1a	1
	Dr-28	2
	DO-28a	1
	DO-E31	6

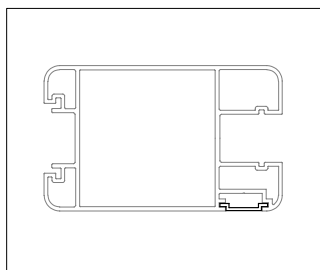
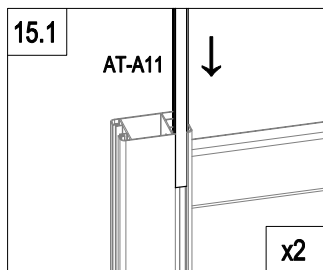
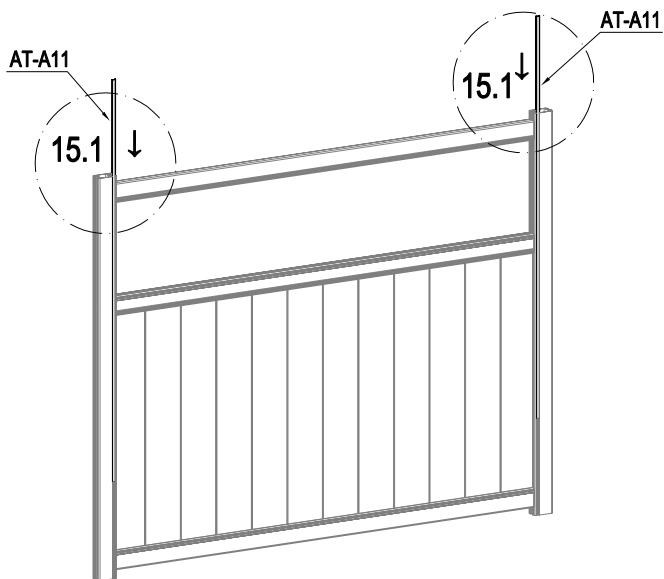



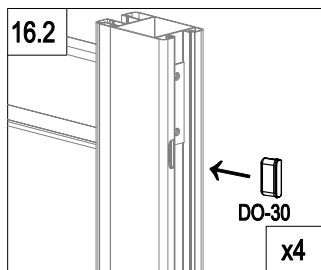
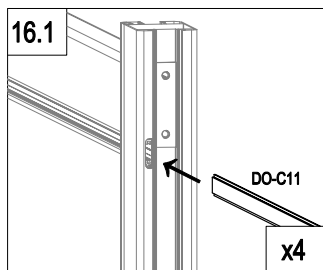
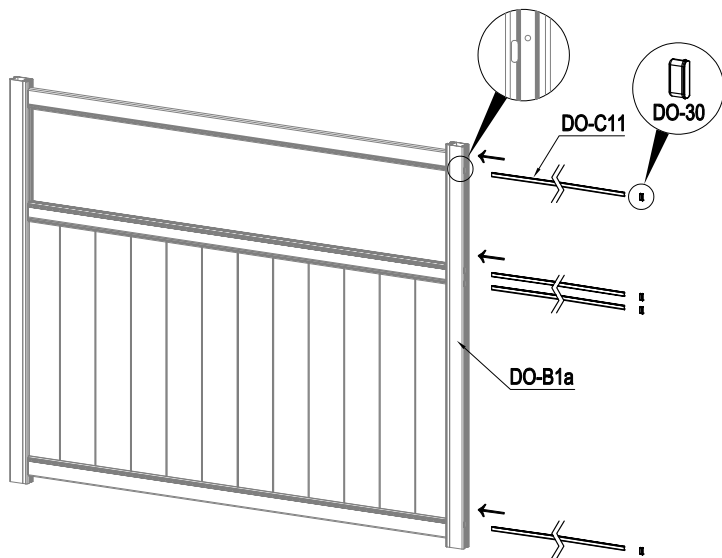

	AT-A11	2
---	--------	---

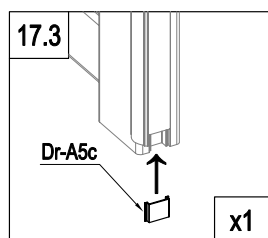
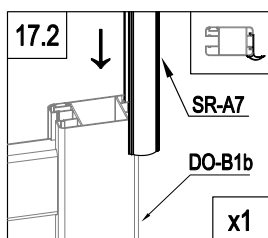
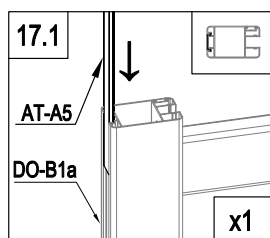
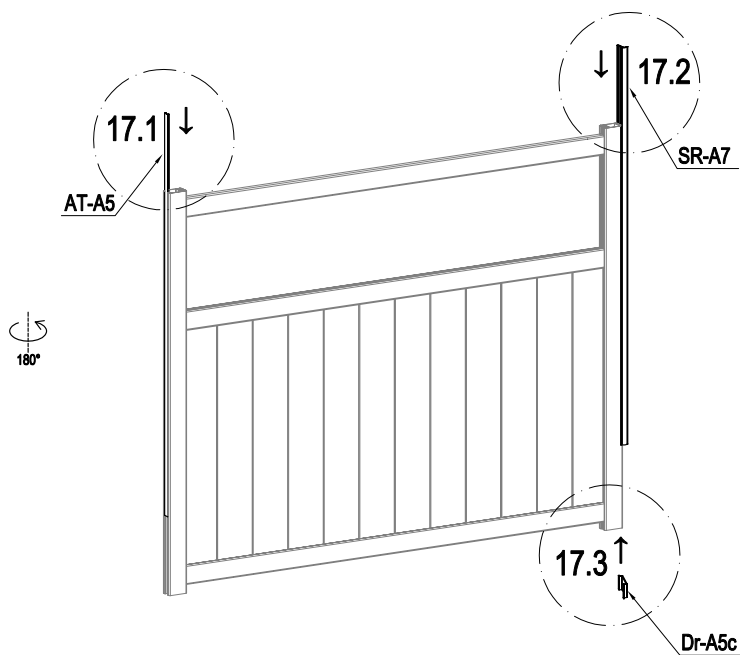

	DO-C11	4
	DO-30	4



	AT-A5	1
	Dr-A5c	1
	SR-A7	1

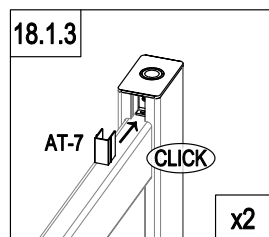
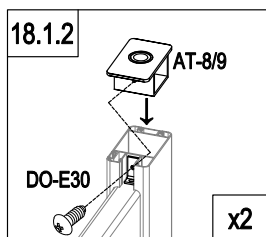
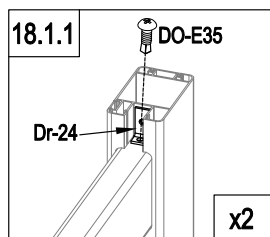
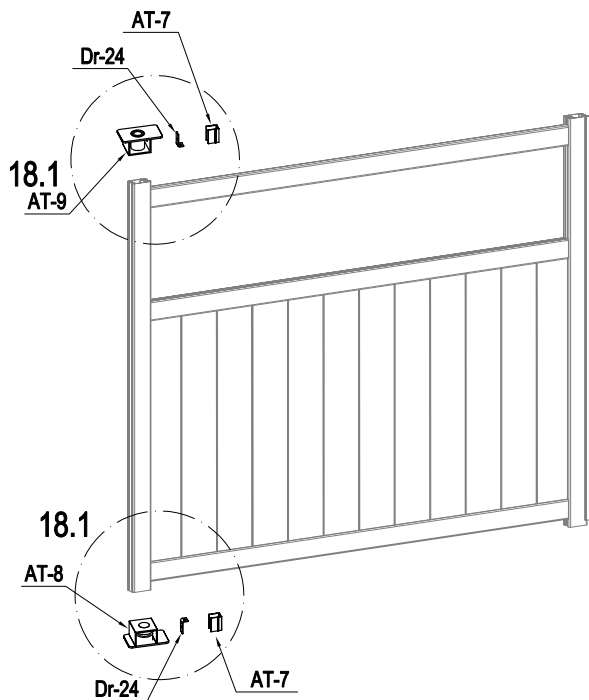

	AT-8	1
	AT-9	1
	Dr-24	2

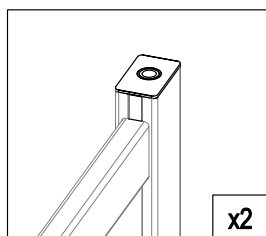

	AT-7	2
	DO-E30	2
	DO-E35	2

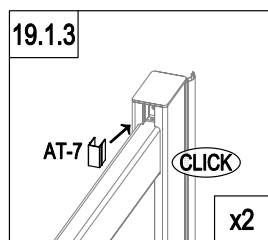
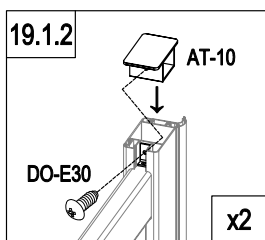
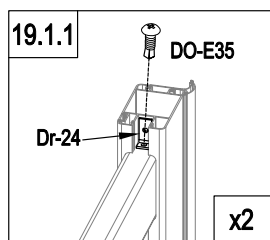
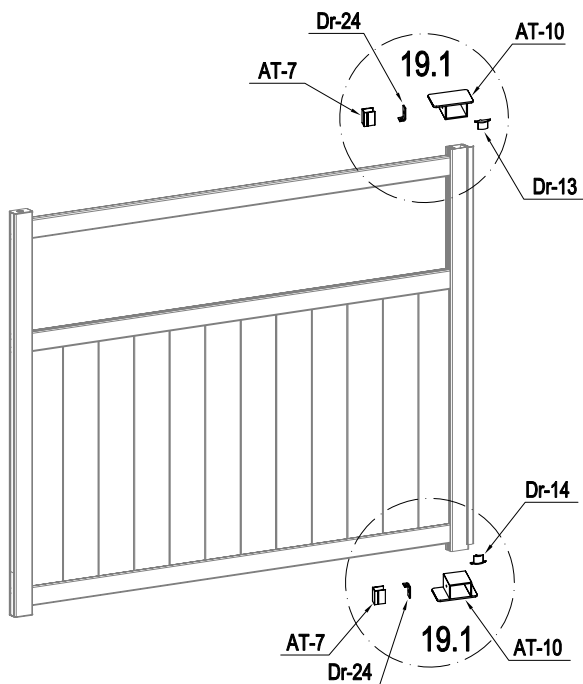

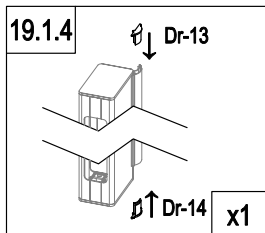

	AT-10	2
	Dr-24	2
	AT-7	2
	Dr-13	1

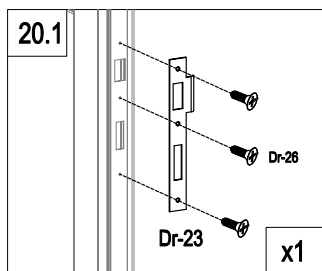
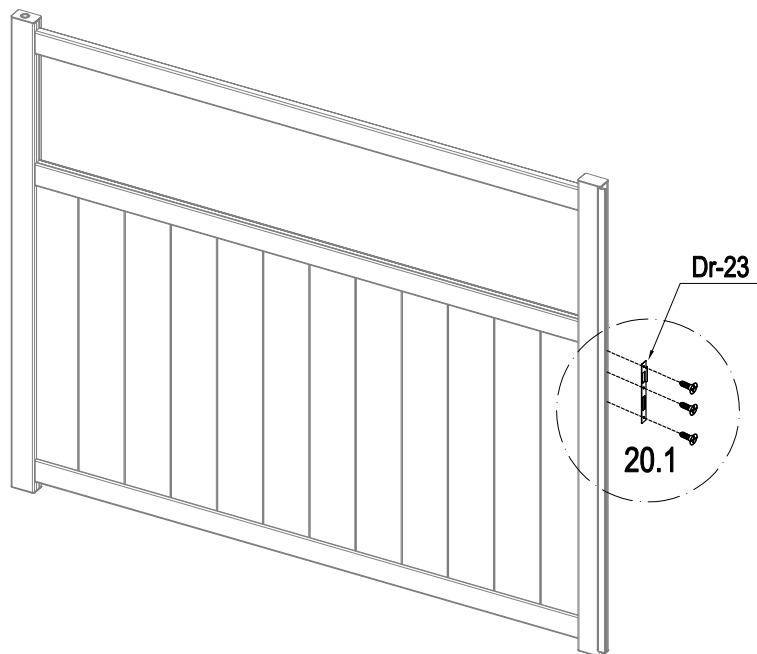

	Dr-14	1
	DO-E30	2
	DO-E35	2



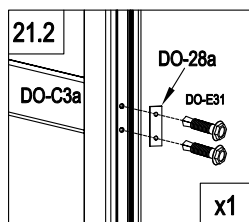
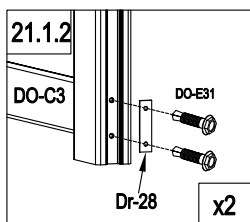
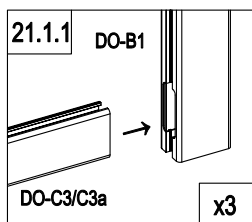
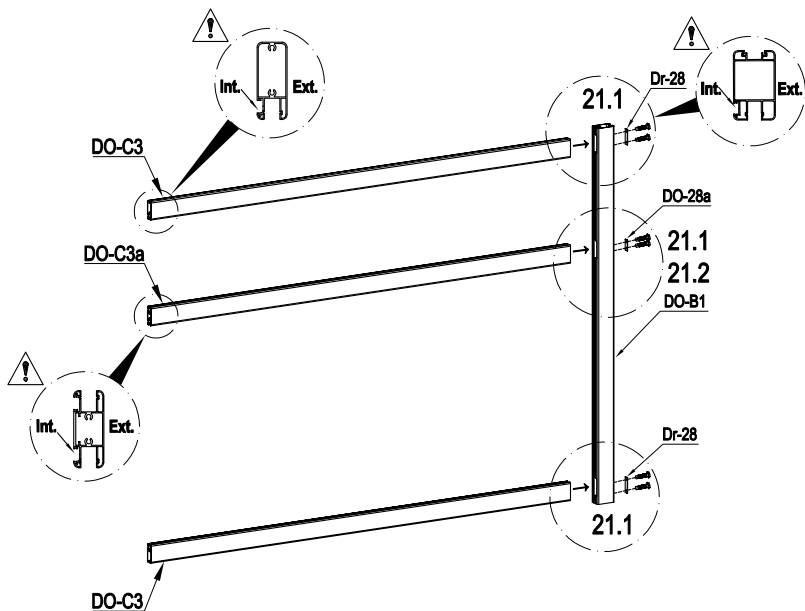

	Dr-23	1
	Dr-26	3

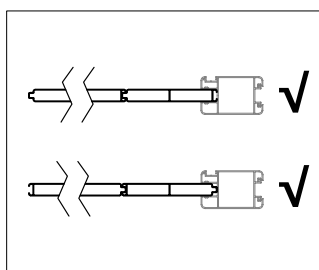
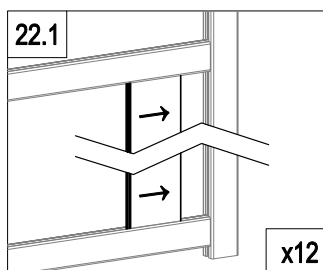
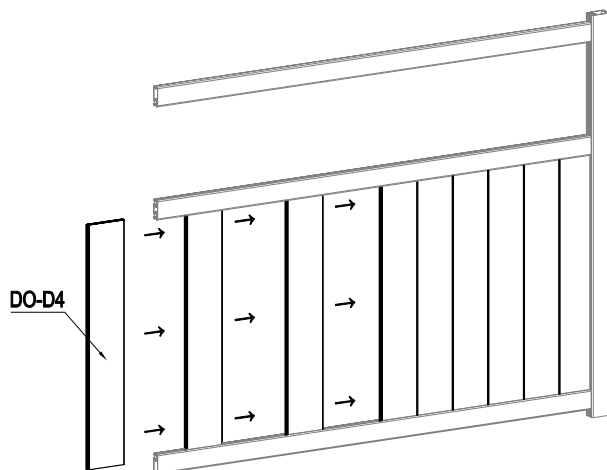

	DO-B1	1
	DO-C3	2
	DO-C3a	1

	Dr-28	2
	DO-28a	1
	DO-E31	6



	DO-D4	12
---	-------	----

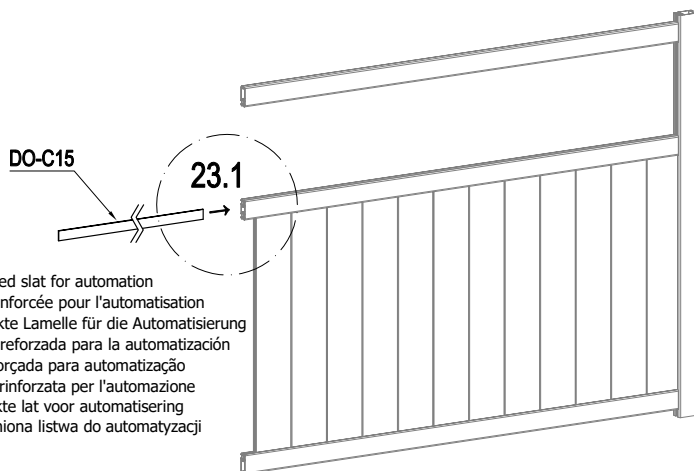

- EN: reinforced slat for automation
 FR : lame renforcée pour l'automatisation
 DE : verstärkte Lamelle für die Automatisierung
 ES : Lámina reforzada para la automatización
 PT: ripa reforçada para automatização
 IT: lamella rinforzata per l'automazione
 NL: versterkte lat voor automatisering
 PL: wzmacniona listwa do automatyzacji

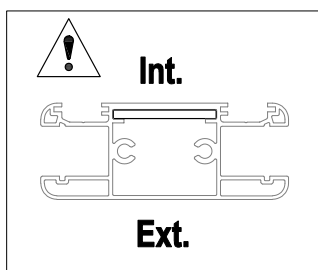
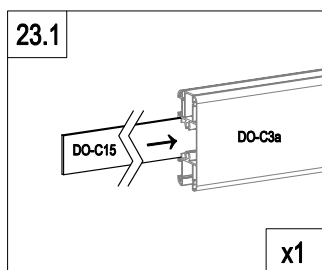

	DO-C15	1
---	--------	---

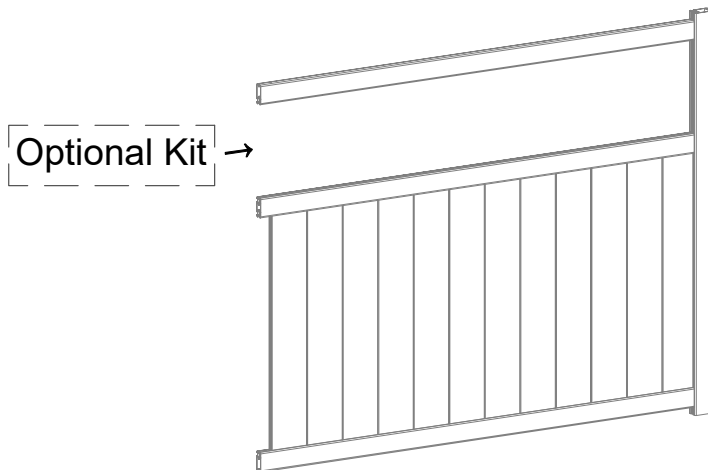

P 32~35

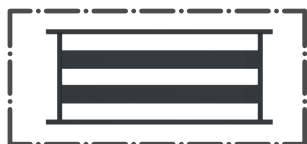

P 36~39



P 40~42

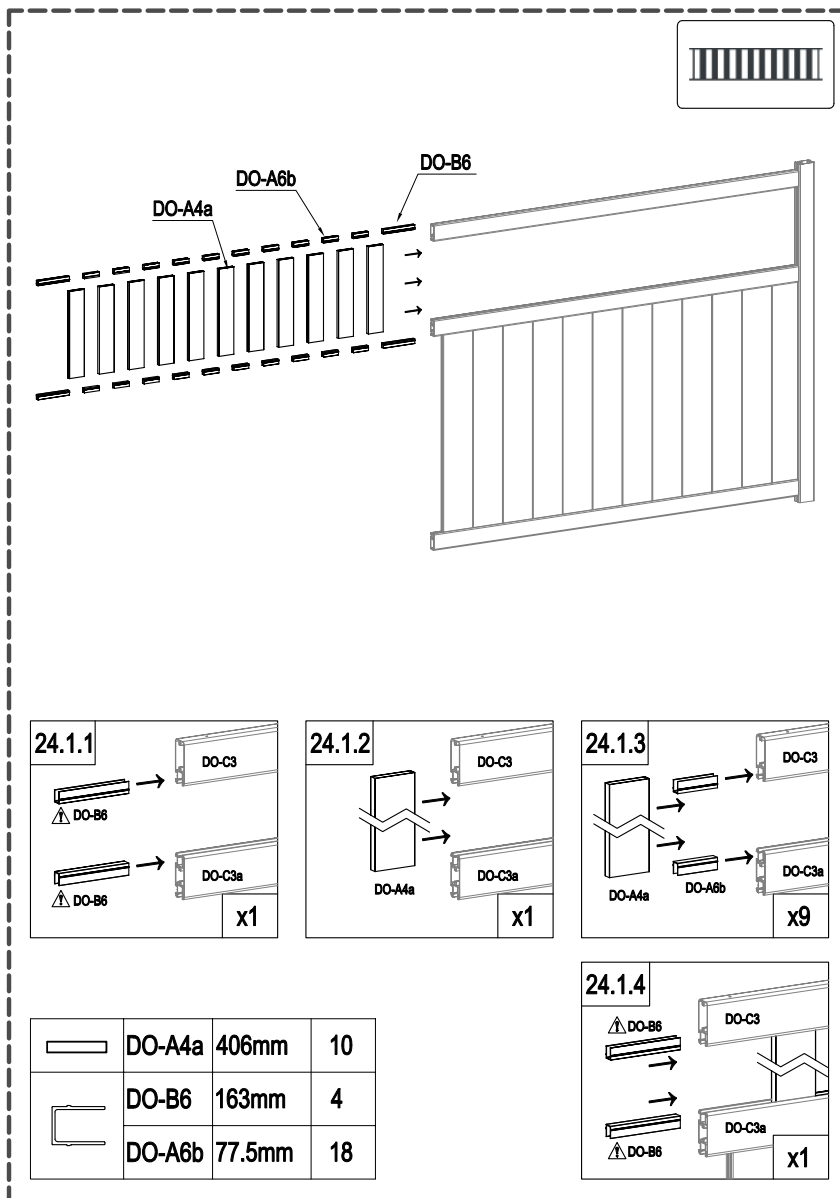

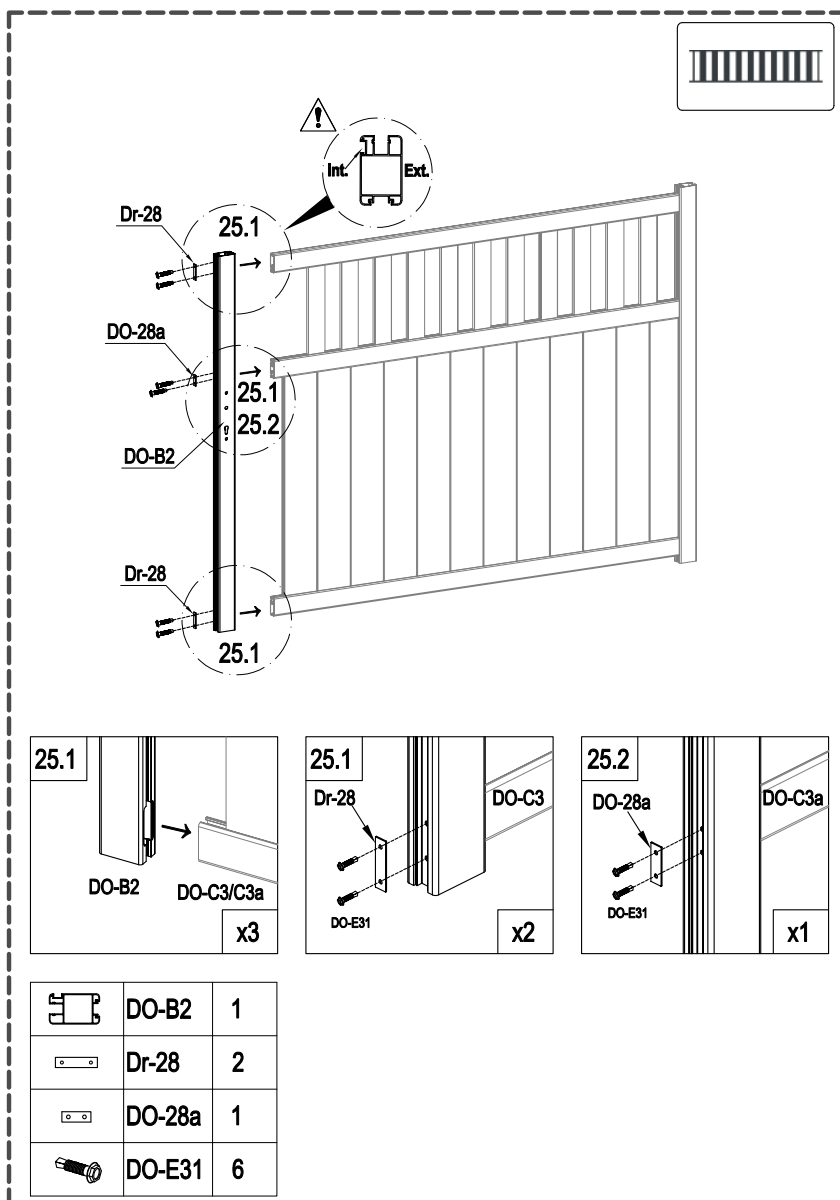

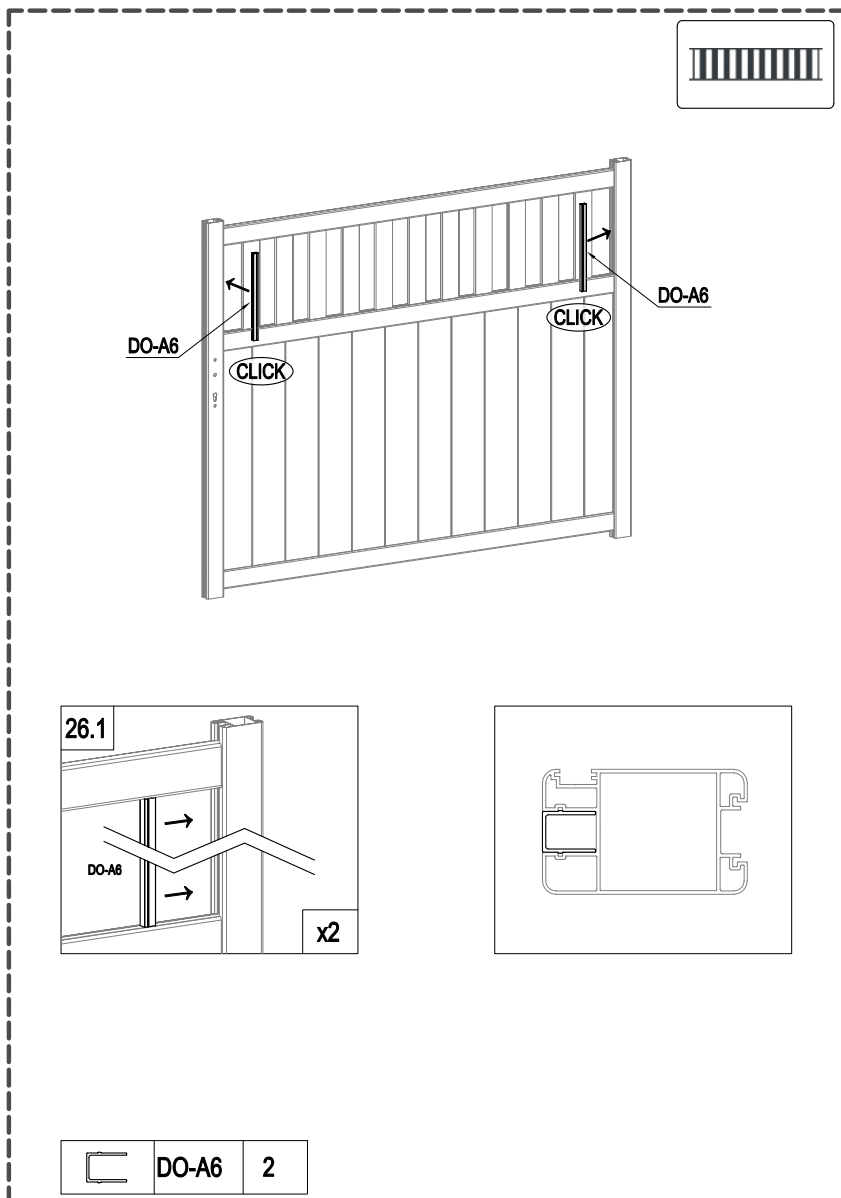

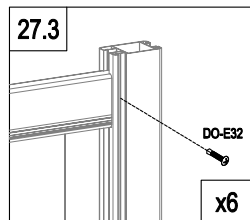
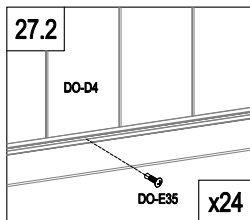
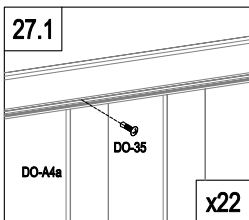
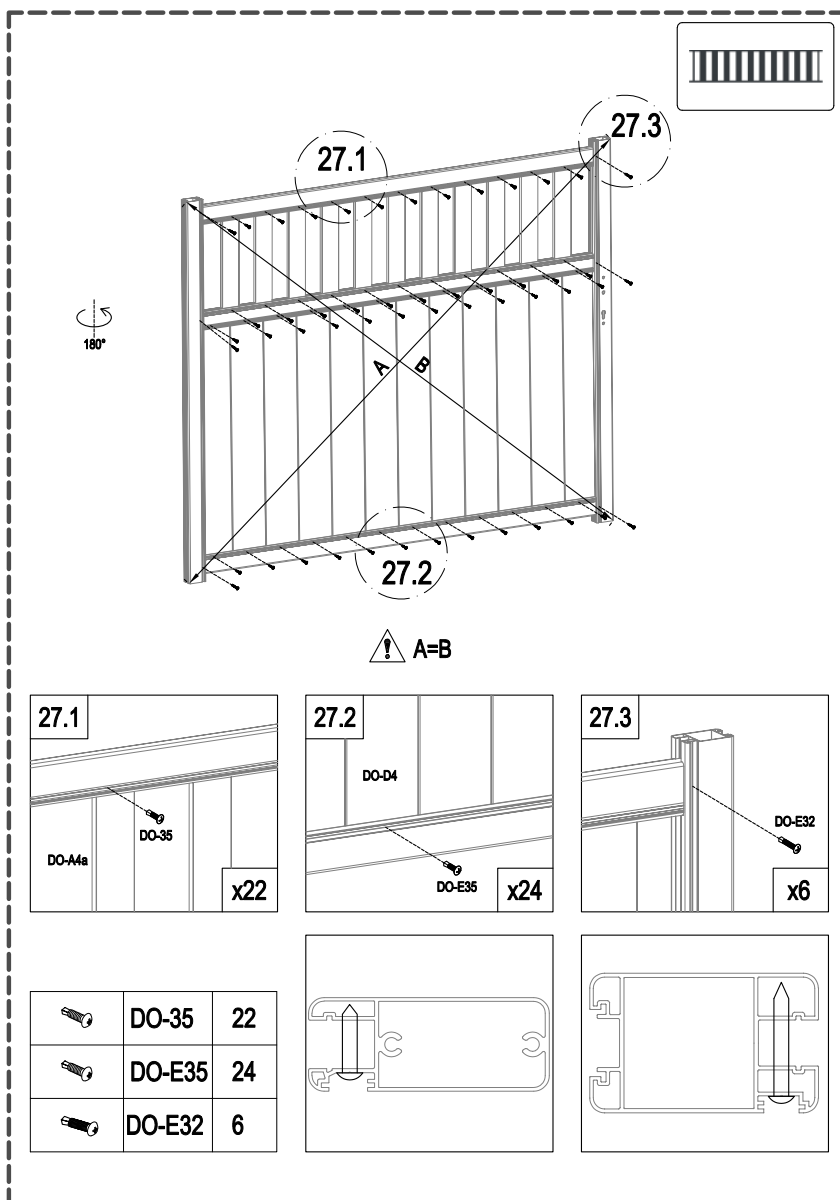

	DO-35	22
	DO-E35	24
	DO-E32	6

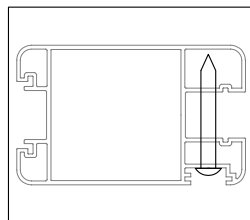
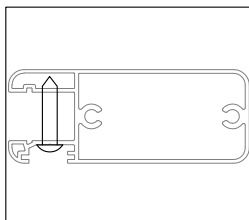

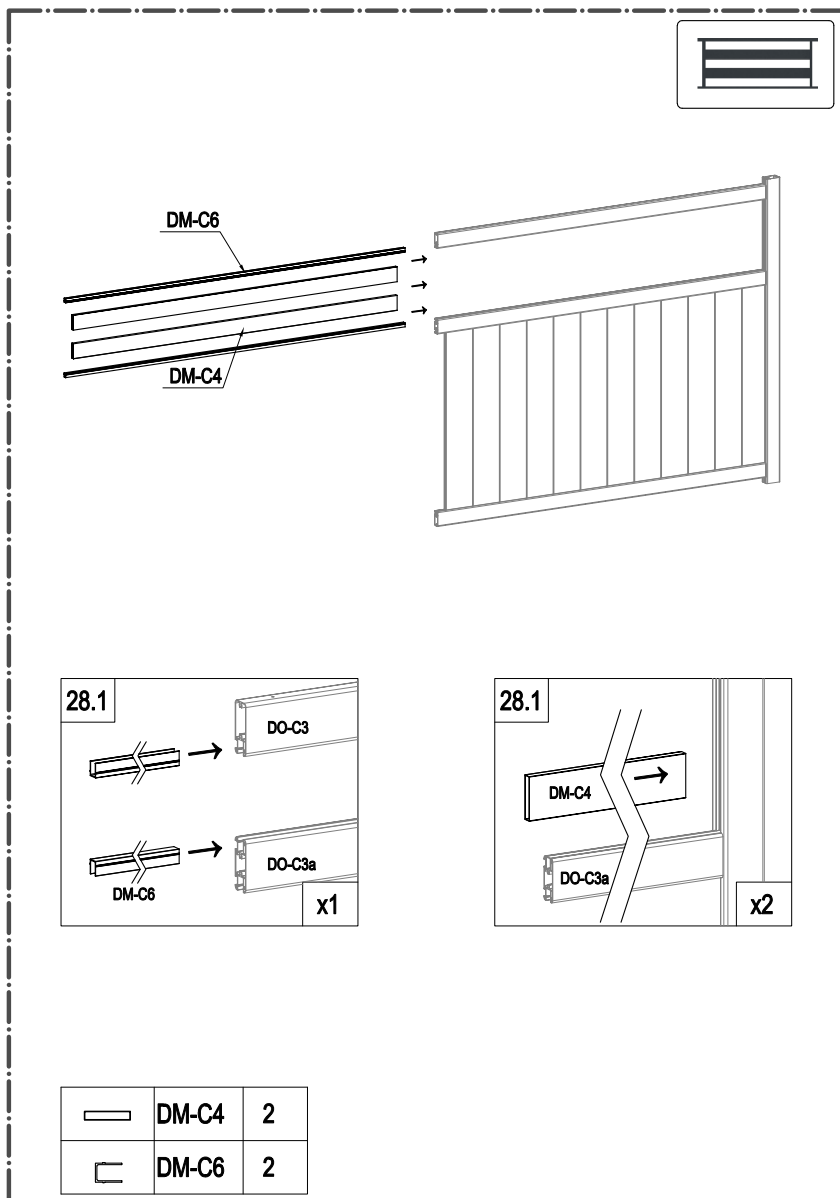

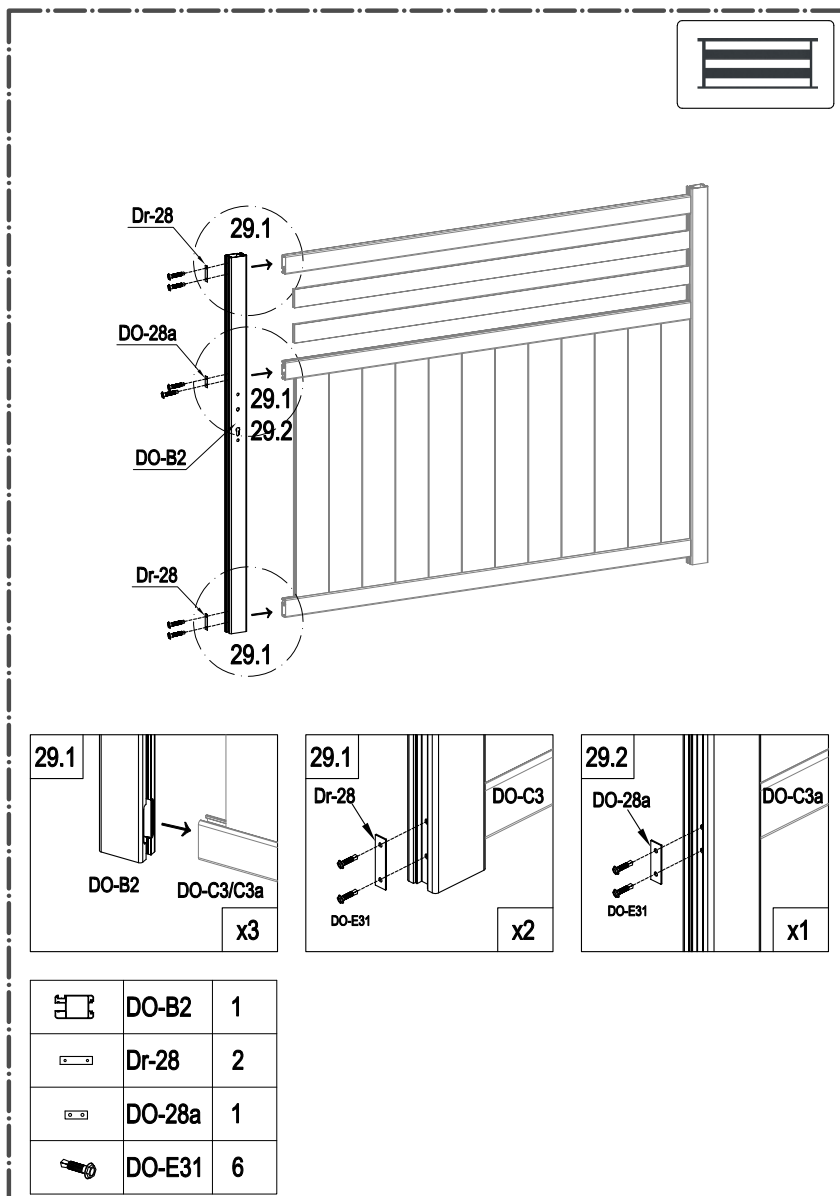

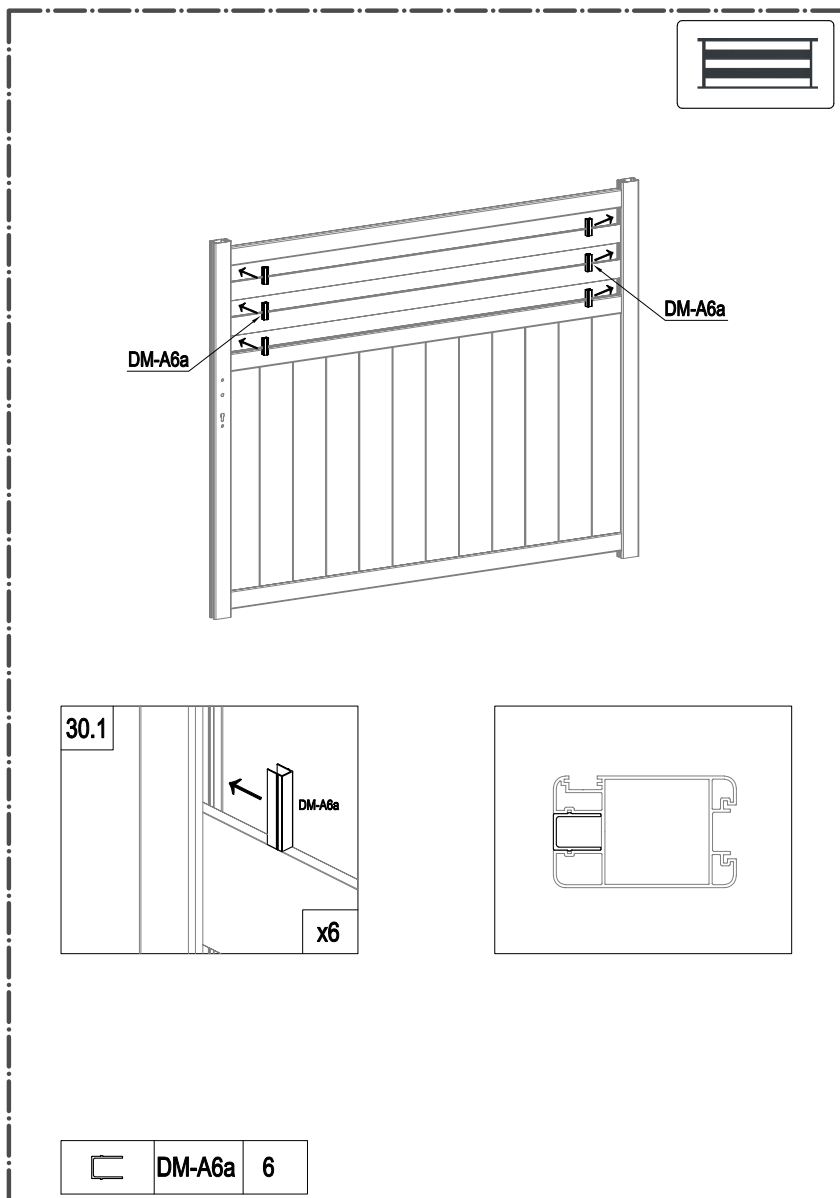

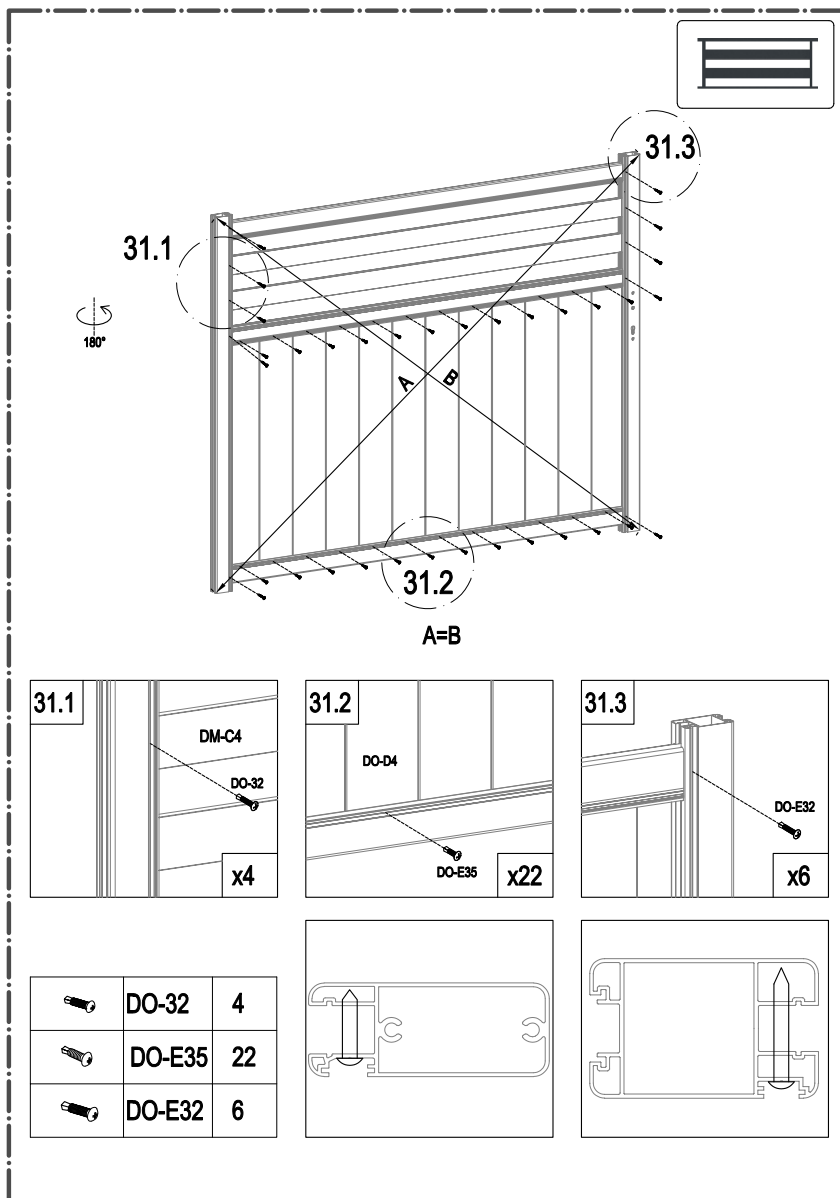

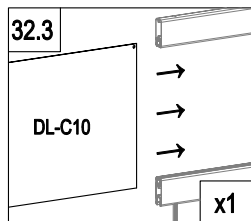
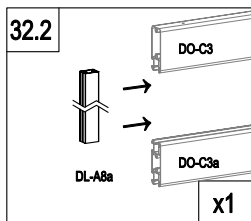
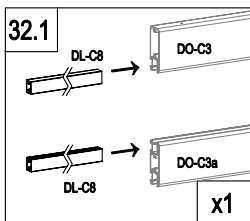
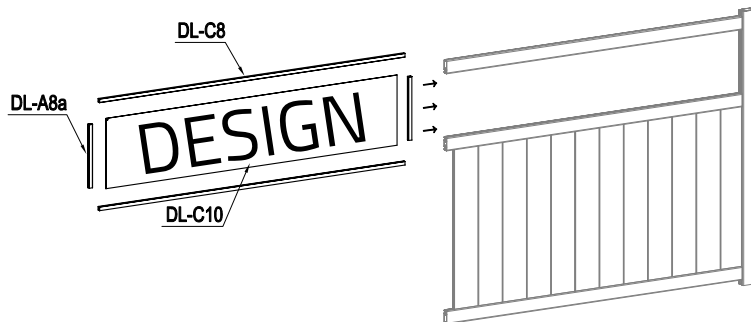

DESIGN



DESIGN	DL-C10	1
	DL-C8	2
	DL-A8a	2

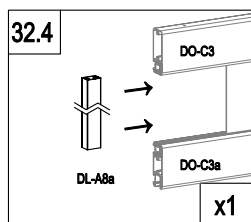

DESIGN

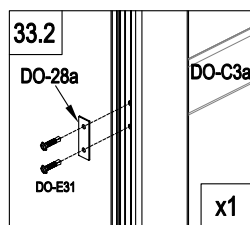
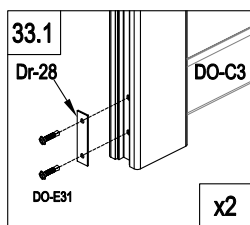
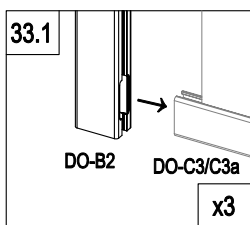
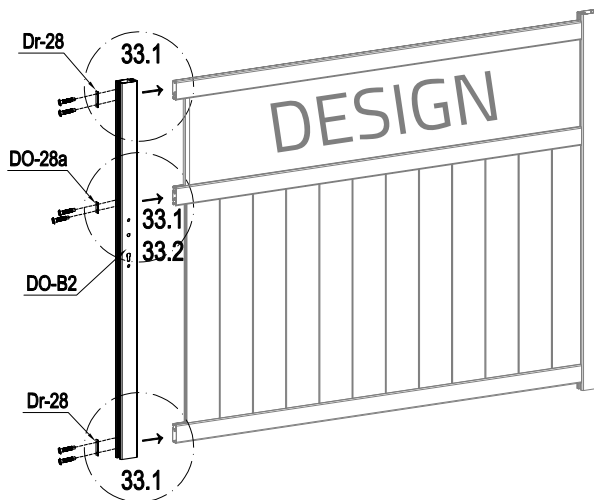

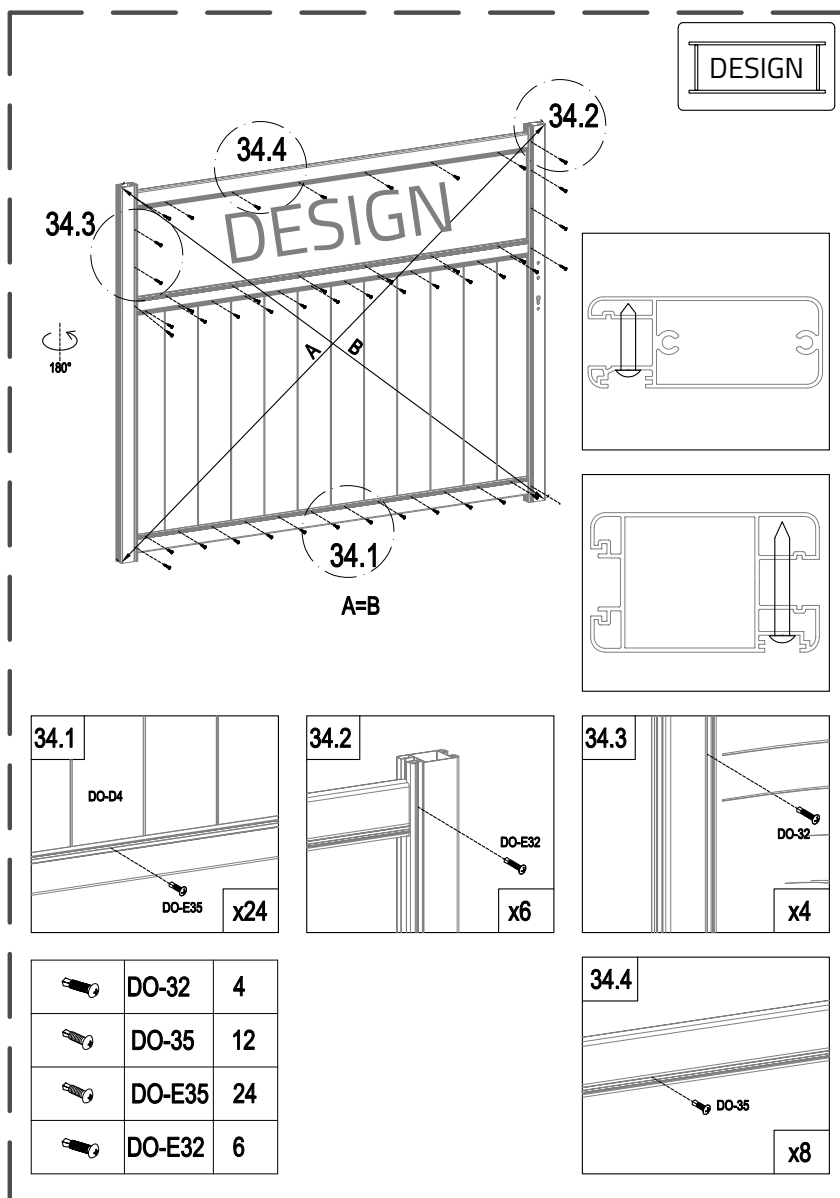

	DO-B2	1
	Dr-28	2
	DO-28a	1
	DO-E31	6

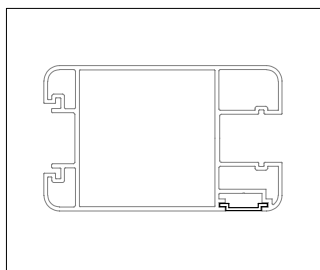
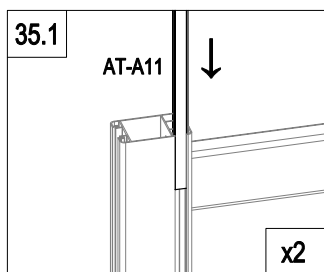
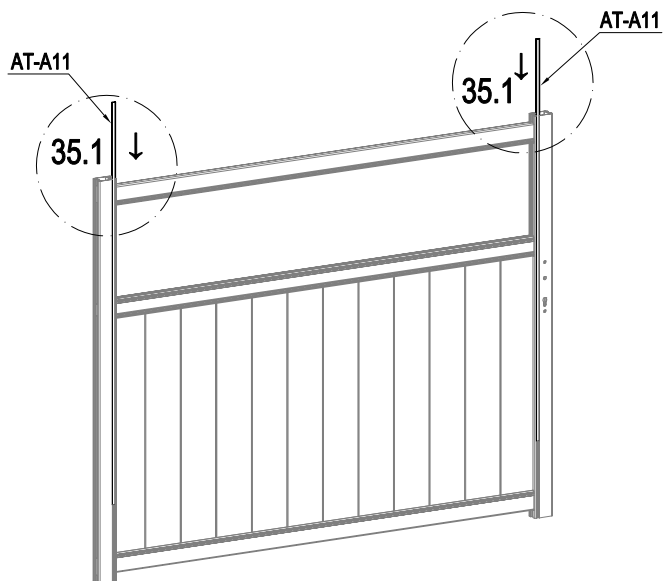

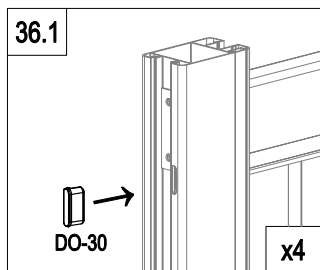
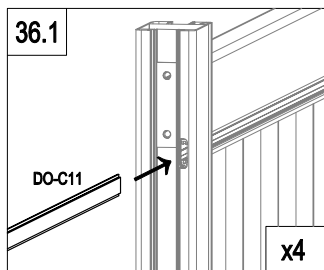
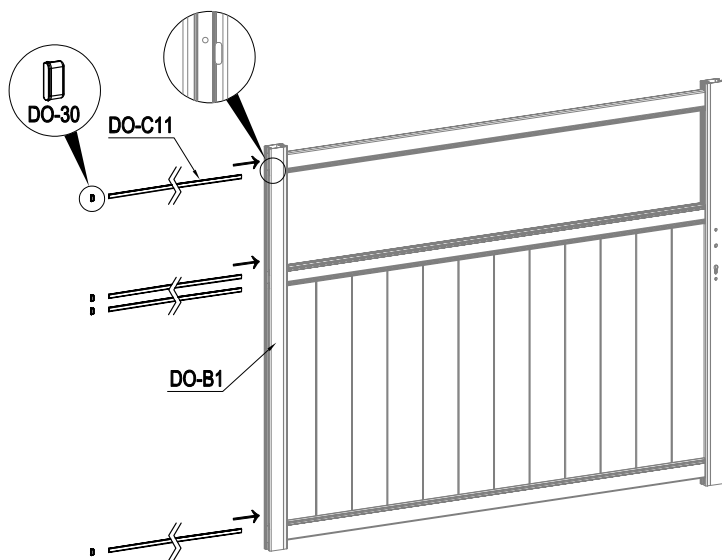

	AT-A11	2
---	--------	---



	DO-C11	4
	DO-30	4

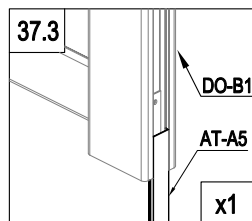
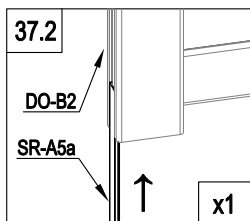
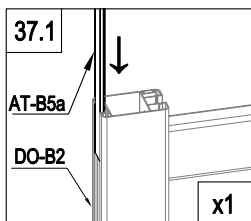
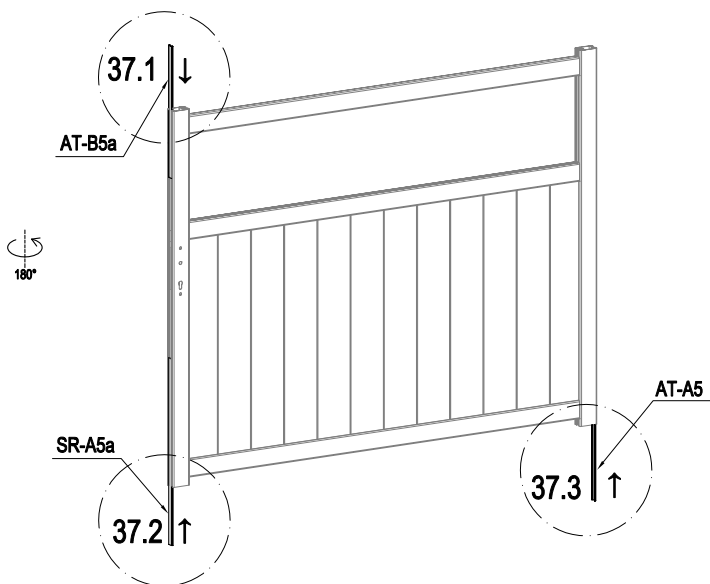

	AT-A5	1
	AT-B5a	1
	SR-A5a	1

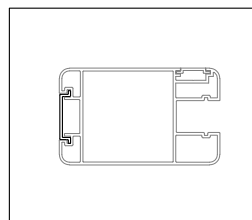

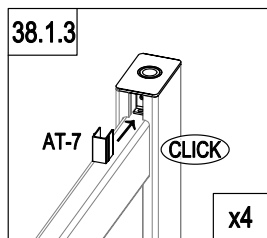
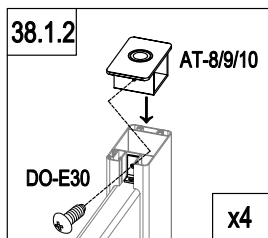
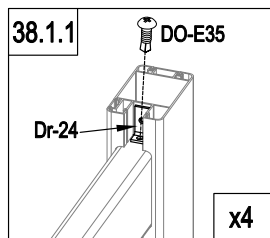
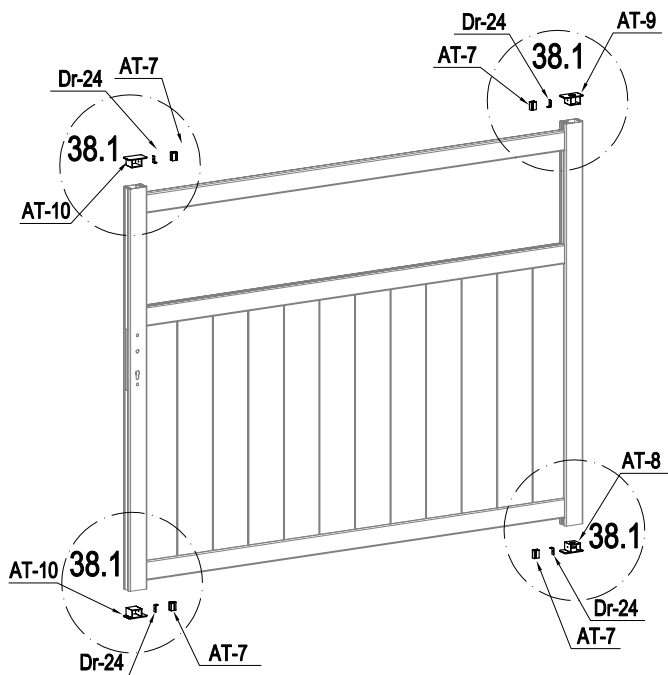

	AT-8	1
	AT-9	1
	AT-10	2
	Dr-24	4

	AT-7	4
	DO-E30	4
	DO-E35	4

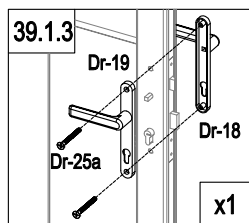
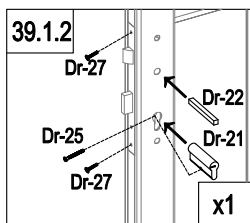
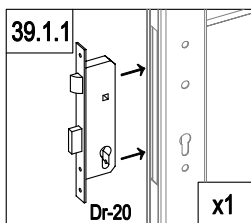
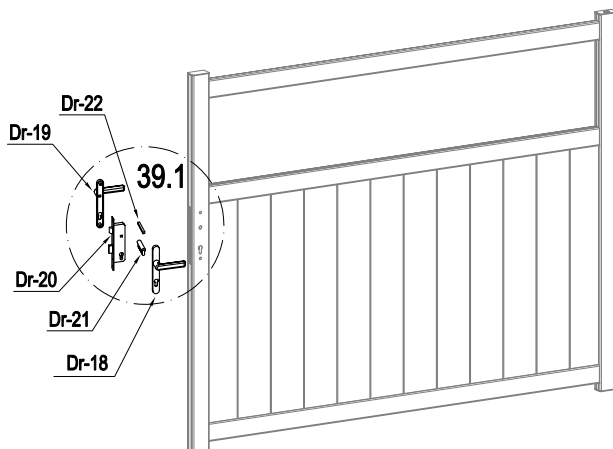

	Dr-20	1
	Dr-21	1
	Dr-22	1
	Dr-25	1

	Dr-18	1
	Dr-19	1
	Dr-25a	2
	Dr-27	2

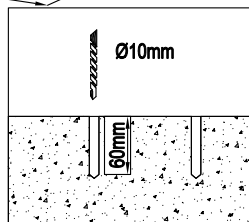
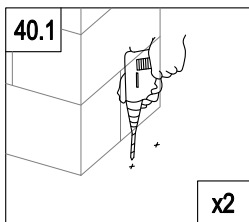
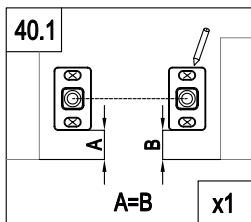
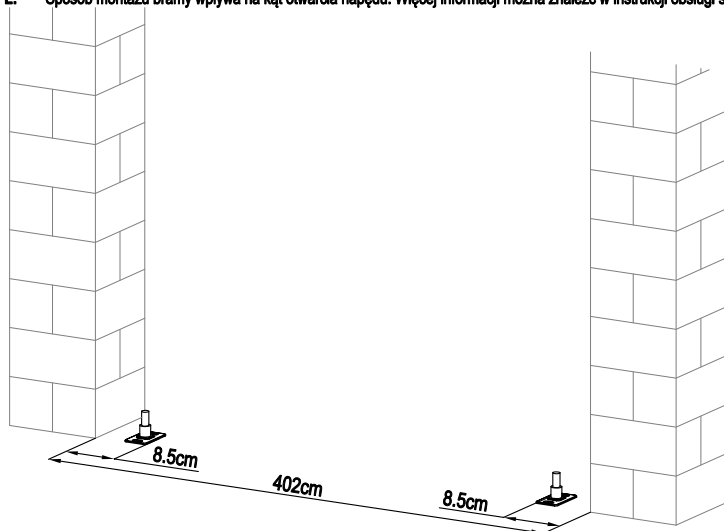

- EN:** The installation of your gate affects the opening angle of the operator. Refer to your motor manual
FR: L'installation de votre portail impacte l'angle d'ouverture de la motorisation. Référez vous à la notice de votre moteur
DE: Der Einbau Ihres Tores beeinflusst den Öffnungswinkel des Antriebs. Siehe Ihr Motorhandbuch
ES: La instalación de su puerta influye en el ángulo de apertura del automatismo. Consulte el manual de su motor
PT: A instalação do seu portão afecta o ângulo de abertura do acionamento. Consultar o manual do motor
IT: L'installazione del cancello influisce sull'angolo di apertura dell'operatore. Consultare il manuale del motore
NL: De installatie van je poort beïnvloedt de openingshoek van de aandrijving. Raadpleeg de handleiding van uw motor
PL: Sposób montażu bramy wpływa na kąt otwarcia napędu. Więcej informacji można znaleźć w instrukcji obsługi silnika



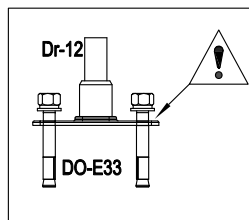
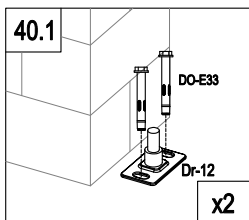

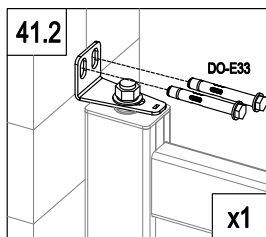
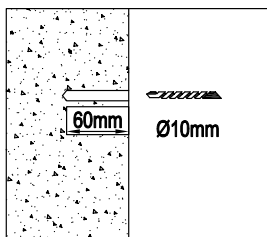
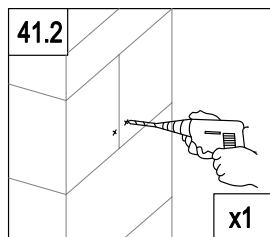
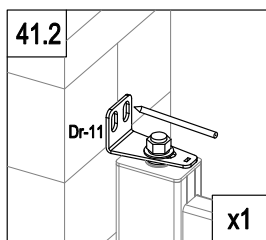
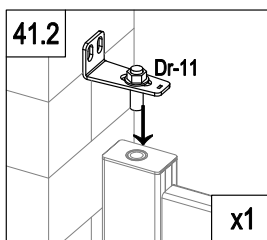
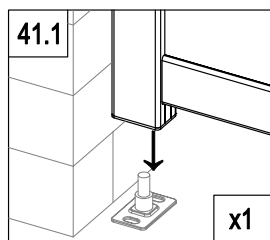
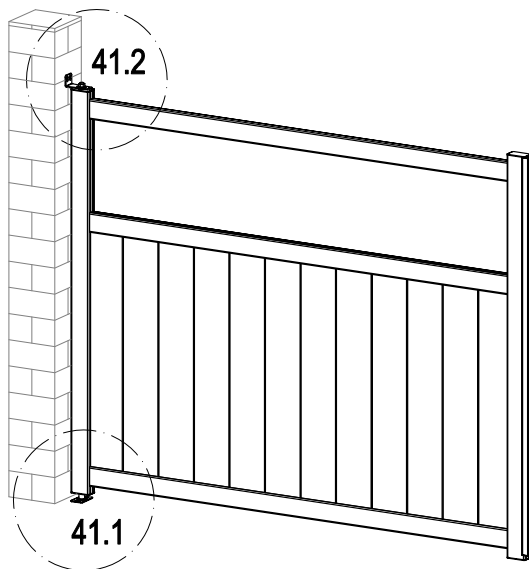
	Dr-12	2
	DO-E33	4





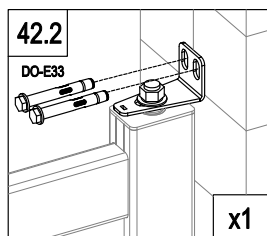
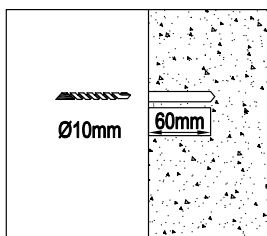
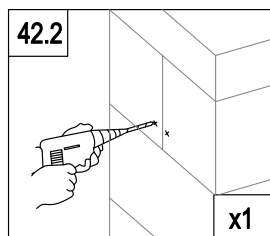
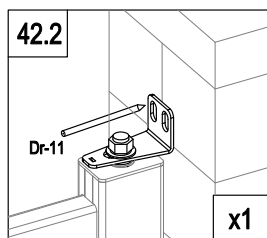
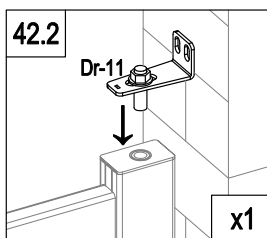
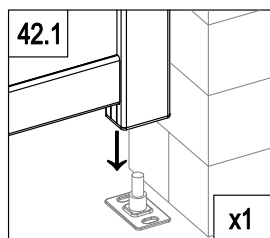
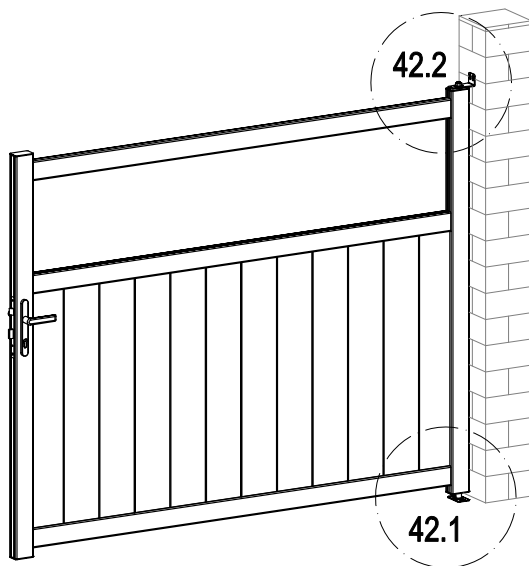

	Dr-11	1
	DO-E33	2



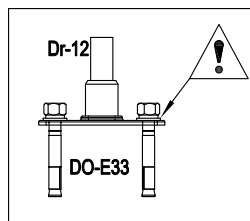
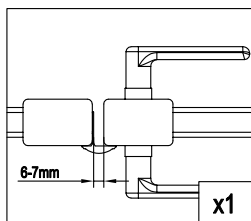
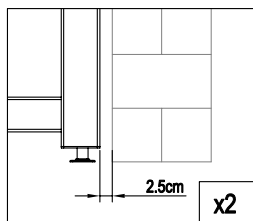
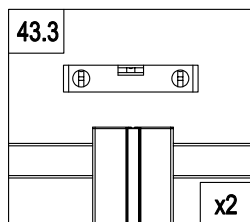
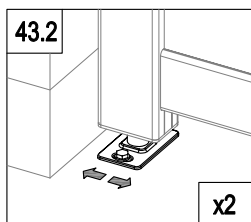
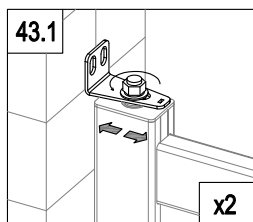
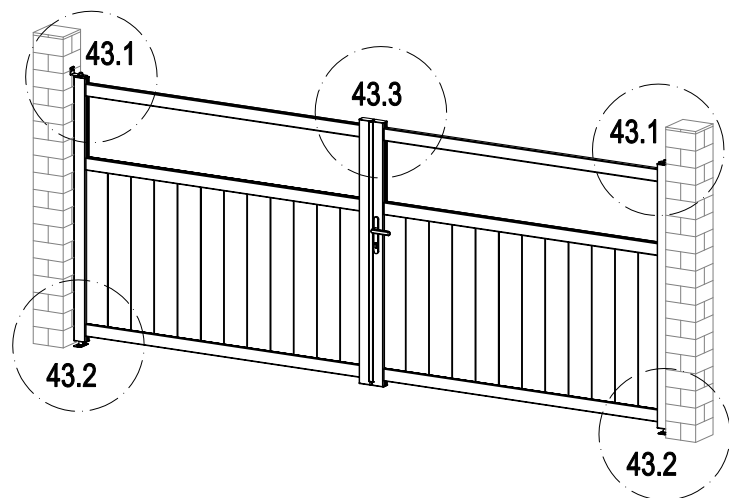

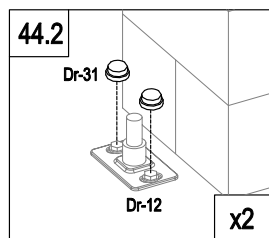
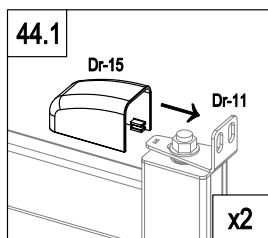
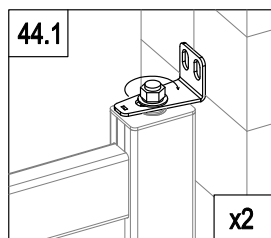
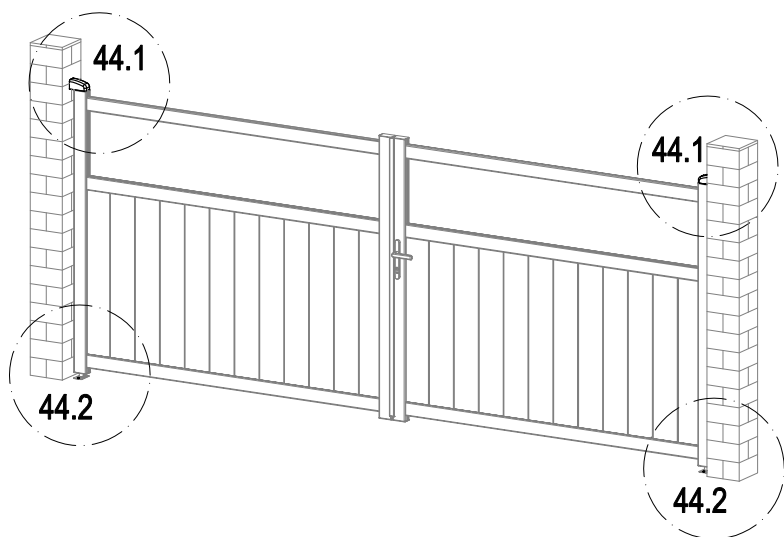

	Dr-11	1
	DO-E33	2



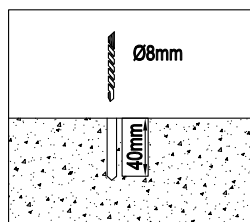
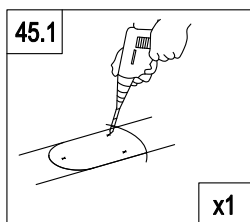
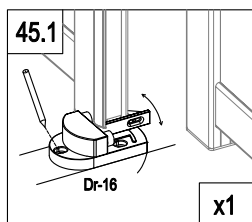
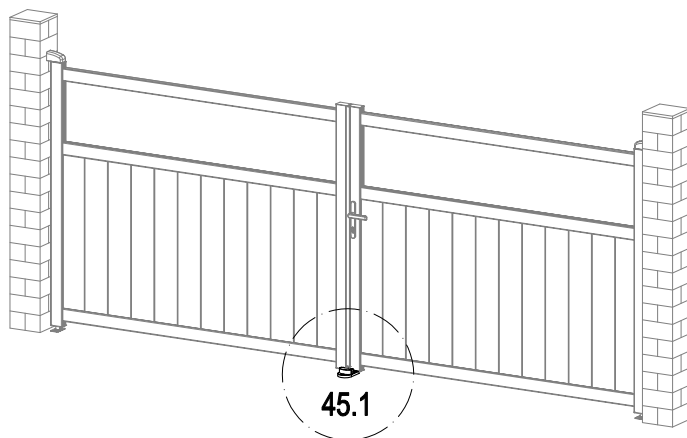



	Dr-15	2
	Dr-31	4

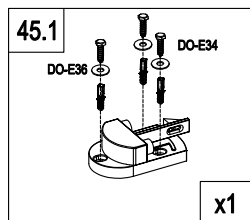

	Dr-16	1
	DO-E34	3
	DO-E36	3

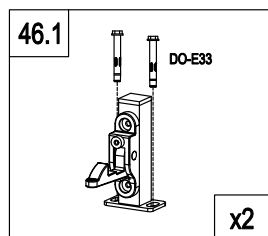
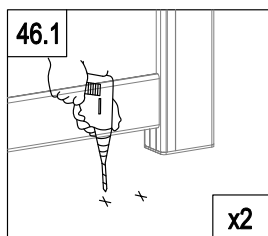
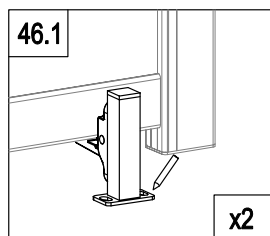
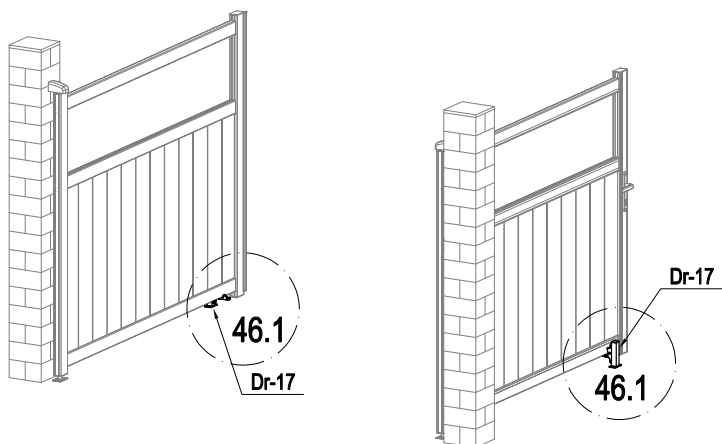



	DO-E33	4
	Dr-17	2