

CASANOVO

CALANCIA 350B180

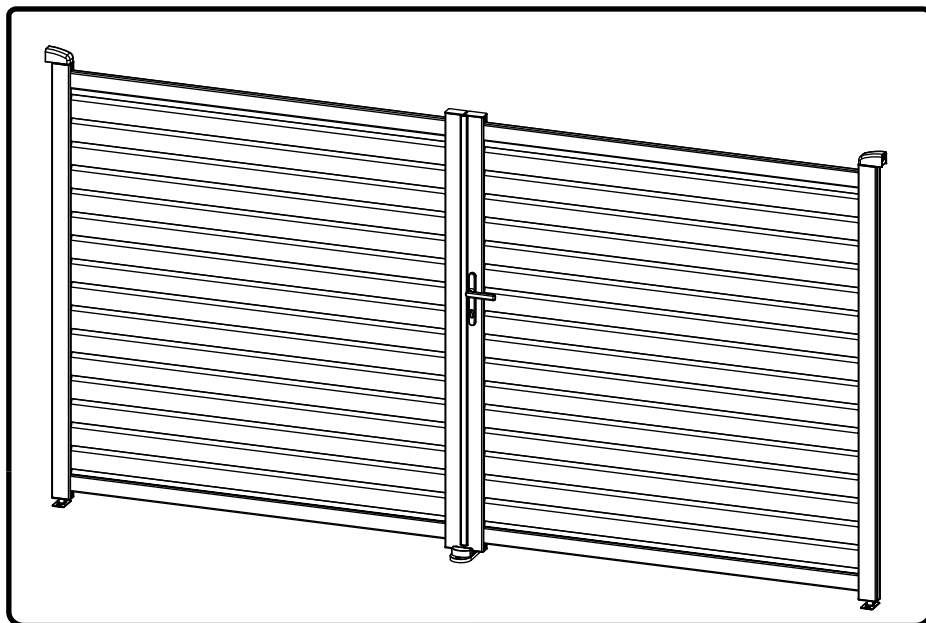

6-7H



X 2

EN FR DE ES PT IT NL PL FI SE DK
RO SI SK HU CZ HR GR LT LV



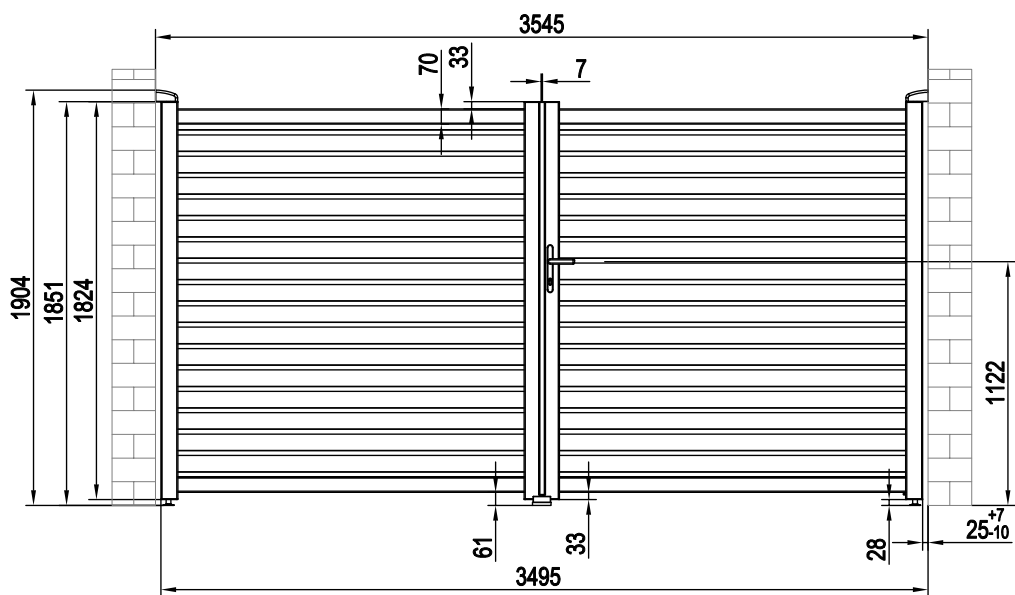

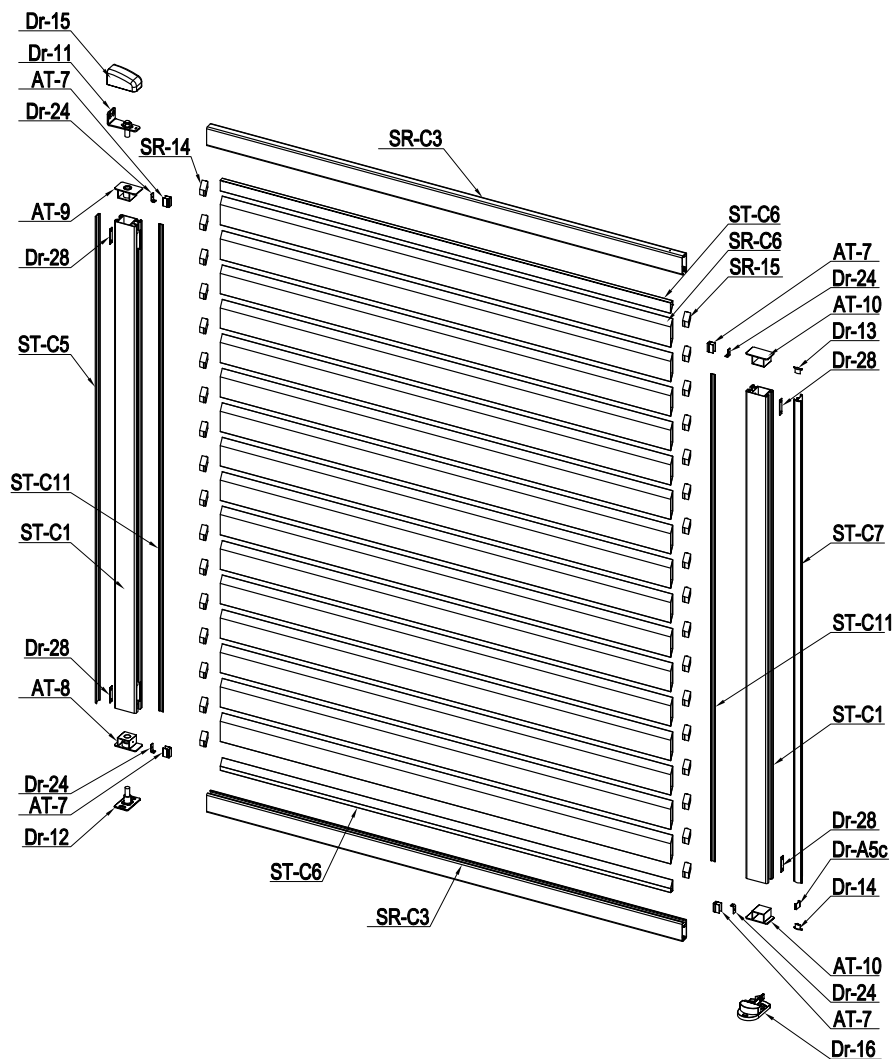

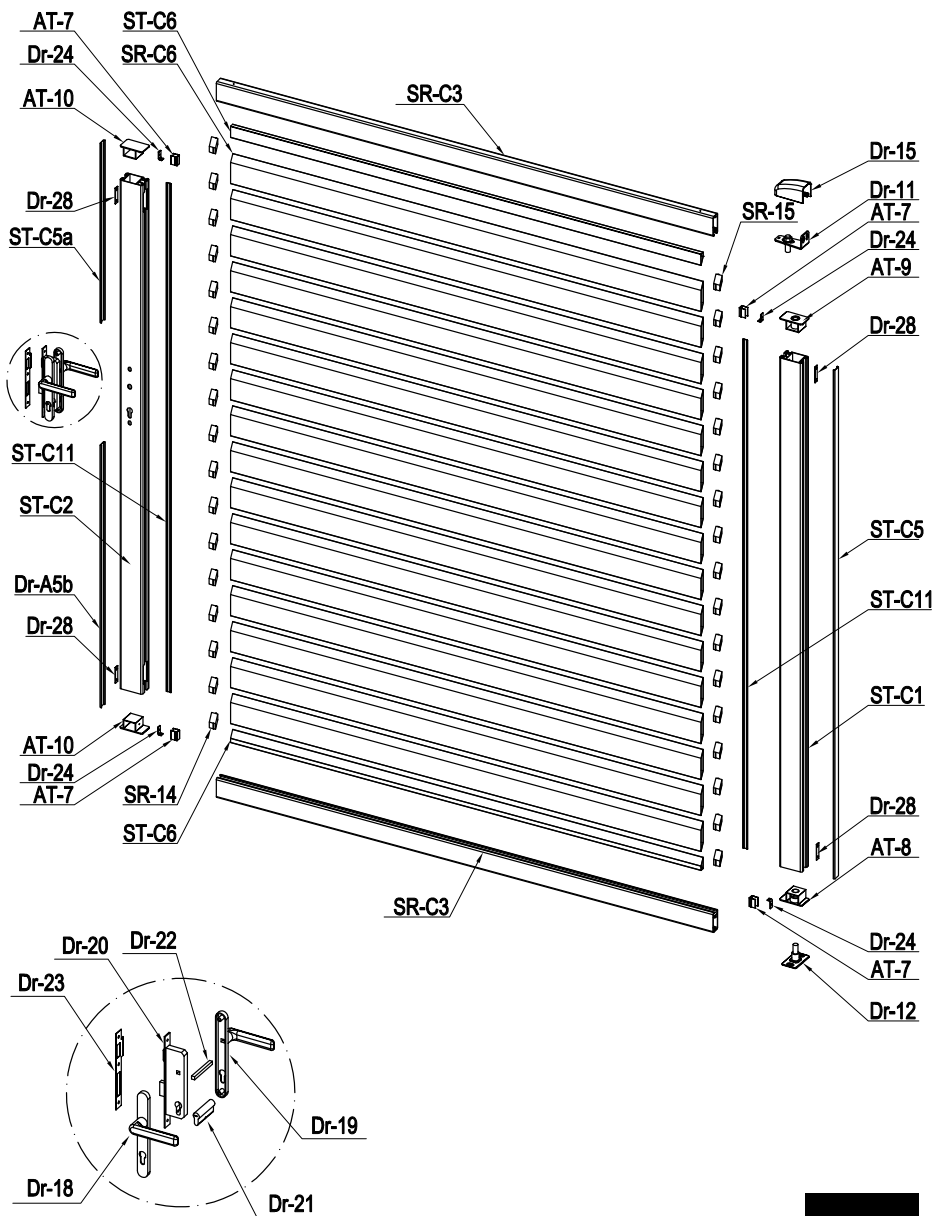

































INSTRUCTION MANUAL / NOTICE DE MONTAGE / MONTAGEANLEITUNG / MANUAL DE MONTAJE / MANUAL DE MONTAGEM / MANUALE DI MONTAGGIO /
MONTAGEHANDLEIDING / INSTRUKCJA MONTAŻU / KÄYTTÖOHJEET / BRUKSANVISNING / BRUGSANVISNING / INSTRUCIUNI DE ASAMBLARE /
NAVODILA ZA SESTAVLJANJE / NÁVOD NA MONTÁŽ / ÖSSZESZERELÉSI ÚTMUTATÓ / NÁVOD K MONTÁŽI / UPUTE ZA INSTALACIJU /
ΟΔΗΓΙΕΣ ΣΥΝΑΡΜΟΛΟΓΗΣΗΣ / SURINKIMO INSTRUKCIJOS / MONTĀŽAS INSTRUKCIJAS











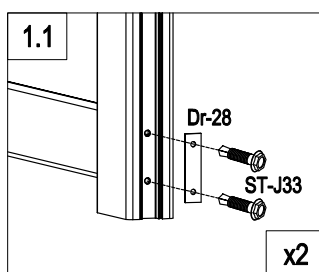
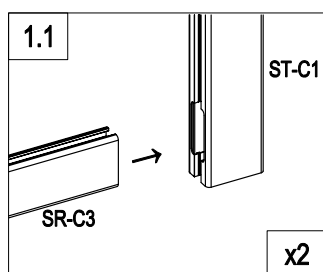
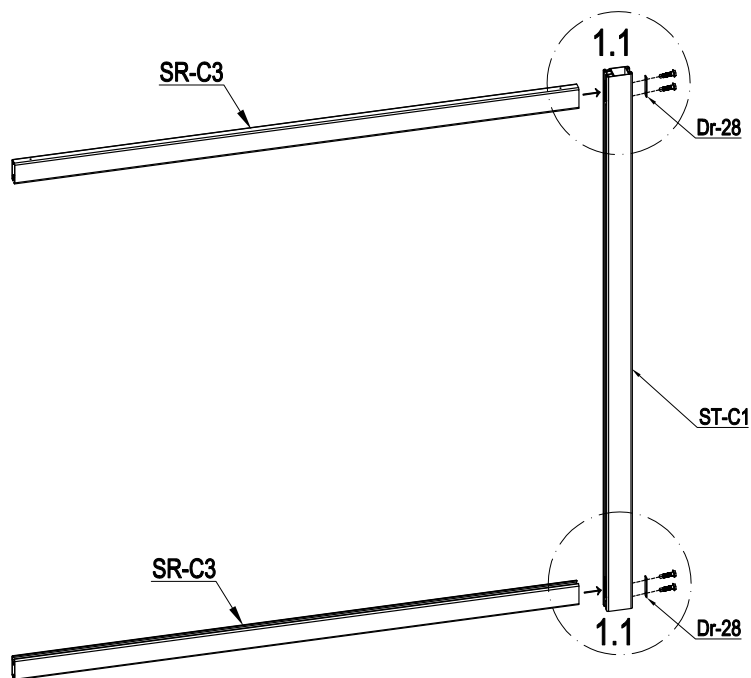

PART LIST

IMAGE	NO.	L.(mm)	QTY	IMAGE	NO.	L.(mm)	QTY
	ST-C1	1818	3		Dr-16		1
	ST-C2	1818	1		Dr-17		2
	SR-C3	1721	4		Dr-31		4
	SR-C6	1630	32		Dr-18		1
	ST-C6	1630	4		Dr-19		1
	ST-C5	1818	2		Dr-20		1
	ST-C5a	640.5	1		Dr-21		1
	Dr-A5b	937	1		Dr-22		1
	Dr-A5c	19.5	1		Dr-23		1
	ST-C11	1818	4		Dr-24		8
	AT-7	29.5	8		Dr-25		1
	ST-C7	1798	1		Dr-25a		2
	AT-8		2		Dr-26		3
	AT-9		2		Dr-27		2
	AT-10		4		Dr-28		8
	Dr-11		2		ST-J30	ST4x10	8
	Dr-12		2		ST-J31	ST4.2x13	8
	Dr-13		1		ST-J32	M8x60	12
	Dr-14		1		ST-J33	ST5.5x38	16
	Dr-15		2		ST-J34	ST6x40	3
	SR-14		34		ST-J35	∅6	3
	SR-15		34		ST-J36	ST4.8x38	72



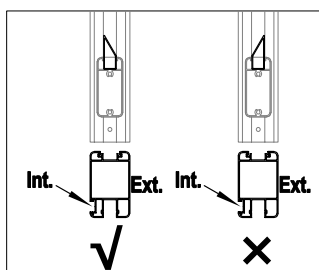
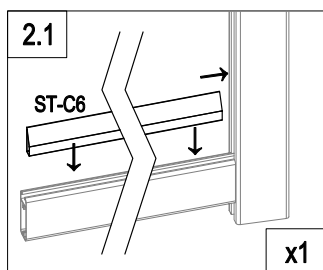
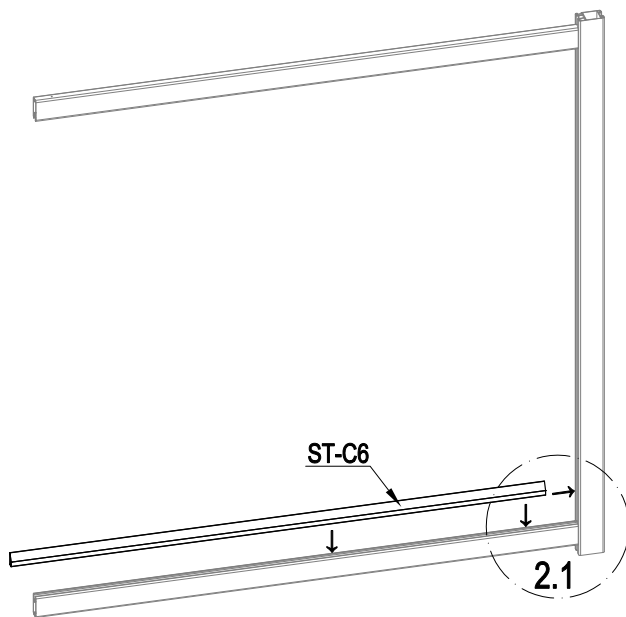

	ST-C1	1
	SR-C3	2
	Dr-28	2
	ST-J33	4

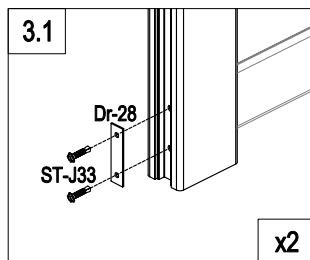
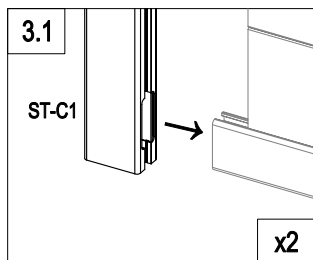
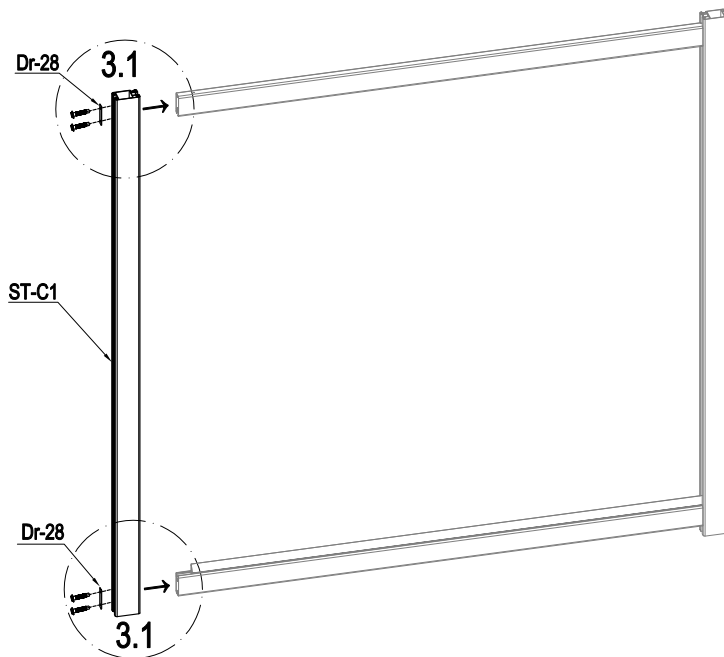

	ST-C6	1
---	-------	---



	ST-C1	1
	Dr-28	2
	ST-J33	4

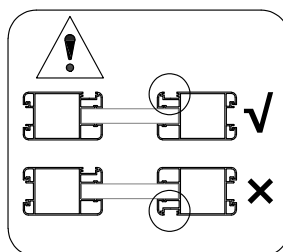

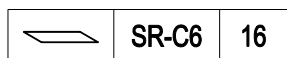
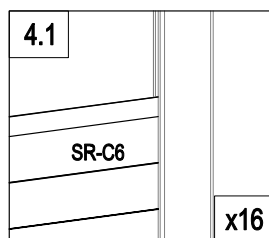
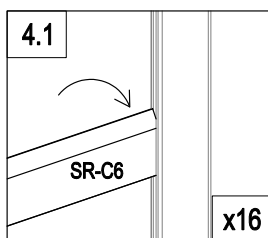
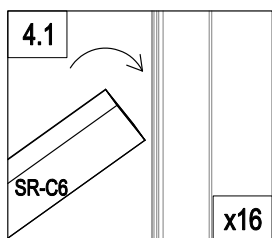
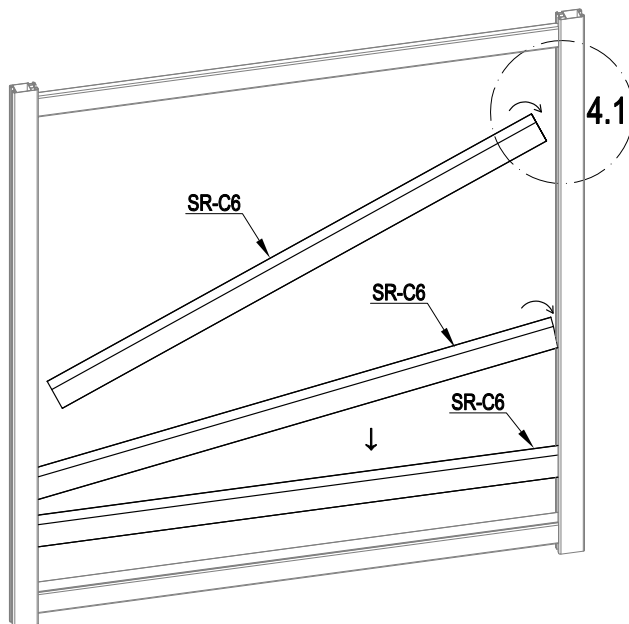

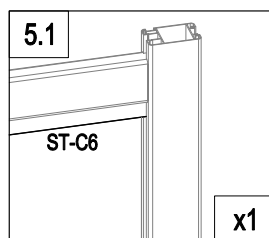
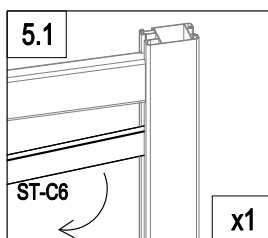
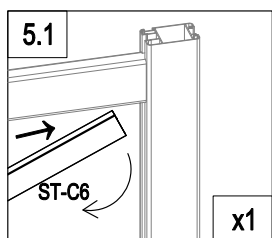
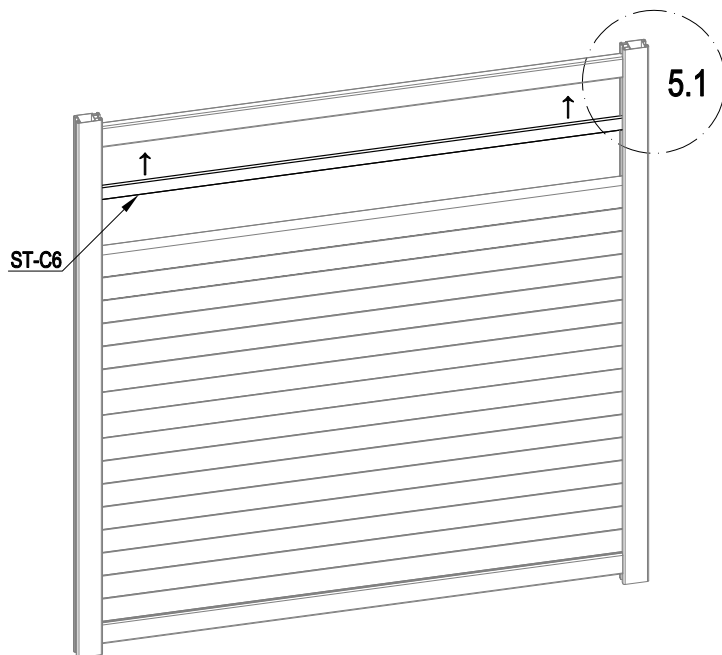



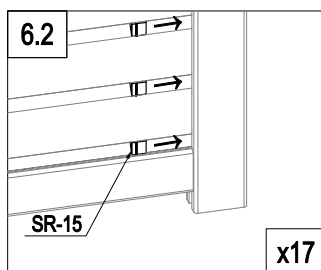
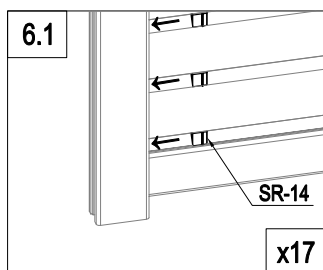
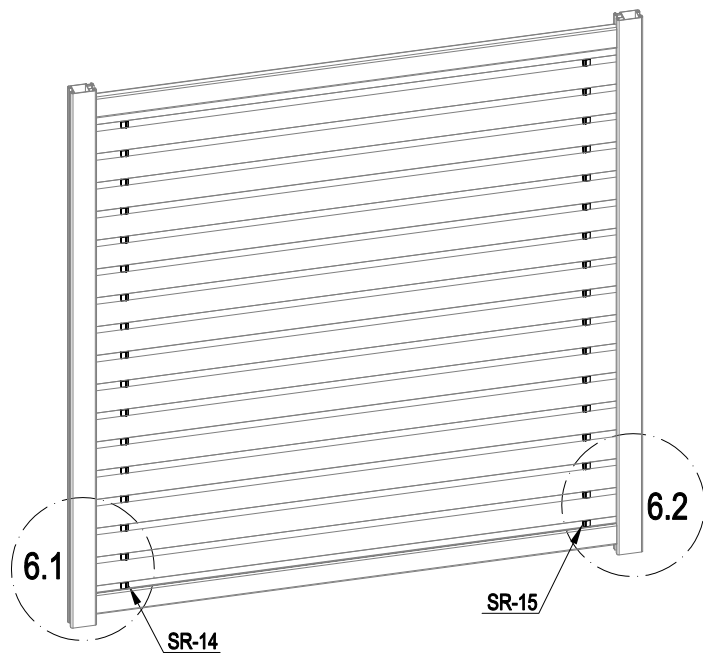

	ST-C6	1
---	-------	---

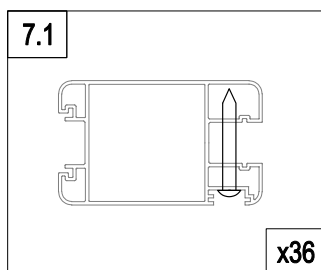
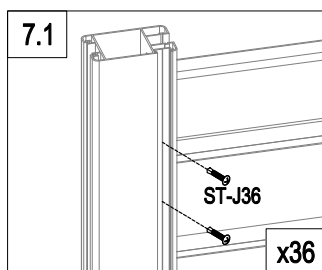
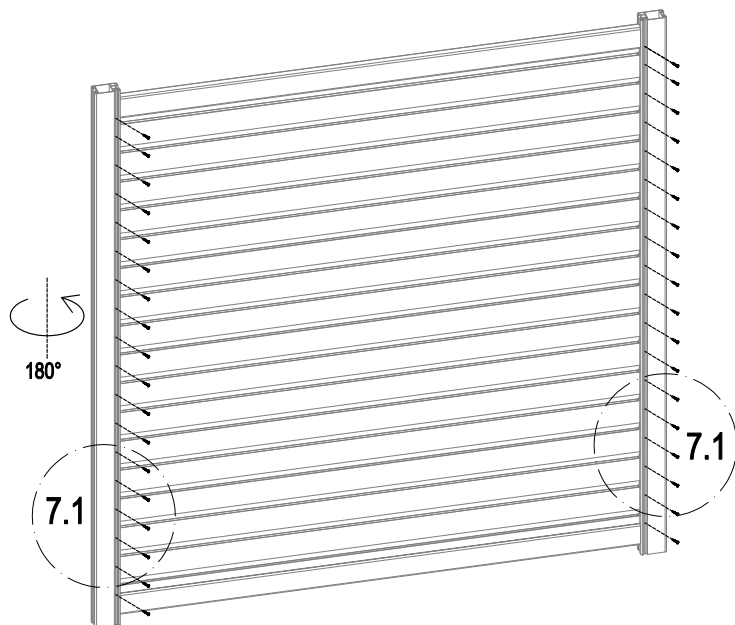

	SR-14	17
	SR-15	17



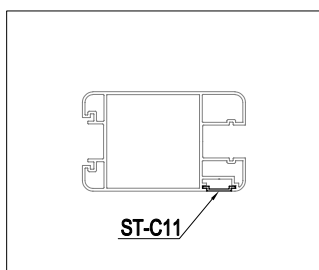
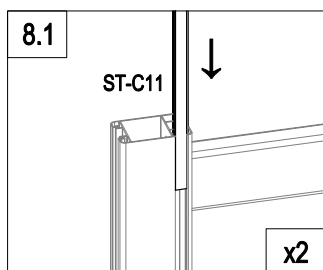
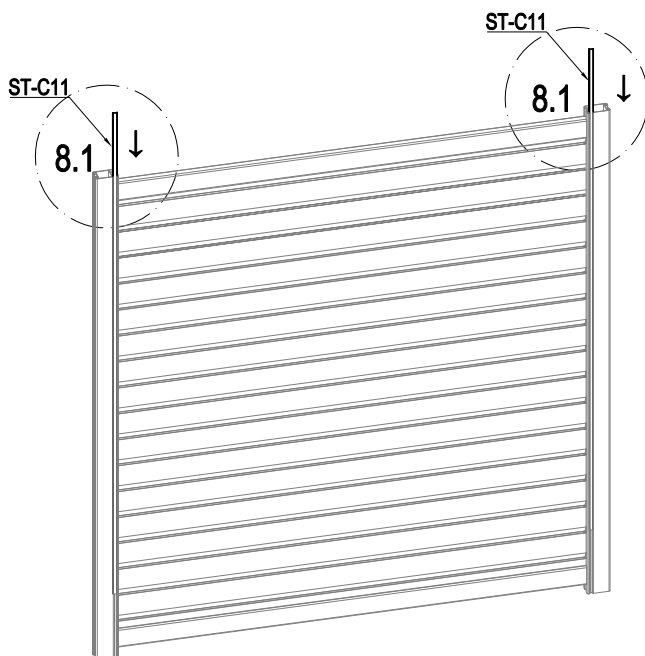

	ST-J36	36
---	--------	----



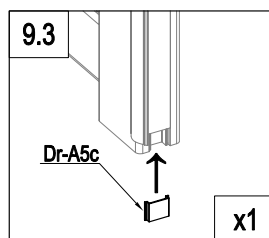
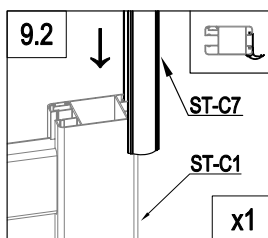
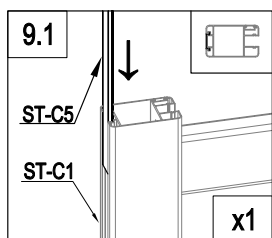
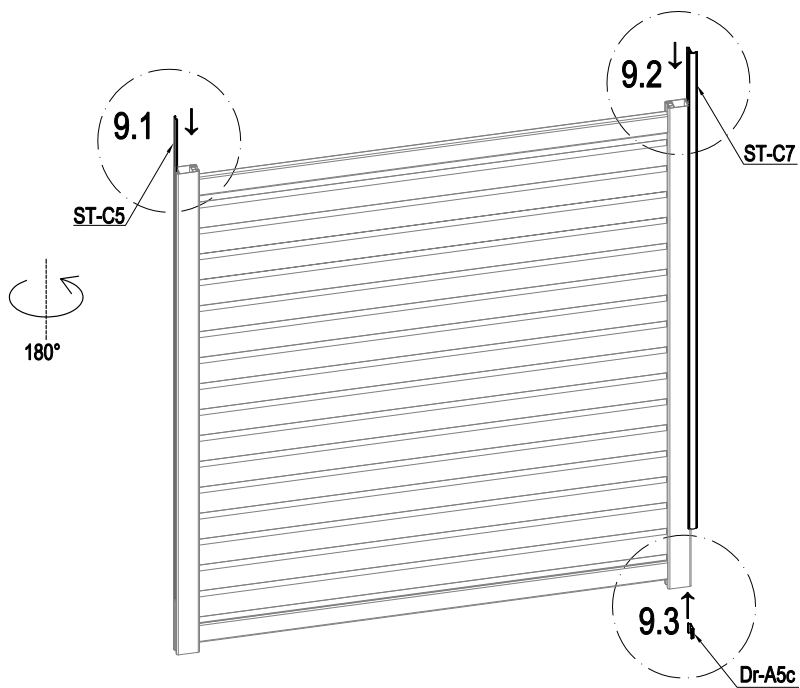



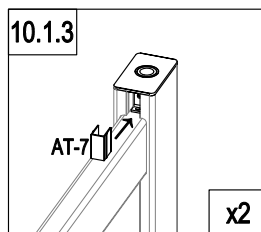
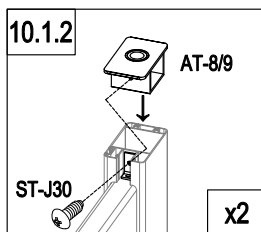
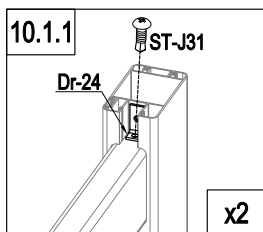
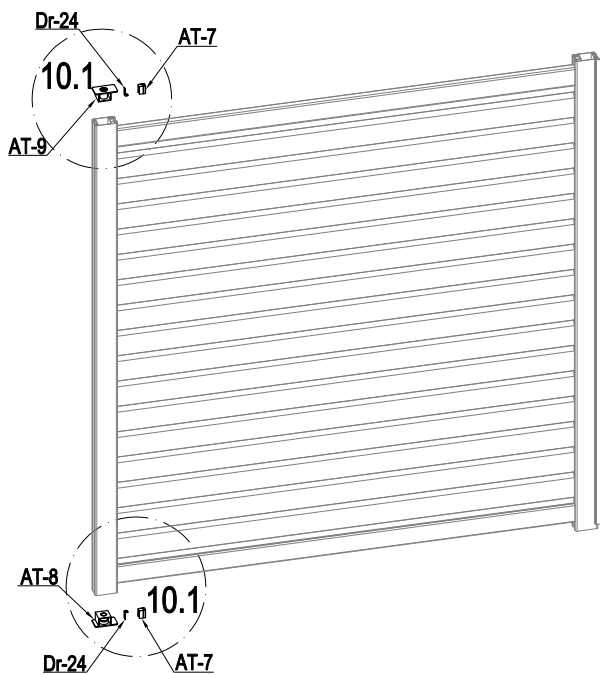

	ST-C11	2
---	--------	---



	ST-C5	1
	Dr-A5c	1
	ST-C7	1



	AT-8	1
	AT-9	1
	Dr-24	2

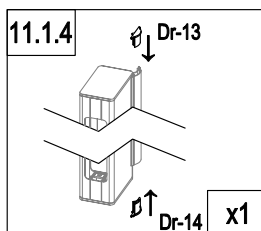
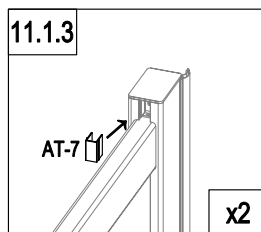
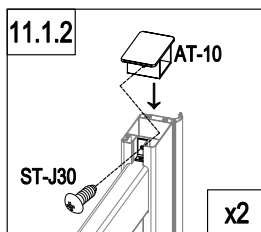
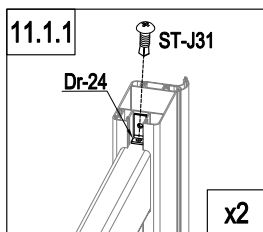
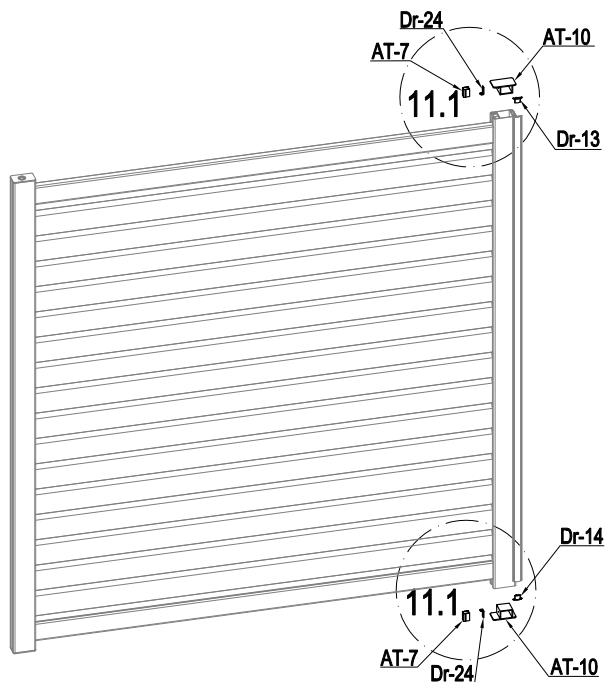

	AT-7	2
	ST-J30	2
	ST-J31	2





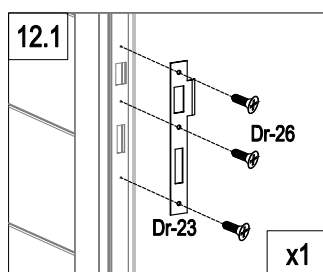
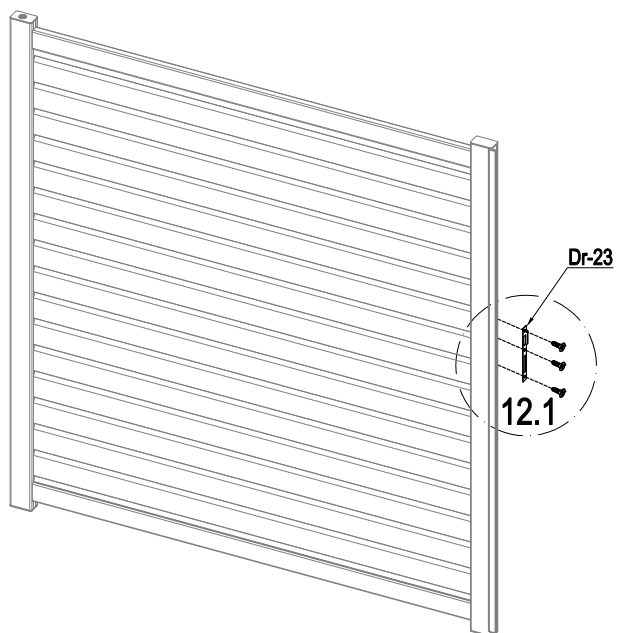

	AT-10	2
	Dr-24	2
	AT-7	2
	Dr-13	1

	Dr-14	1
	ST-J30	2
	ST-J31	2

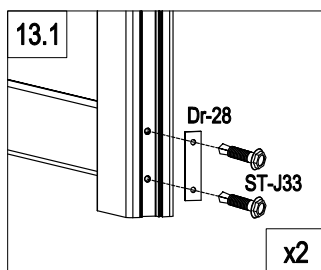
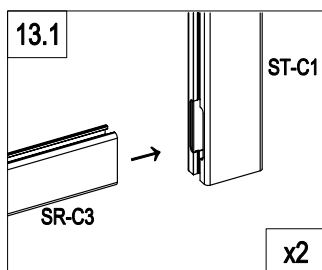
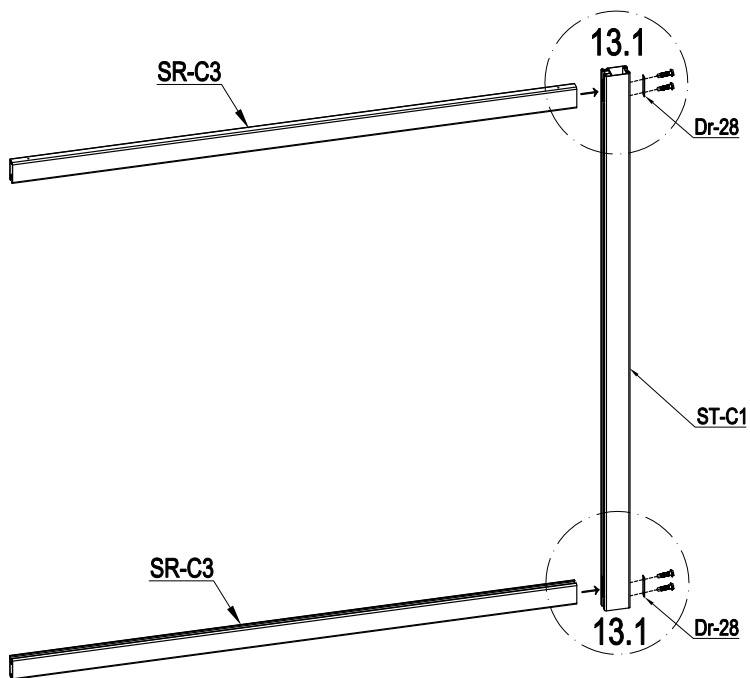

	Dr-23	1
	Dr-26	3



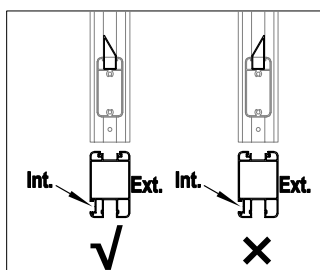
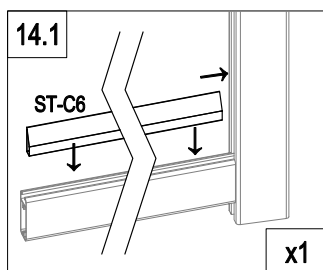
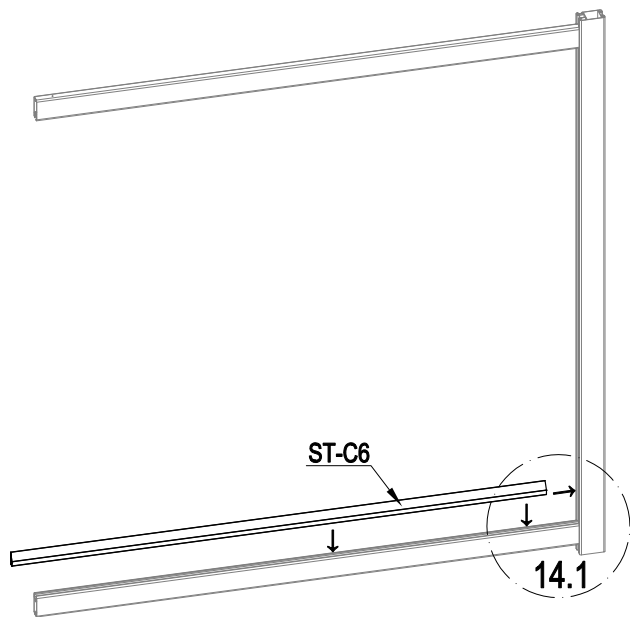

	ST-C1	1
	SR-C3	2
	Dr-28	2
	ST-J33	4



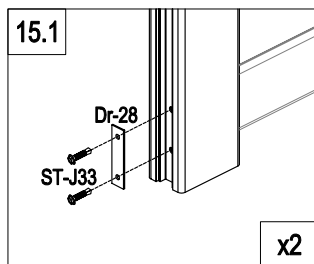
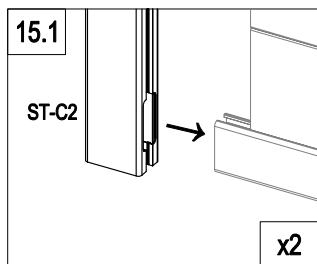
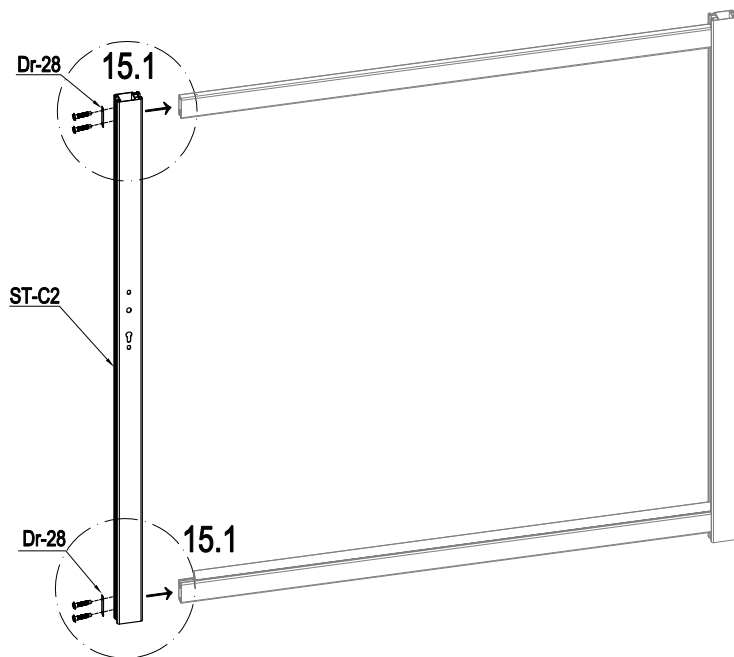

	ST-C6	1
--	-------	---

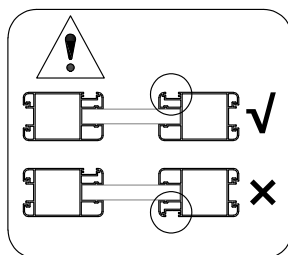

	ST-C2	1
	Dr-28	2
	ST-J33	4

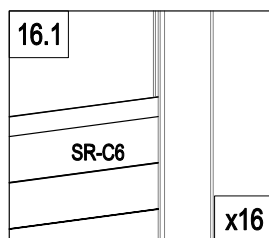
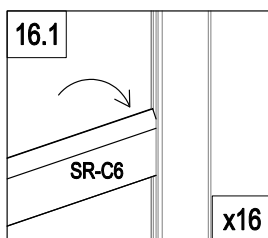
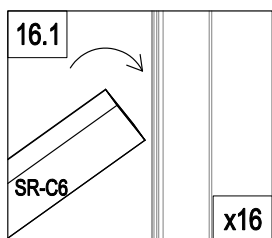
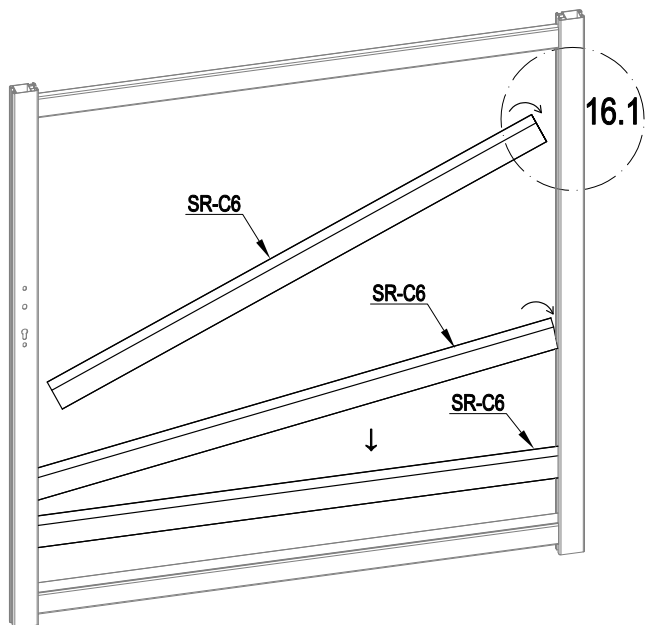



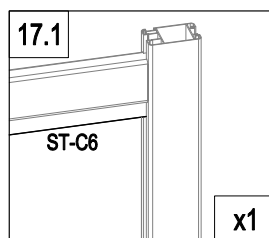
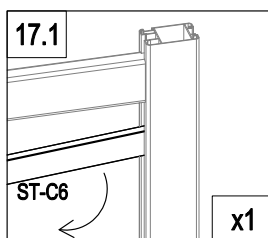
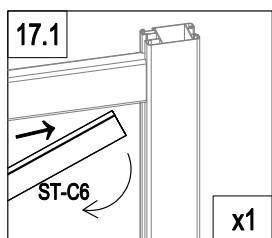
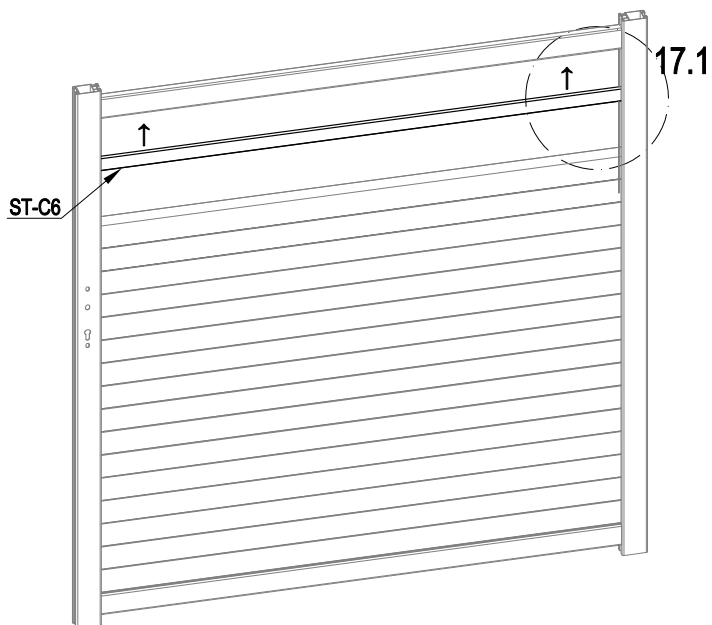

	SR-C6	16
---	-------	----

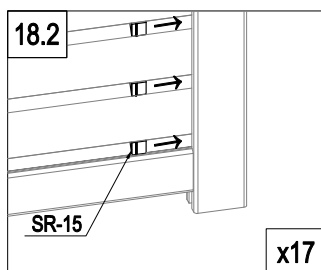
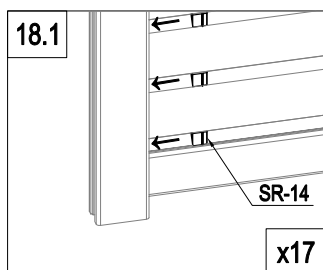
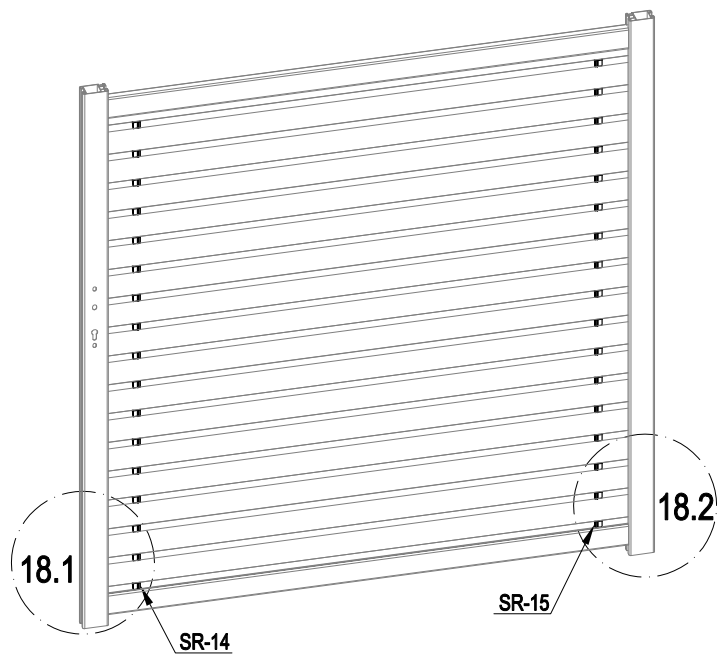

	ST-C6	1
--	-------	---



	SR-14	17
	SR-15	17

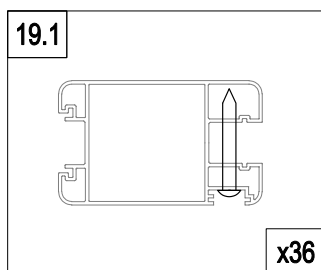
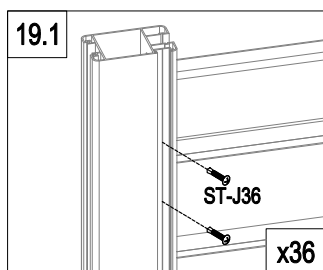
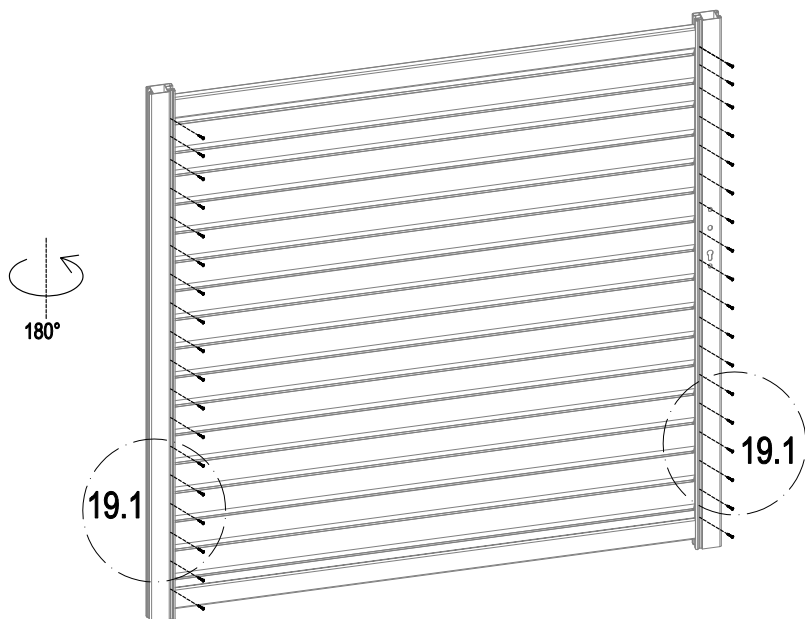

	ST-J36	36
---	--------	----

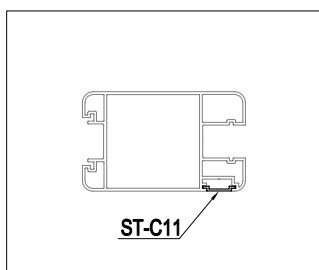
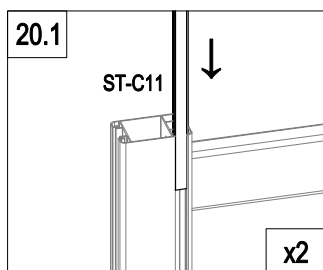
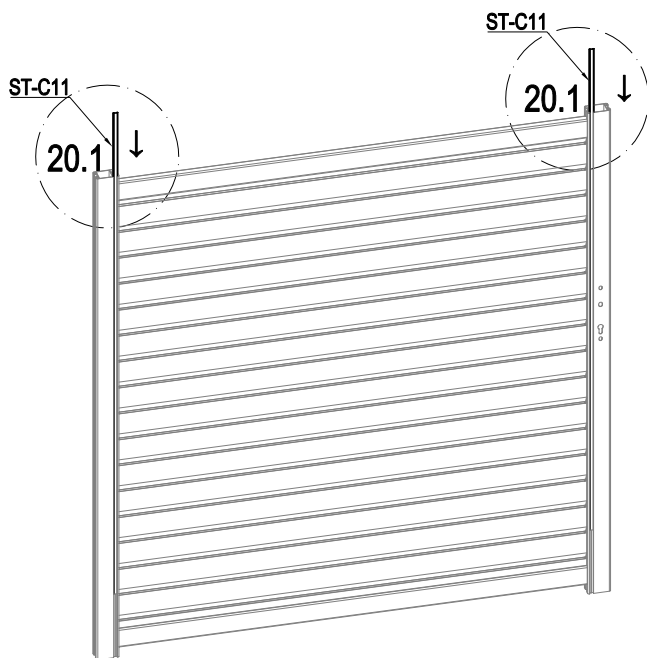

	ST-C11	2
---	--------	---

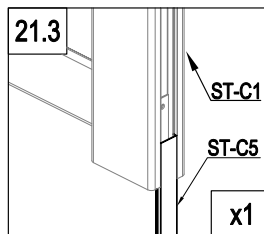
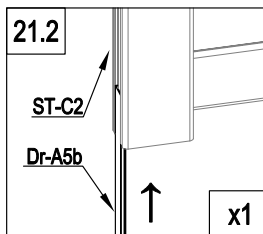
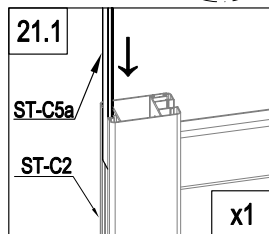
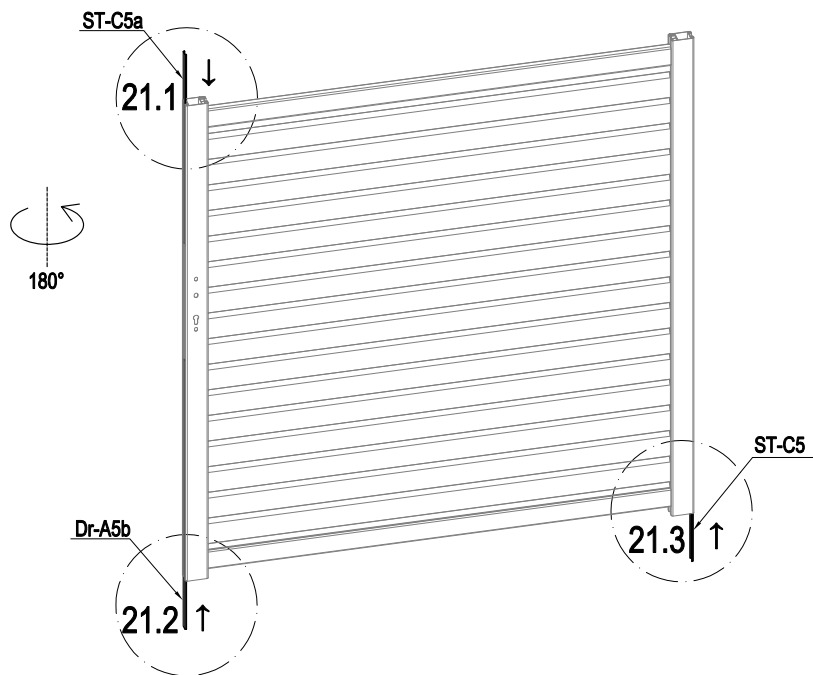

	ST-C5	1
	ST-C5a	1
	Dr-A5b	1

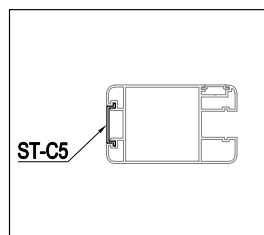

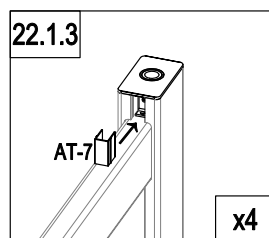
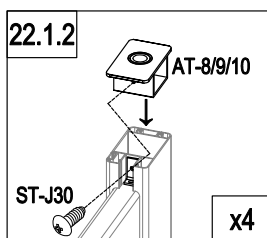
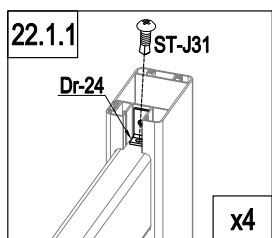
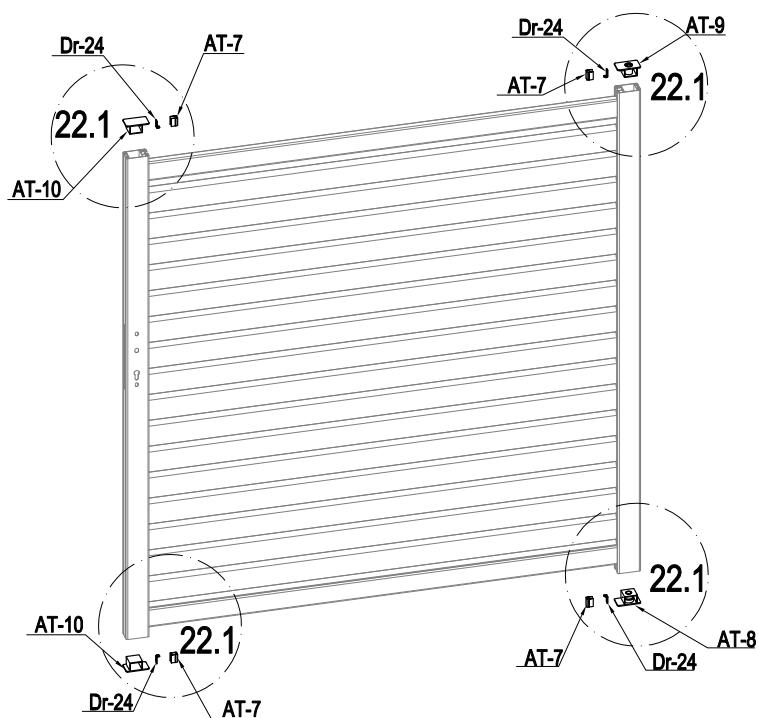





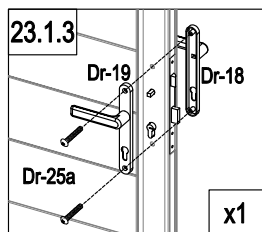
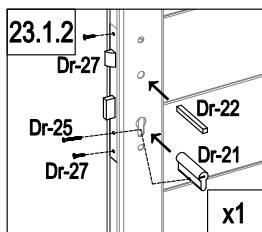
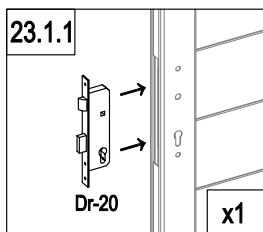
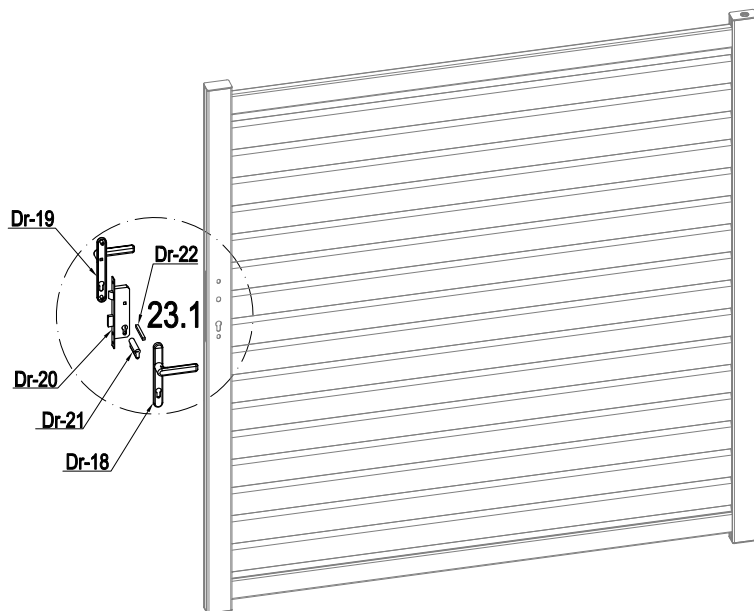



	AT-8	1
	AT-9	1
	AT-10	2
	Dr-24	4

	AT-7	4
	ST-J30	4
	ST-J31	4



	Dr-20	1
	Dr-21	1
	Dr-22	1
	Dr-25	1

	Dr-18	1
	Dr-19	1
	Dr-25a	2
	Dr-27	2

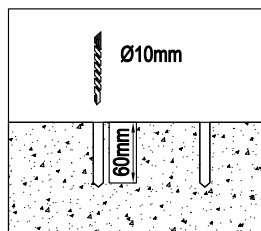
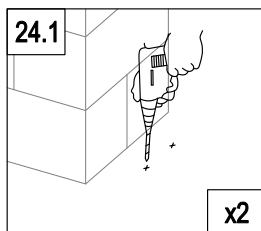
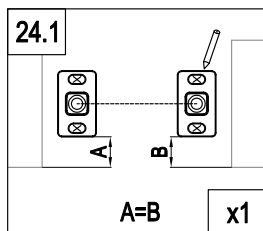
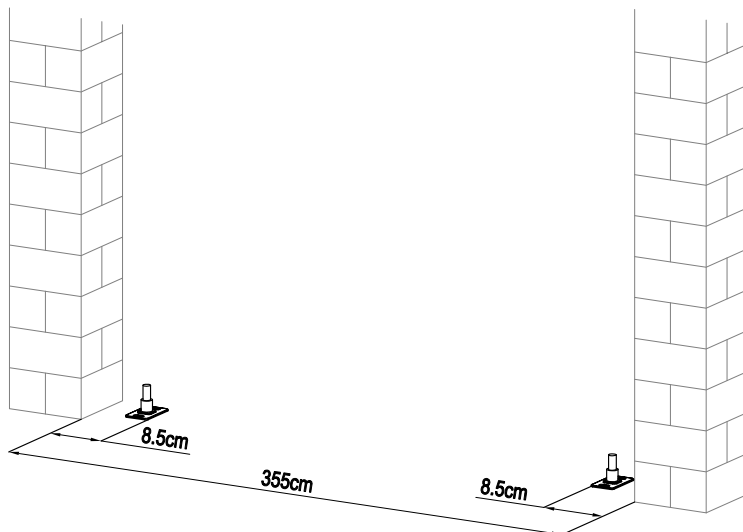

- !** **EN:** The installation of your gate affects the opening angle of the operator. Refer to your motor manual
FR: L'installation de votre portail impacte l'angle d'ouverture de la motorisation. Référez vous à la notice de votre moteur
DE: Der Einbau Ihres Tores beeinflusst den Öffnungswinkel des Antriebs. Siehe Ihr Motorhandbuch
ES: La instalación de su puerta influye en el ángulo de apertura del automatismo. Consulte el manual de su motor
PT: A instalação do seu portão afecta o ângulo de abertura do acionamento. Consultar o manual do motor
IT: L'installazione del cancello influisce sull'angolo di apertura dell'operatore. Consultare il manuale del motore
NL: De installatie van je poort beïnvloedt de openingshoek van de aandrijving. Raadpleeg de handleiding van uw motor
PL: Sposób montażu bramy wpływa na kąt otwarcia napędu. Więcej informacji można znaleźć w instrukcji obsługi silnika

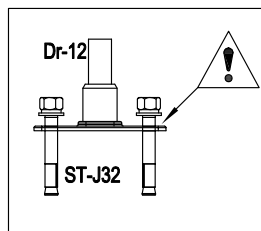
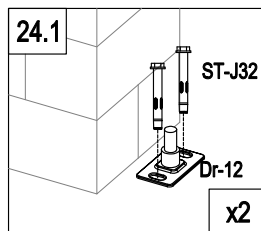

	Dr-12	1
	ST-J32	2

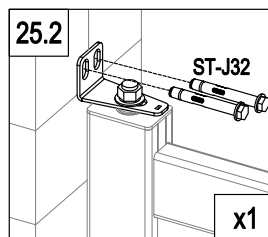
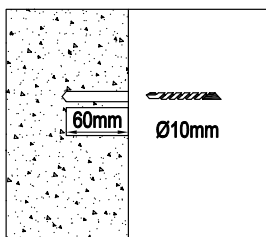
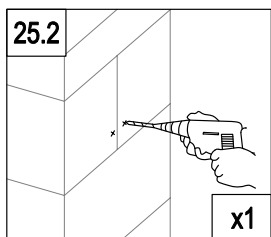
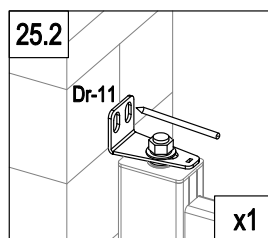
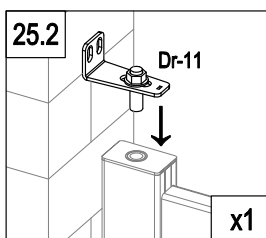
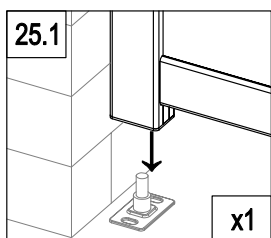
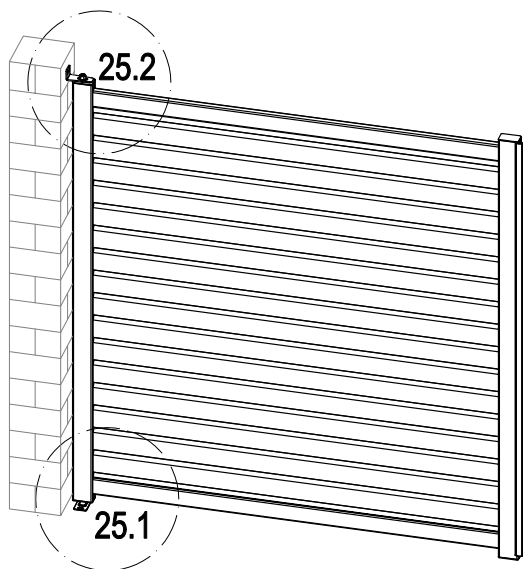



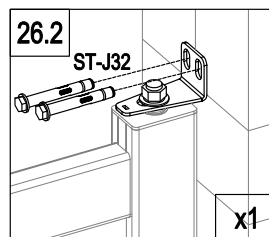
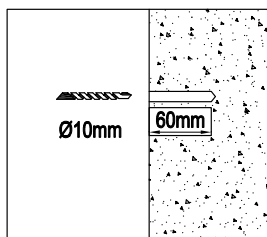
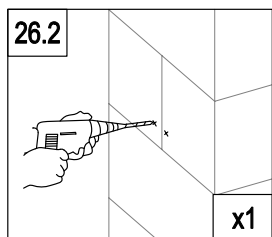
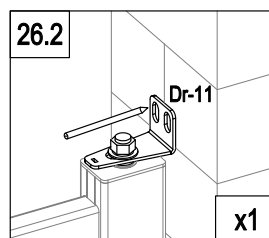
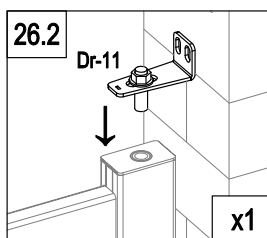
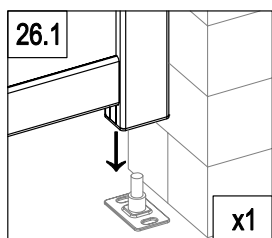
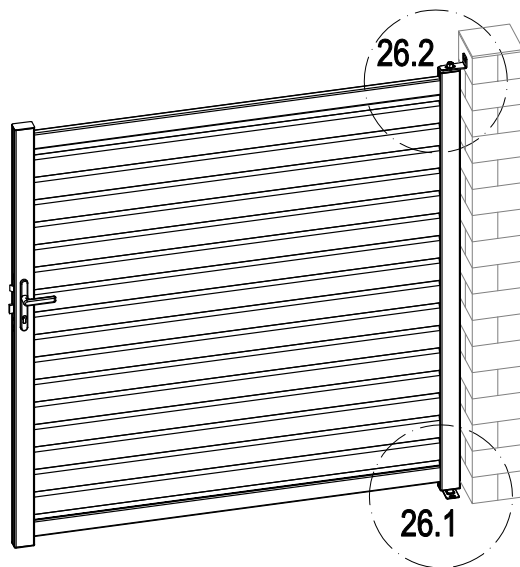

	Dr-11	1		ST-J32	2
---	-------	---	---	--------	---



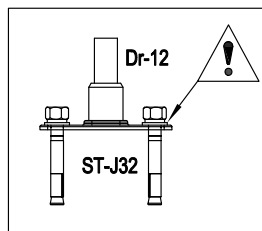
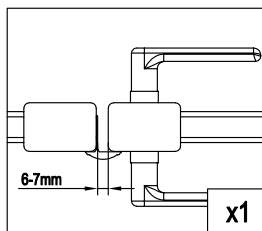
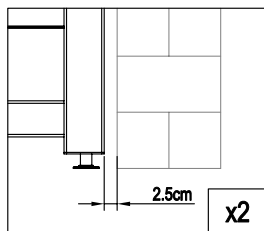
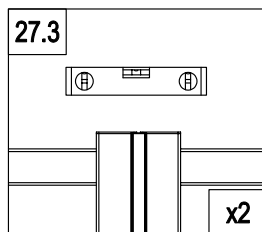
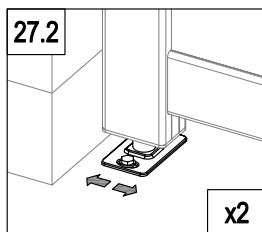
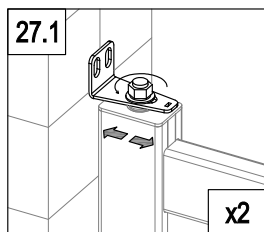
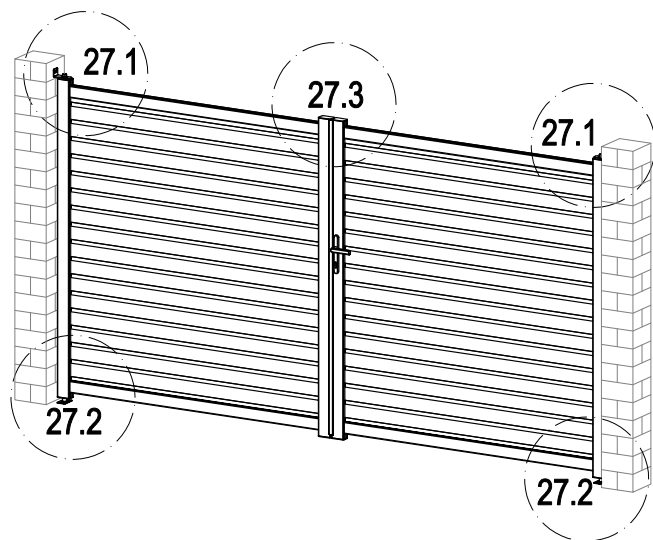

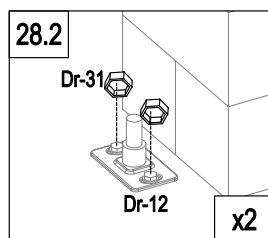
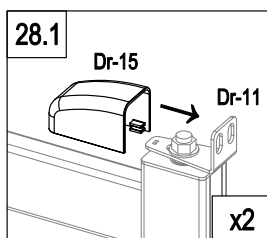
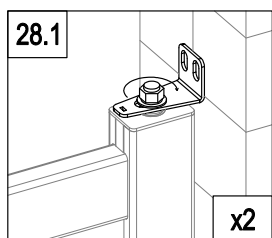
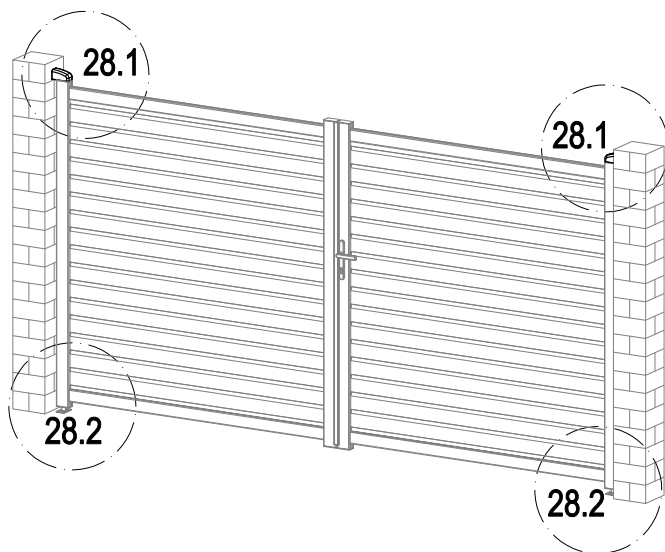

	Dr-11	1		ST-J32	2
--	-------	---	--	--------	---



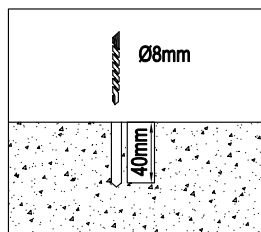
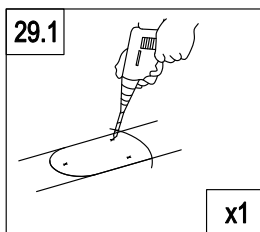
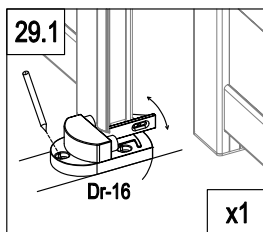
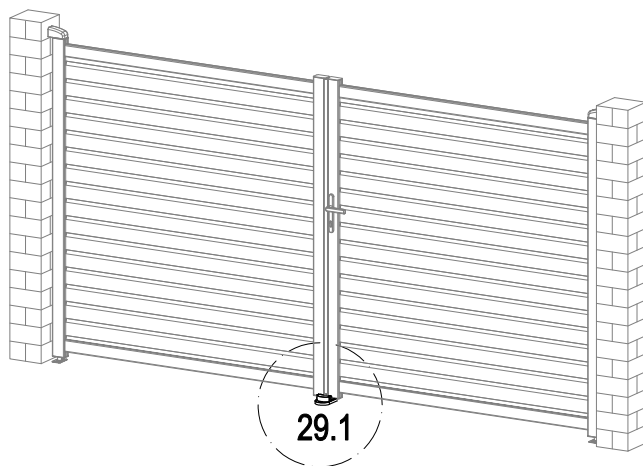



	Dr-15	2
	Dr-31	4

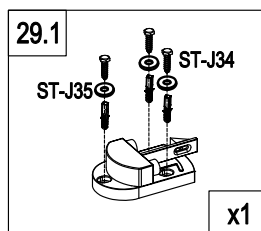

	Dr-16	1
	ST-J34	3
	ST-J35	3

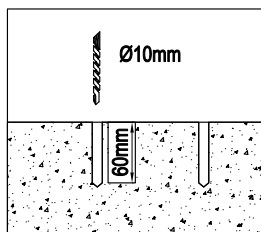
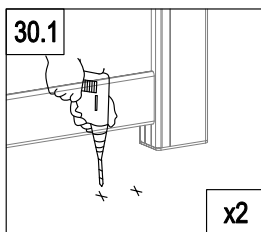
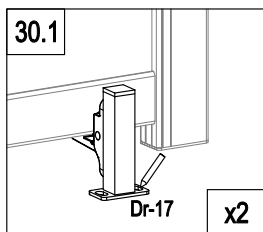
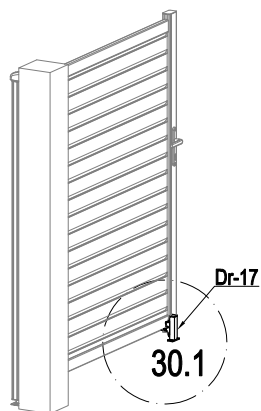
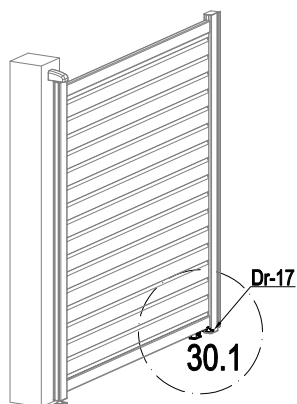



	ST-J32	4
	Dr-17	2

