

CASANOVO

ART300C140

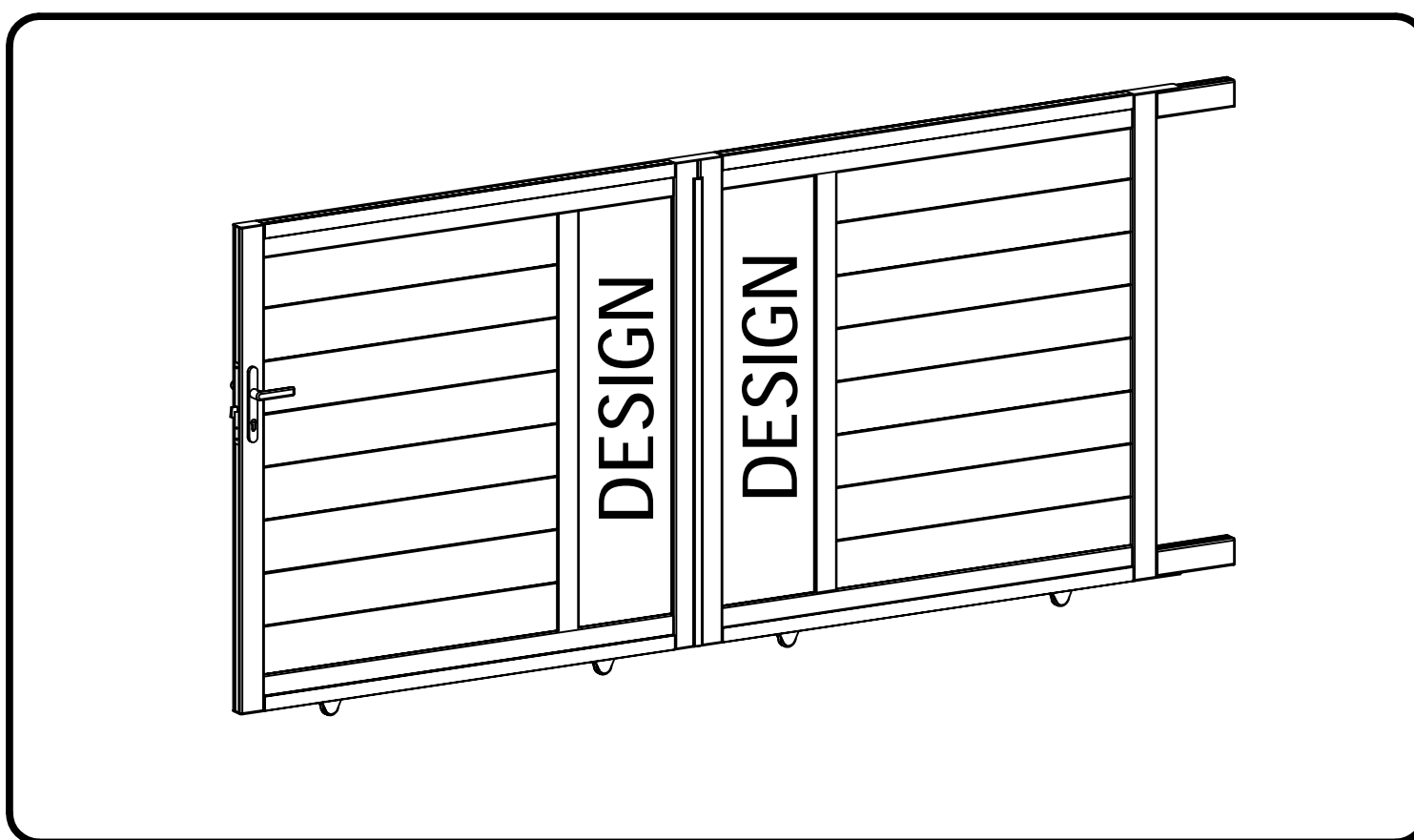

7-8H



x2

COM-000241	[x1]
COM-000242	[x1]
COM-000243	[x1]
COM-000*DESIGN*	[x1]

*Selon modèle

FR

EN

ES

DE

IT

NL

PL



Ext.

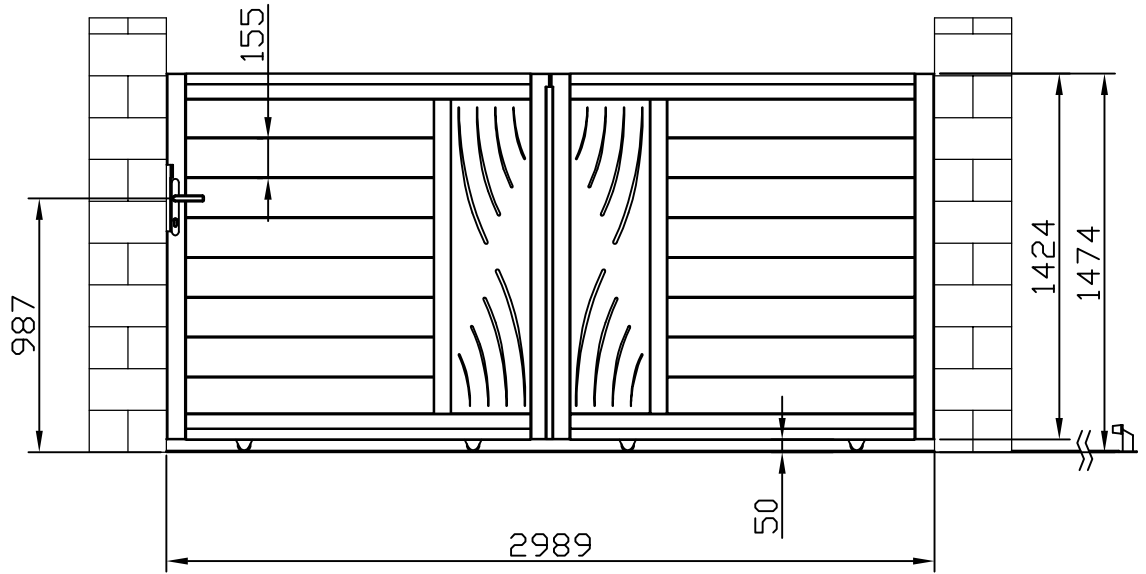

Int.

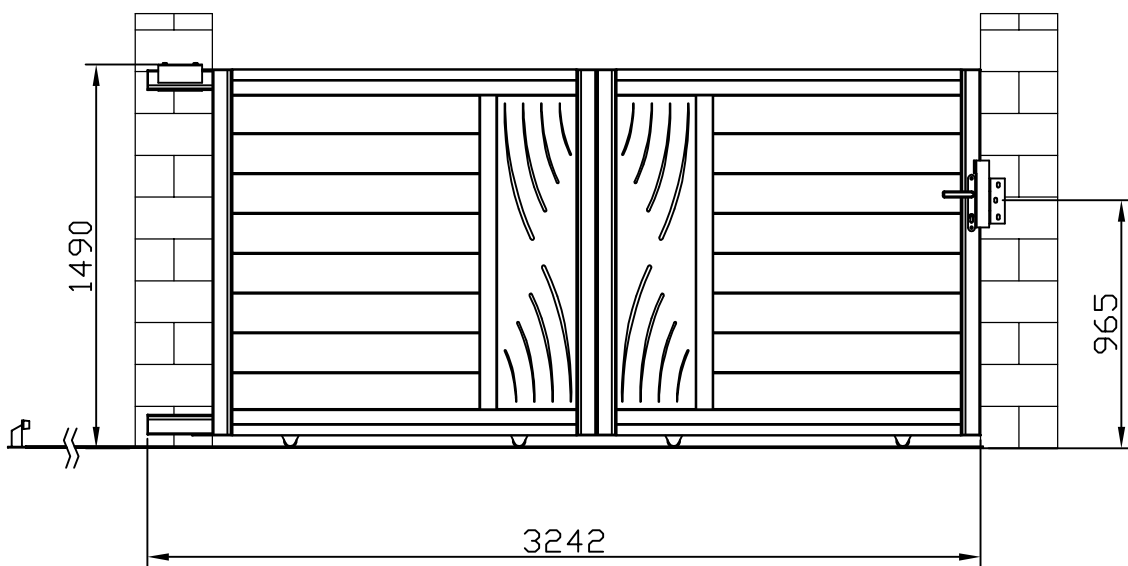

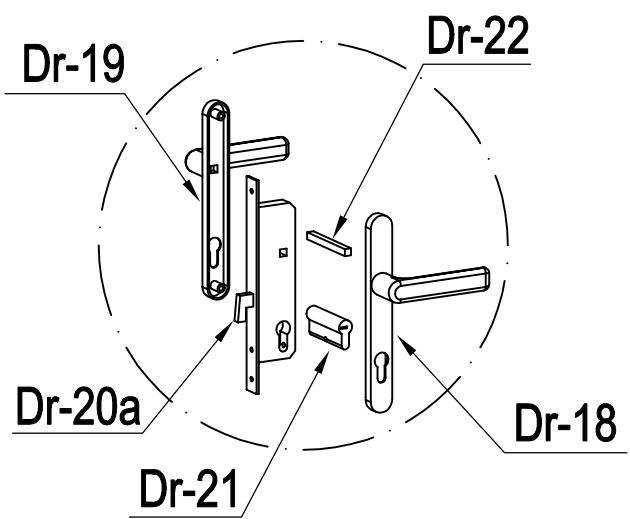
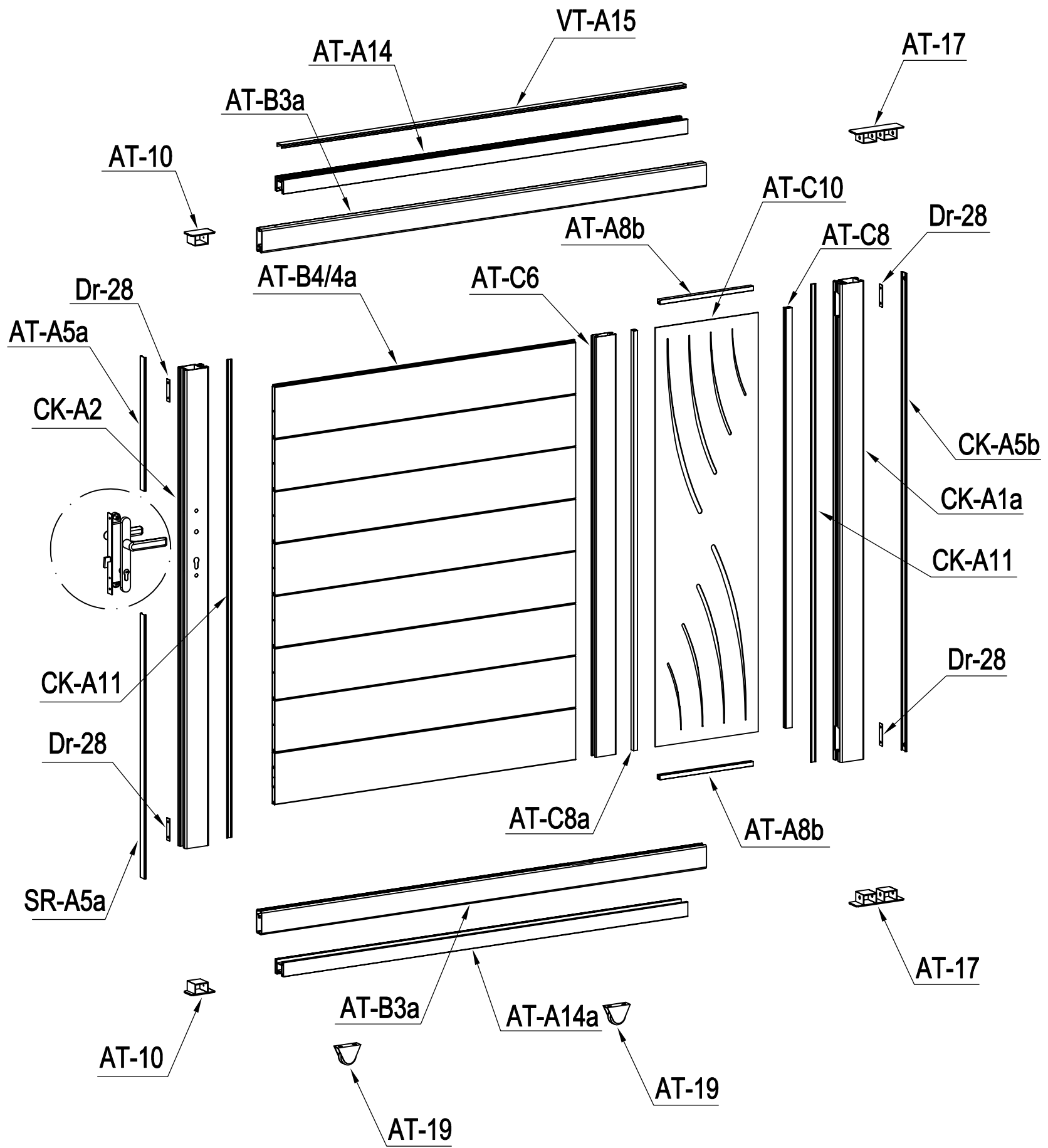

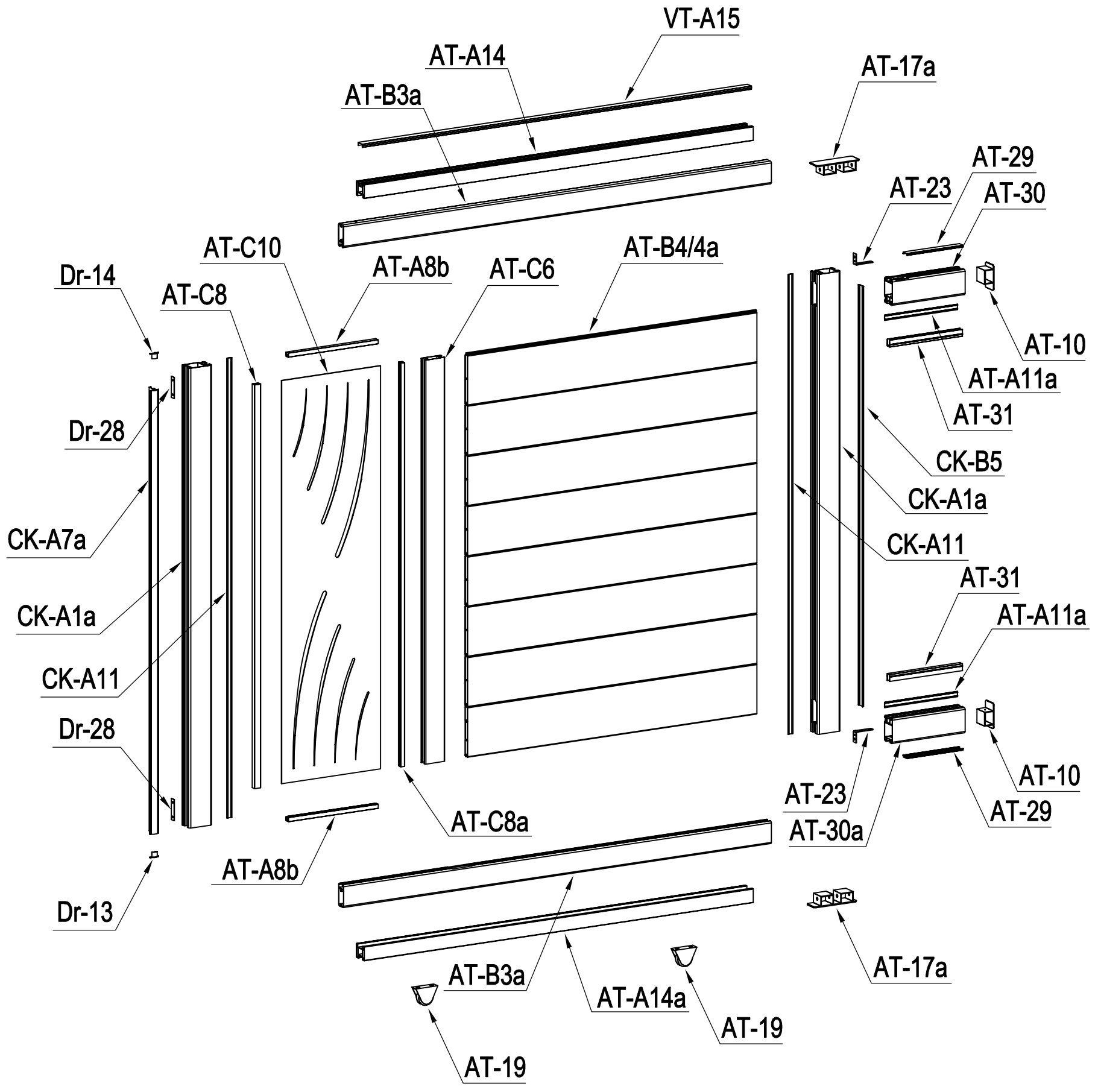

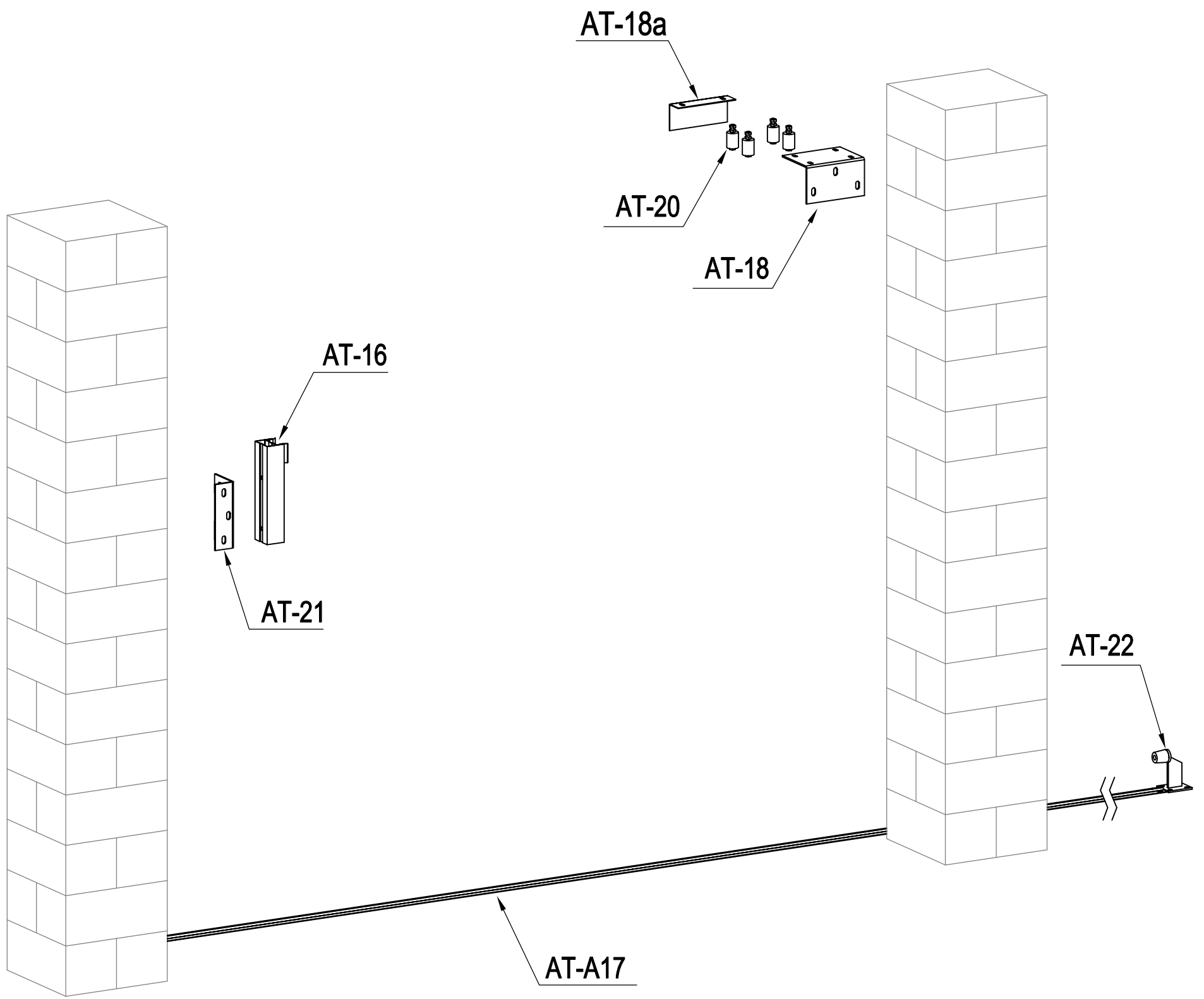



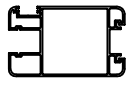



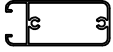

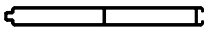



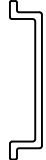





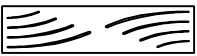

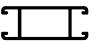





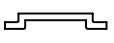















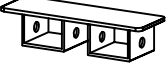
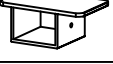

PART LIST

IMAGE	NO.	L.(mm)	QTY	IMAGE	NO.	L.(mm)	QTY
	CK-A1a	1418	3		Dr-14		1
	CK-A2	1418	1		AT-18		1
	AT-30	250	1		AT-18a		1
	AT-30a	250	1		AT-19		4
	AT-B3a	1471	4		AT-20		4
	AT-B4	995	14		AT-21		1
	AT-B4a	995	2		AT-22		1
	CK-B5	1293	1		AT-23		2
	AT-A5a	395.5	1		Dr-18		1
	SR-A5a	782	1		Dr-19		1
	CK-A5b	1418	1		Dr-20a		1
	AT-29	193	2		Dr-21		1
	AT-C10	1243	2		Dr-22		1
	AT-C6	1246	2		Dr-25		1
	AT-C8	1245	2		Dr-25a		2
	AT-C8a	1245	2		Dr-27		2
	AT-A8b	308.5	4		AT-U30		4
	CK-A11	1418	4		AT-U31		10
	AT-A11a	250	2		AT-U32		28
	AT-31	250	2		AT-U33		4
	CK-A7a	1365	1		AT-U34		56
	AT-A14	1338	2		AT-U35		6
	AT-A14a	1338	2		AT-U36		2
	VT-A15	1337	2		AT-U37		8
	AT-16	260	1		AT-U38		40
	AT-A17	1212	5		AT-U39		8
	AT-17		2		Dr-28		6
	AT-17a		2				
	AT-10		4				
	Dr-13		1				

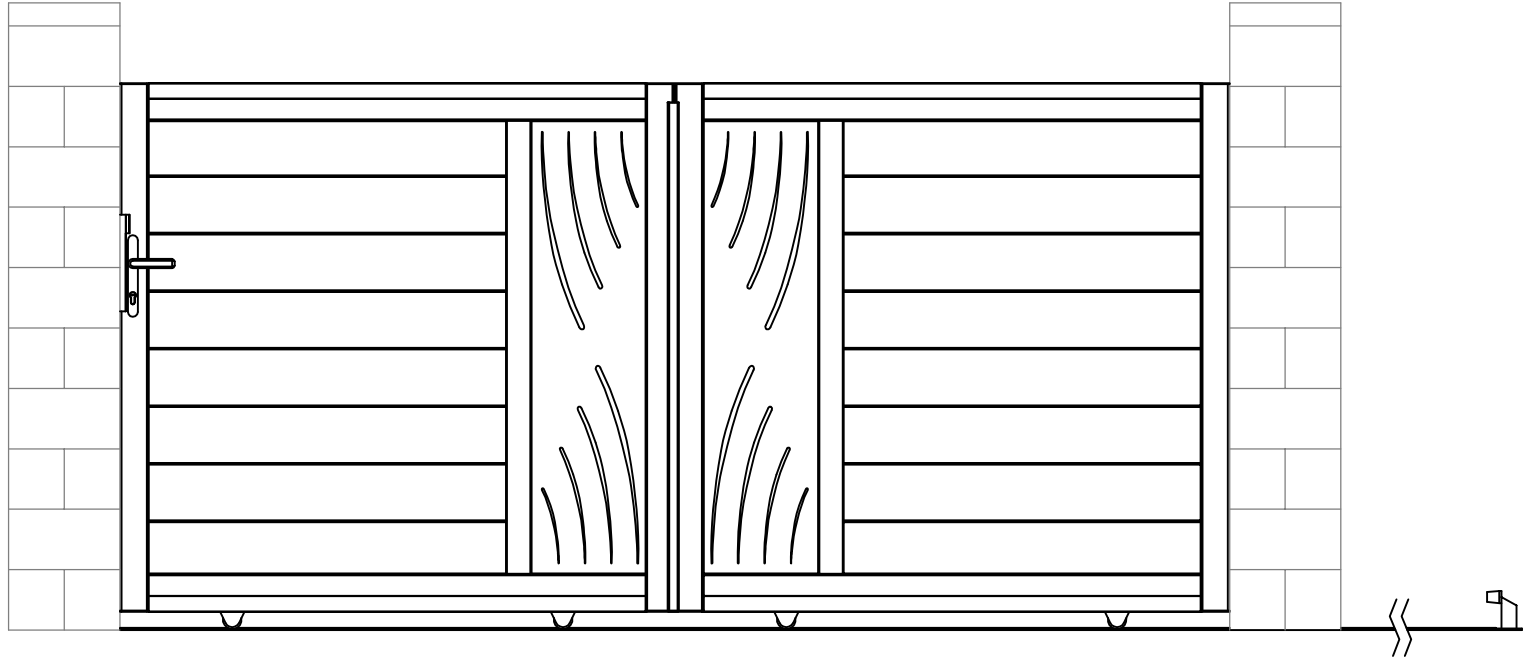

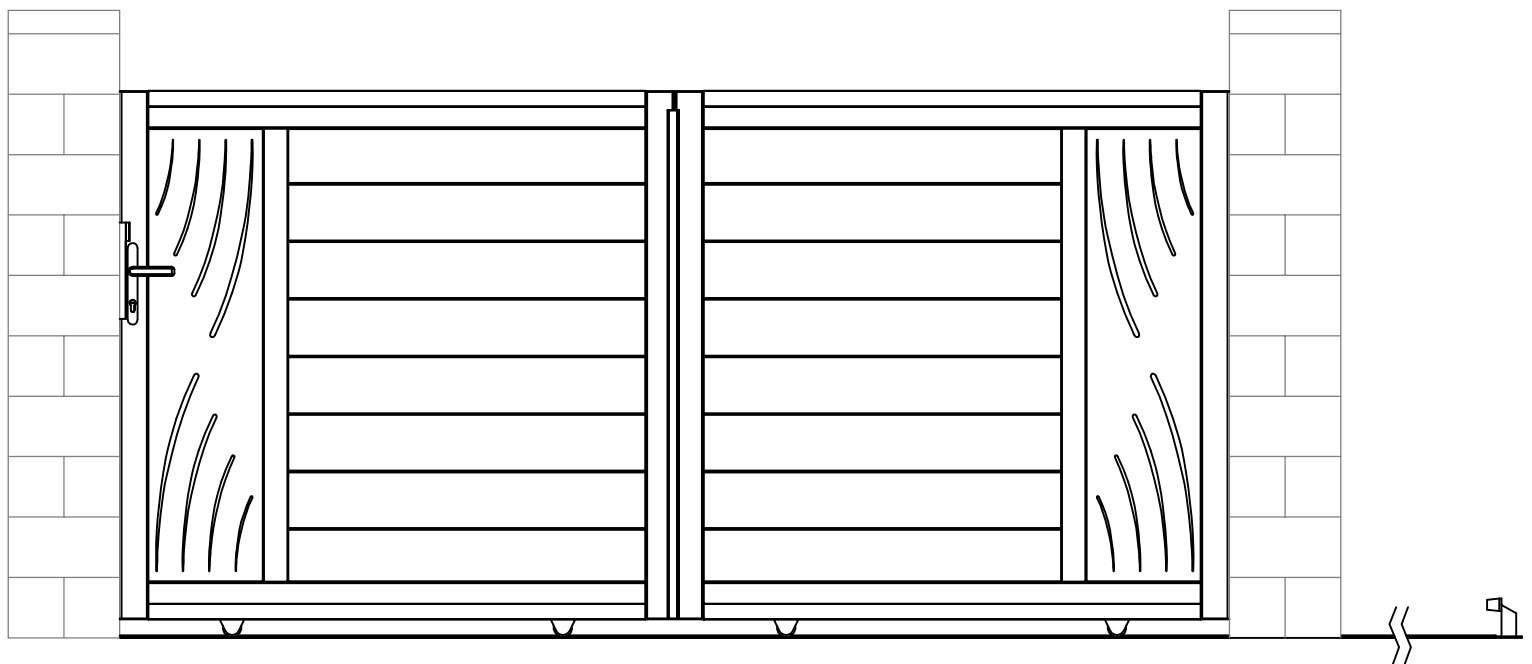

A : P1~25

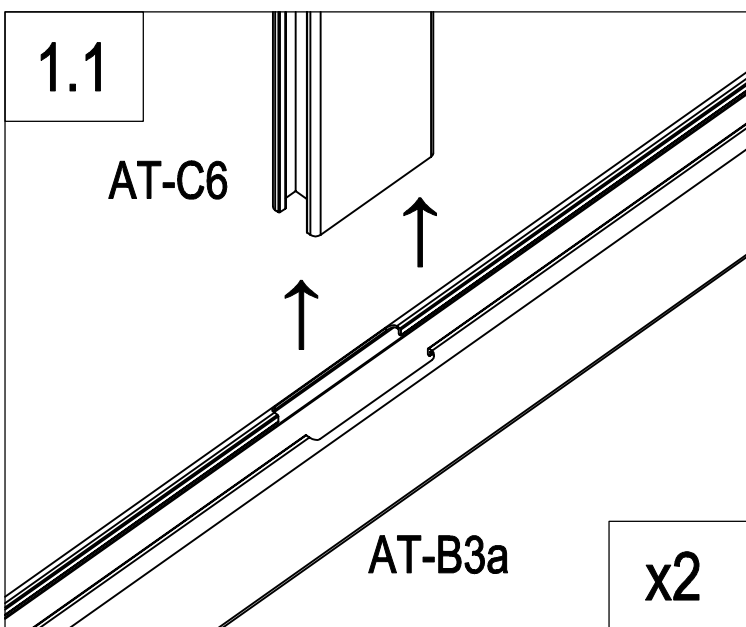
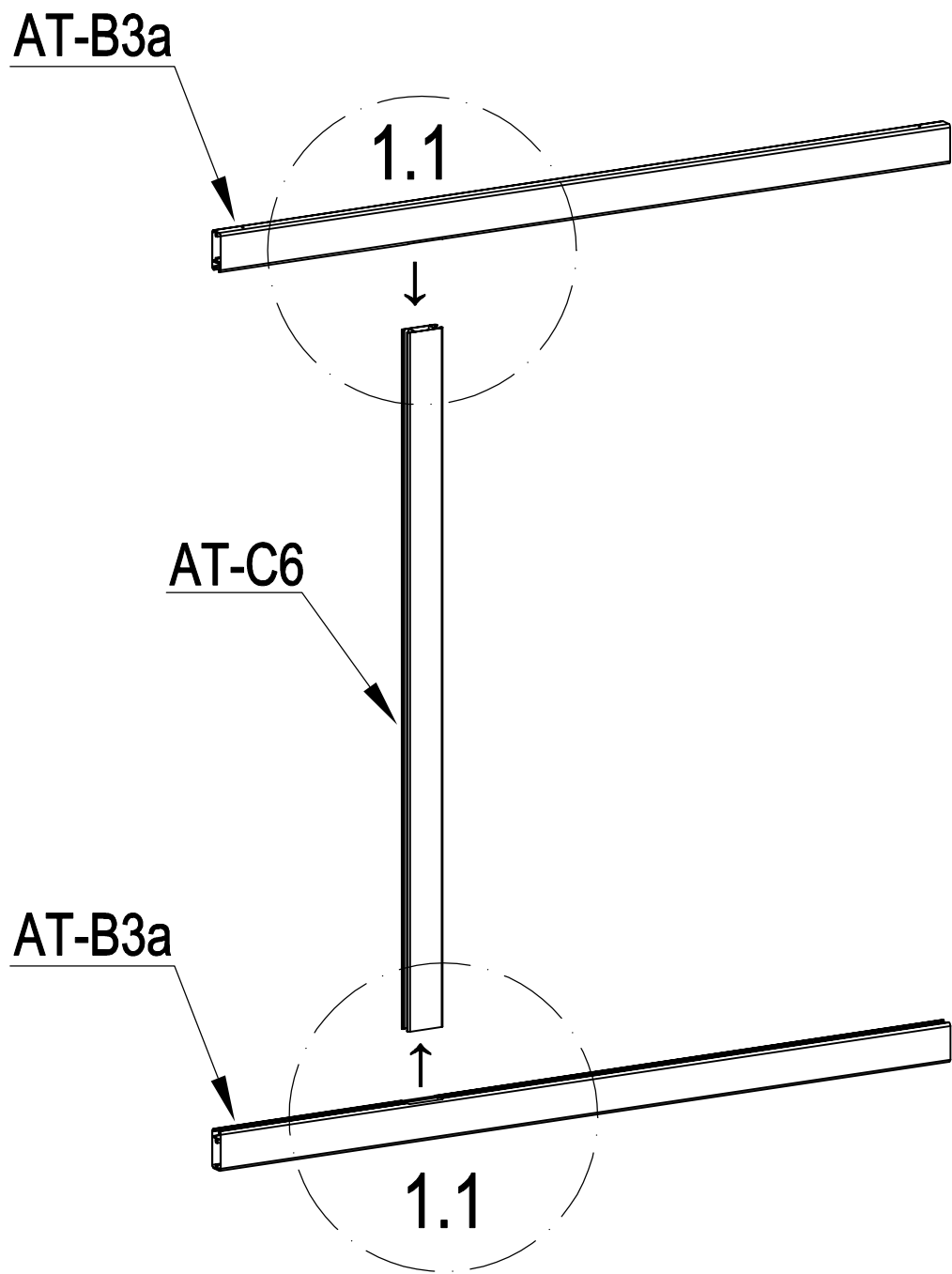

B : P26~50

A



	AT-C6	1
	AT-B3a	2



EN :you can flip and switch the direction of this plate to personalize your gate
 FR: vous pouvez retourner et changer la direction de cette plaque pour personnaliser votre portail
 DE: Sie können dieses Schild umdrehen und die Richtung wechseln, um Ihr Tor zu personalisieren.
 ES: puedes girar y cambiar la dirección de esta placa para personalizar tu puerta
 PT: pode virar e mudar a direção desta placa para personalizar o seu portão
 IT: potete capovolgere e cambiare la direzione di questa piastra per personalizzare il vostro cancello
 NL: u kunt de richting van deze plaat omdraaien en veranderen om uw poort te verpersoonlijken...
 PL: można obrócić i przełączyć kierunek tej płyty, aby spersonalizować bramę.

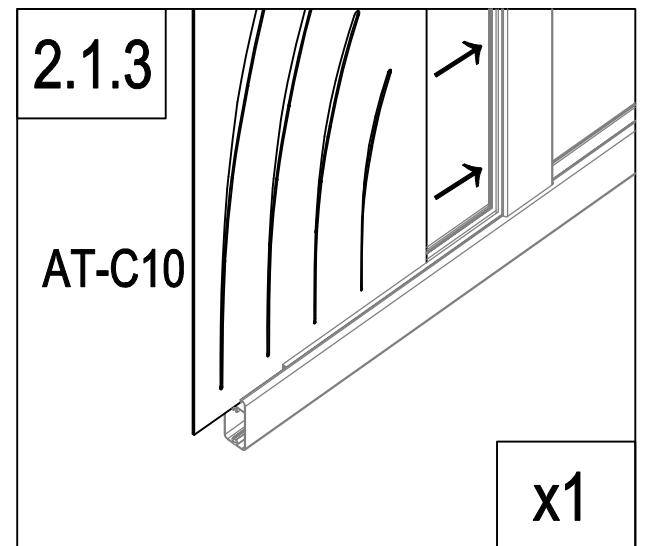
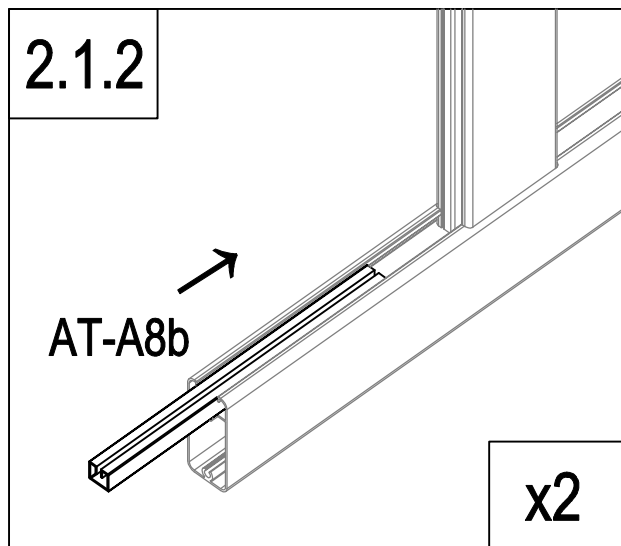
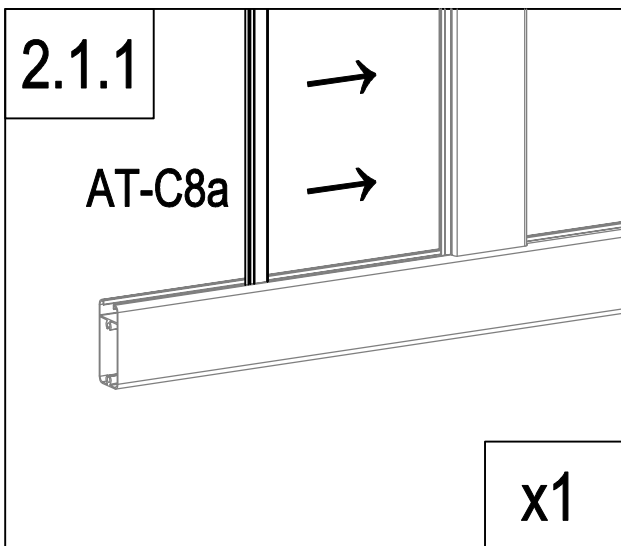
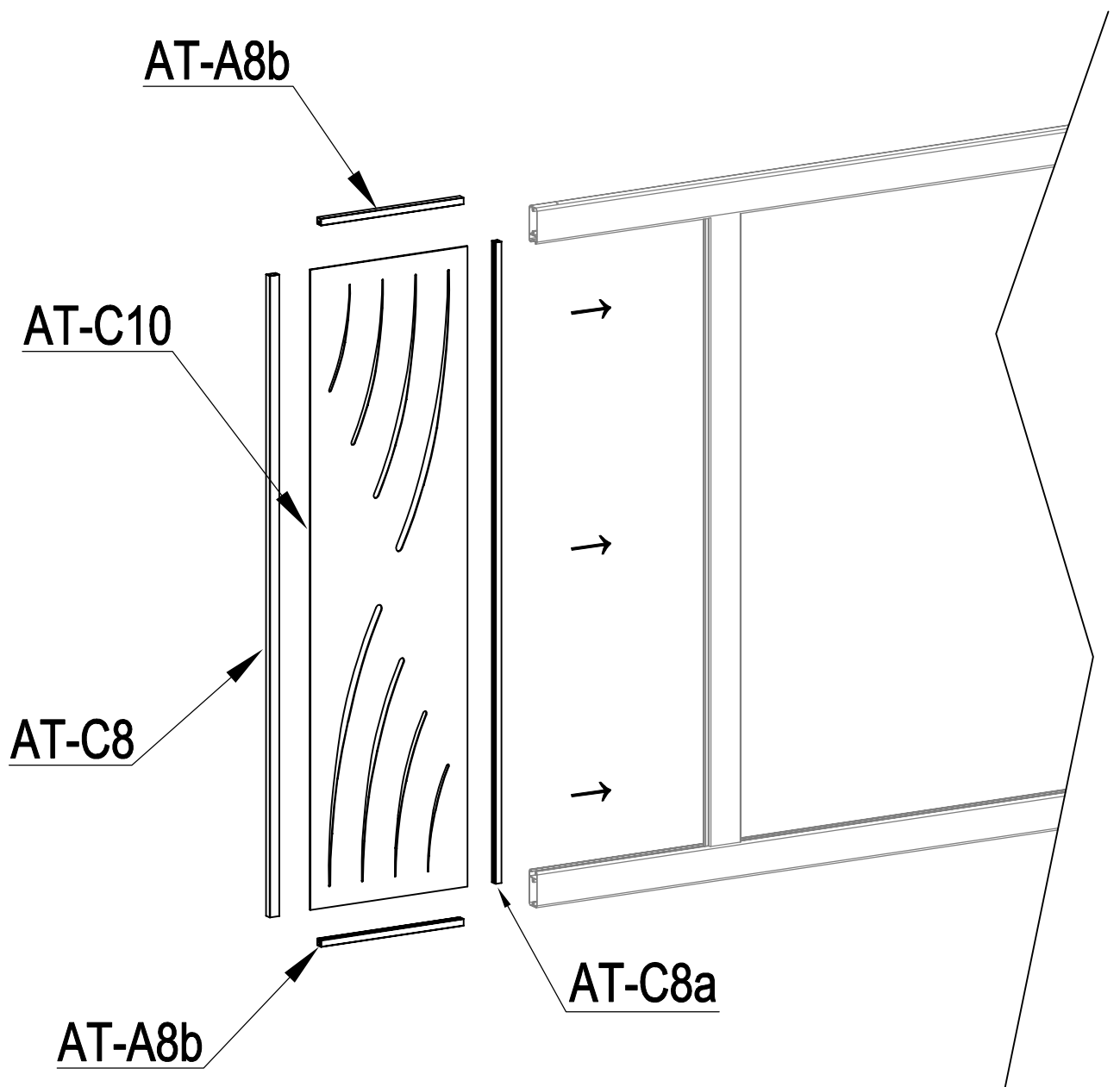

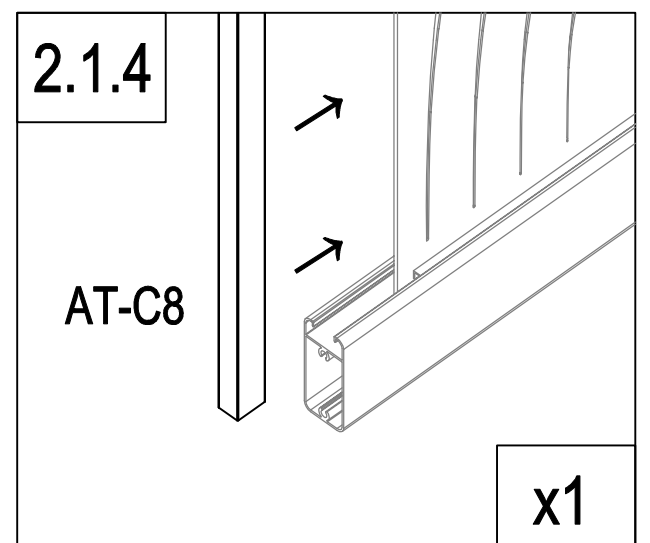

	AT-C8a	1
	AT-A8b	2
	AT-C10	1
	AT-C8	1

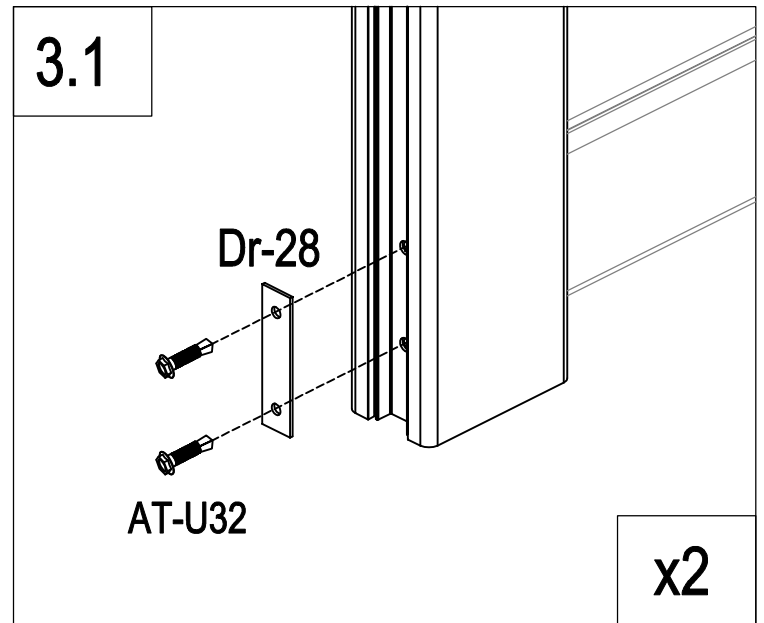
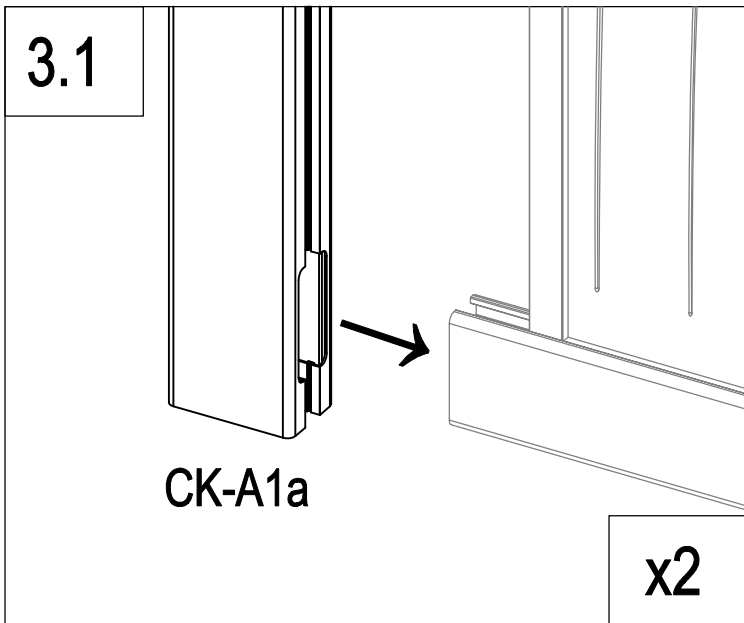
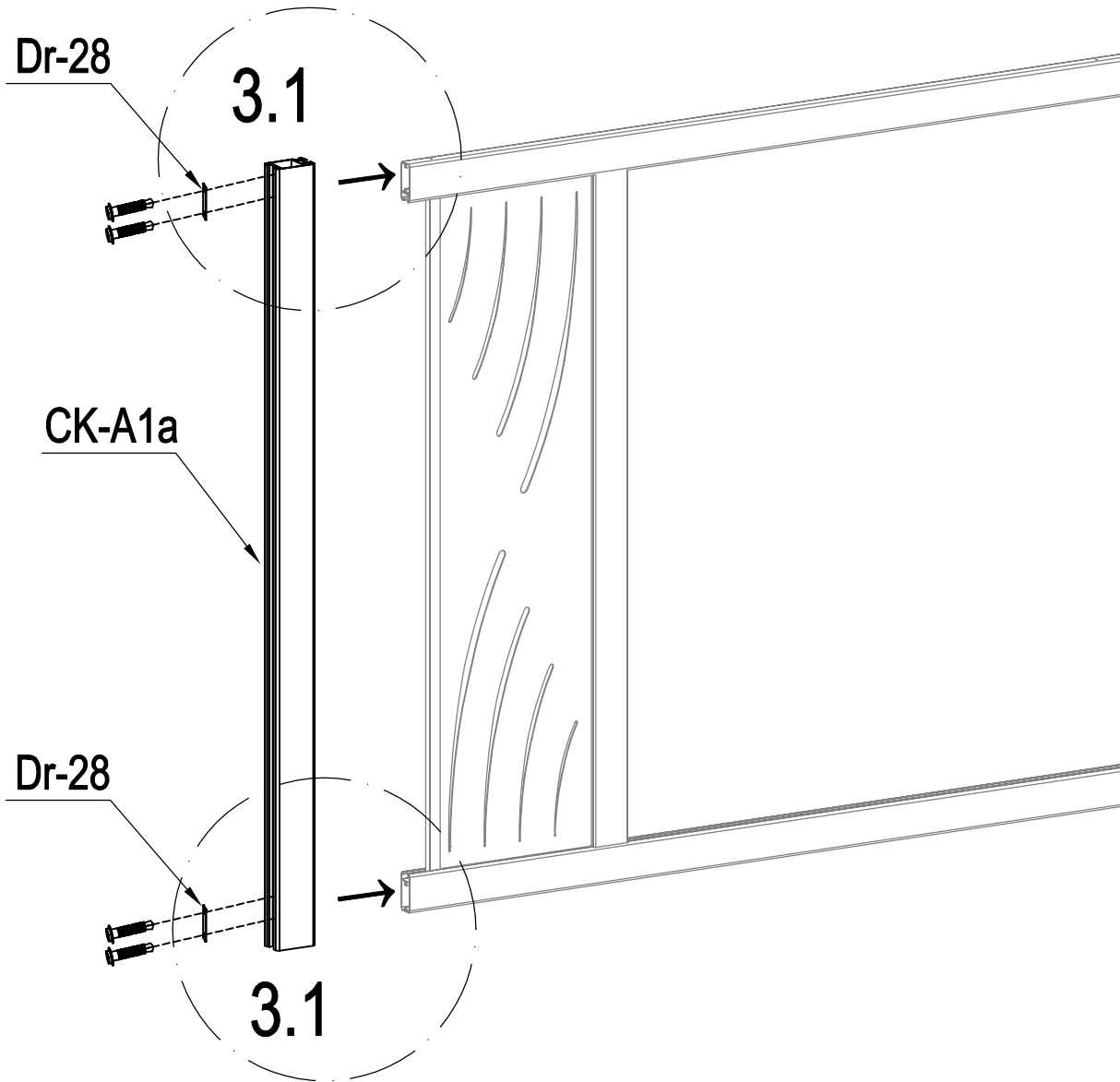

A

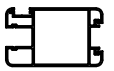

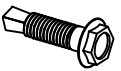
	CK-A1a	1
	Dr-28	2
	AT-U32	4

A

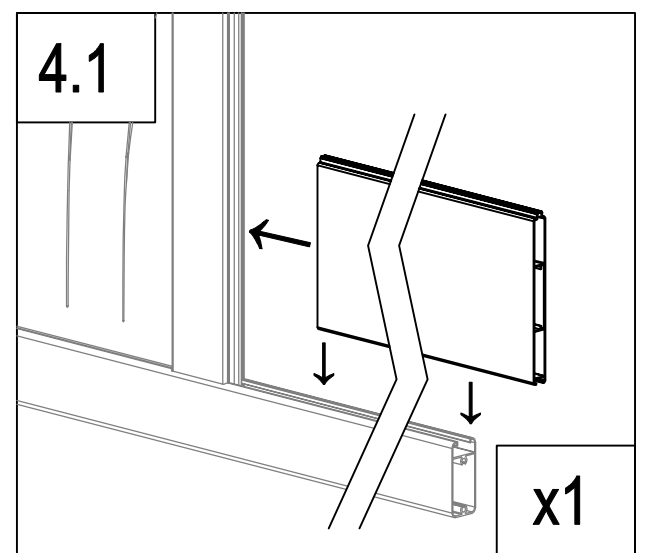
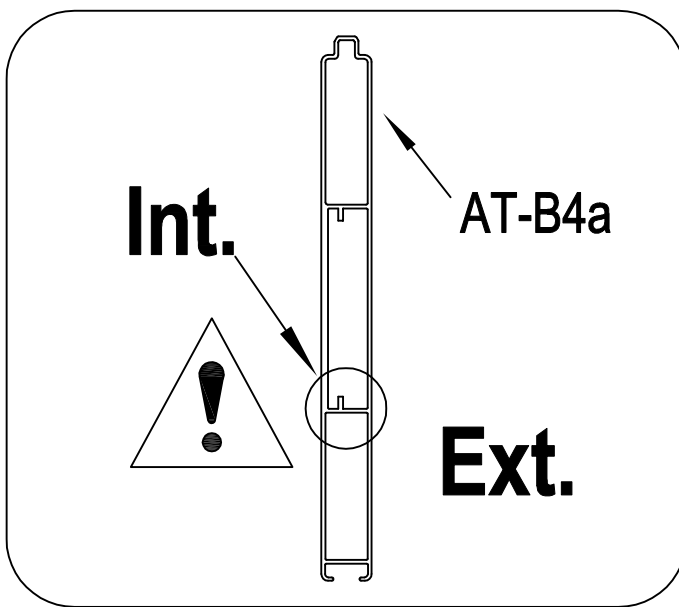
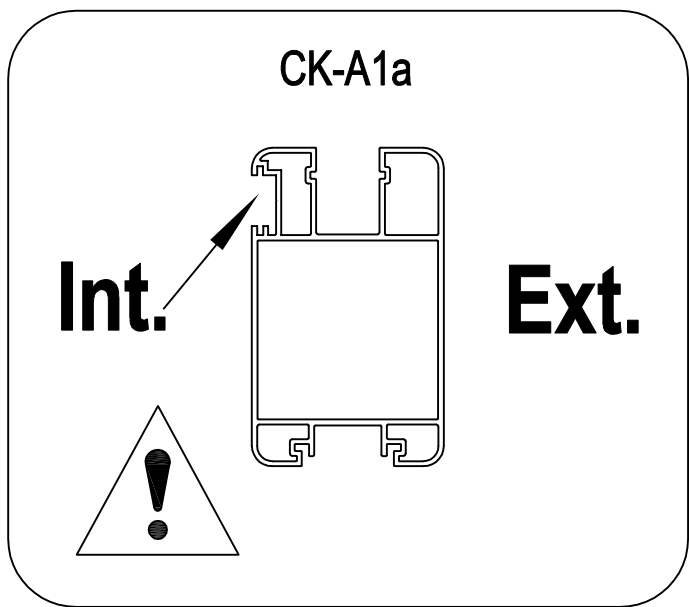
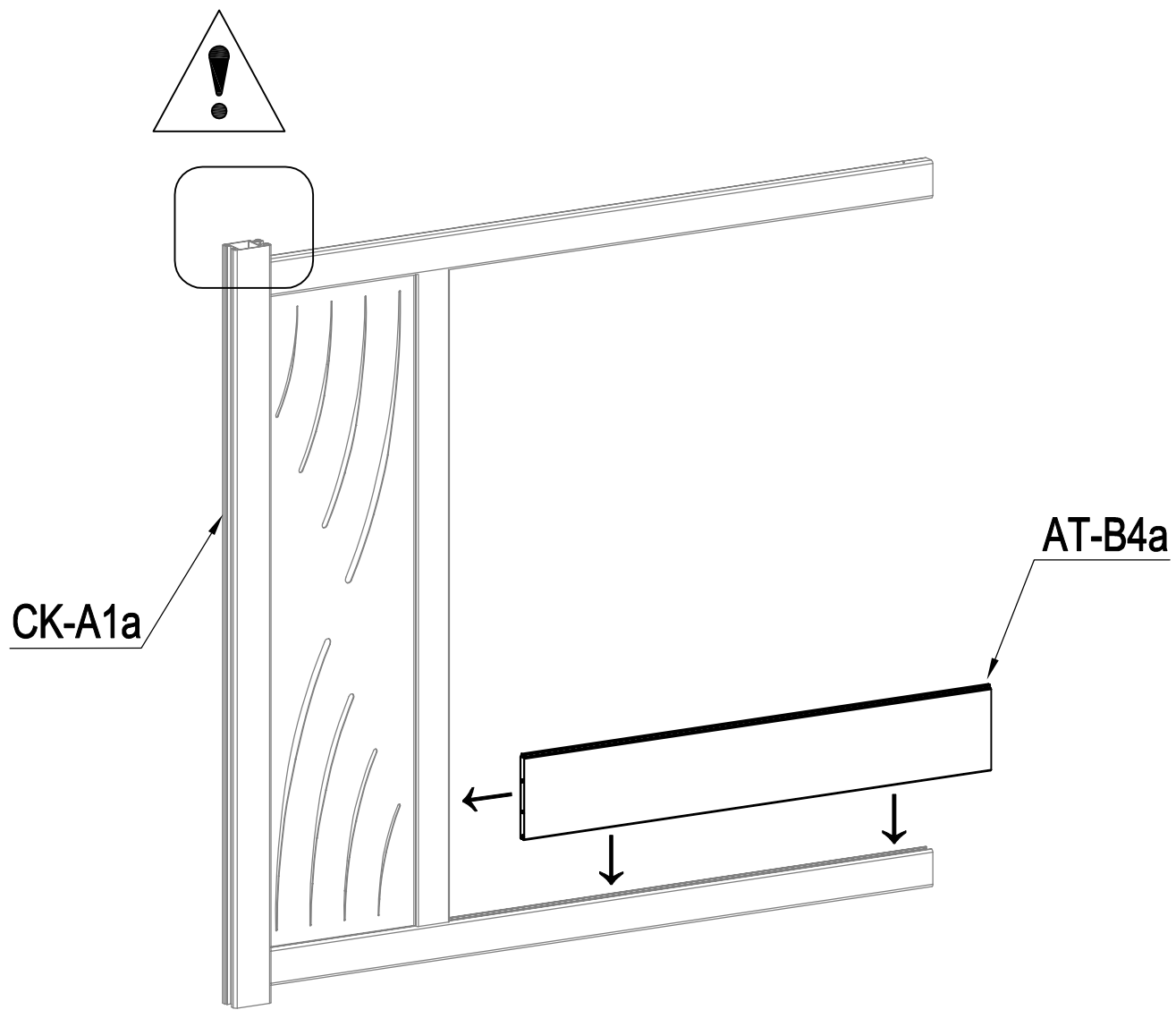

	AT-B4a	1
---	--------	---

A

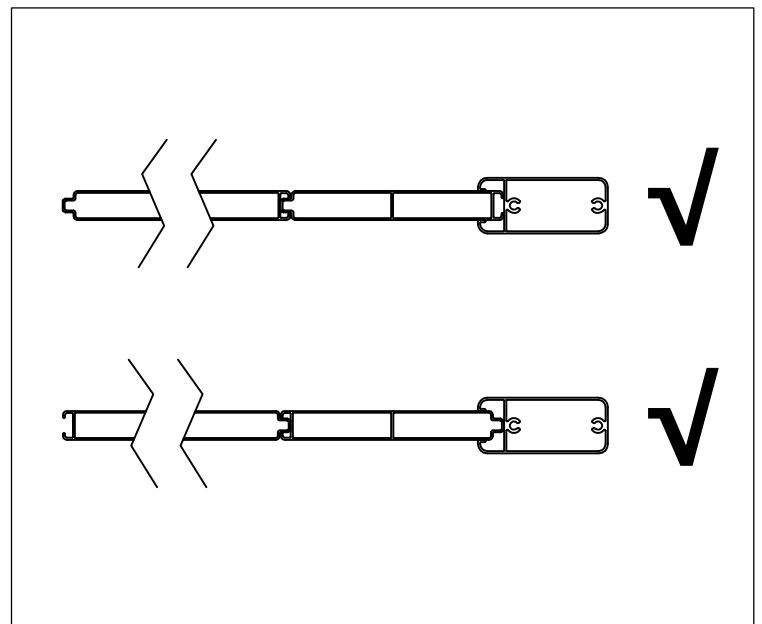
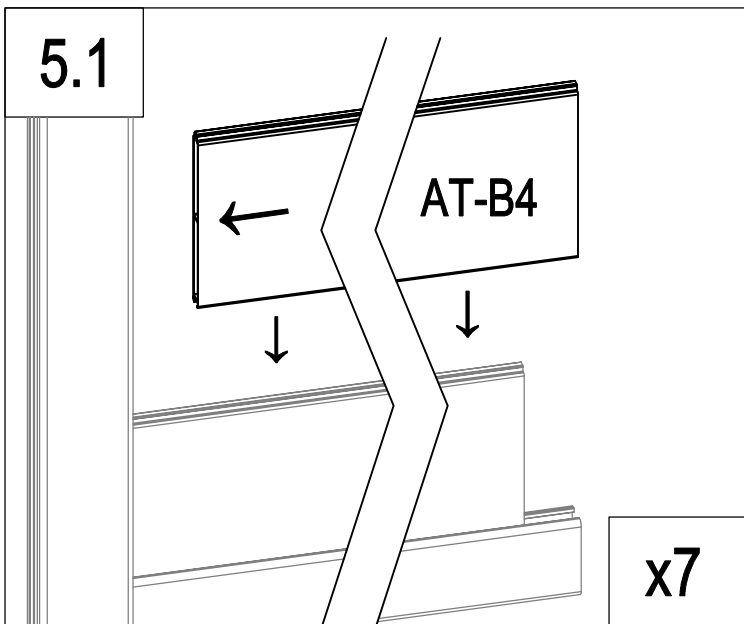
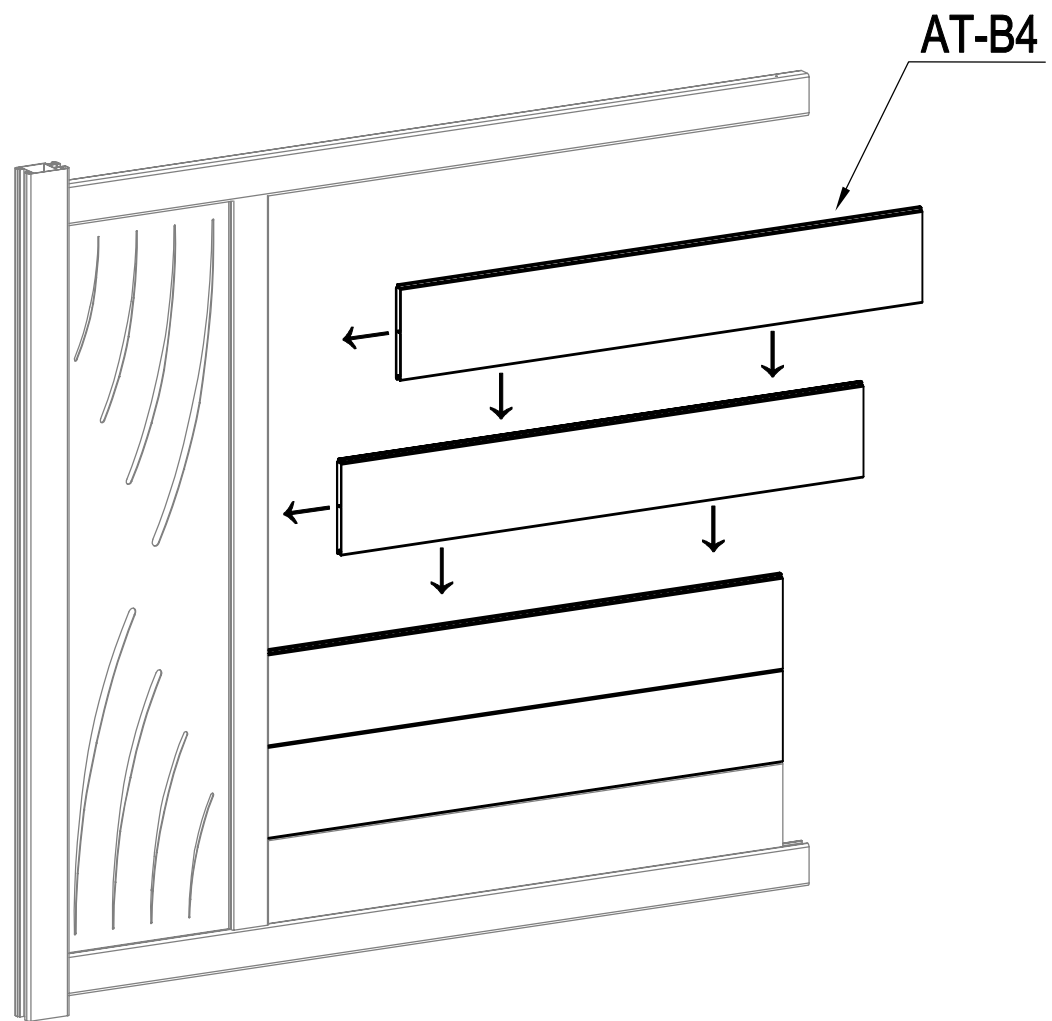

	AT-B4	7
---	-------	---

A

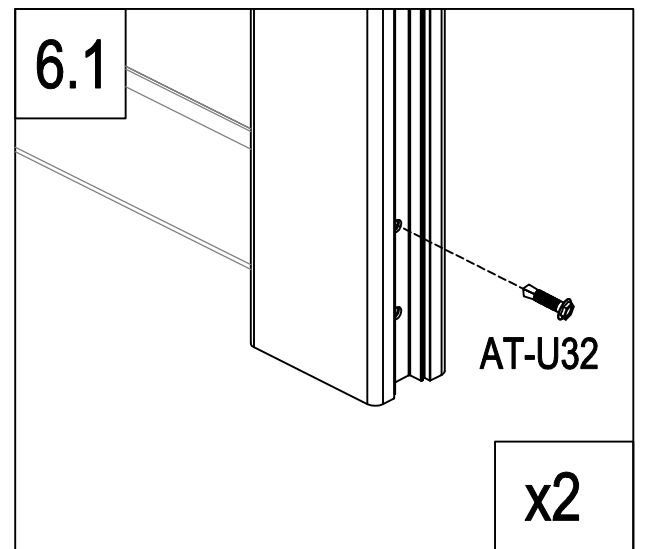
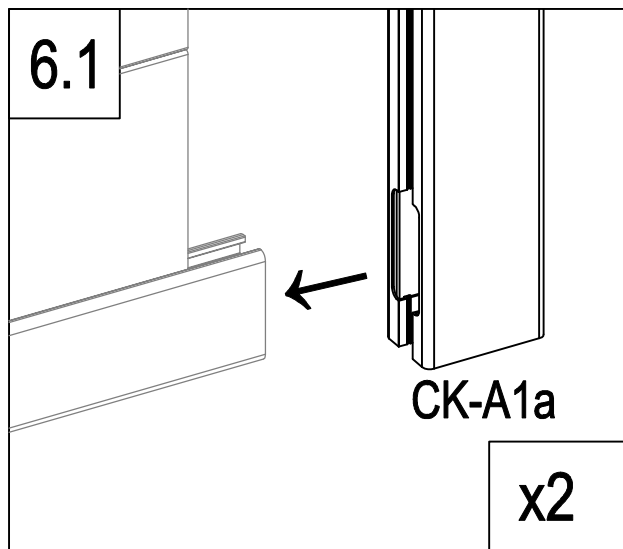
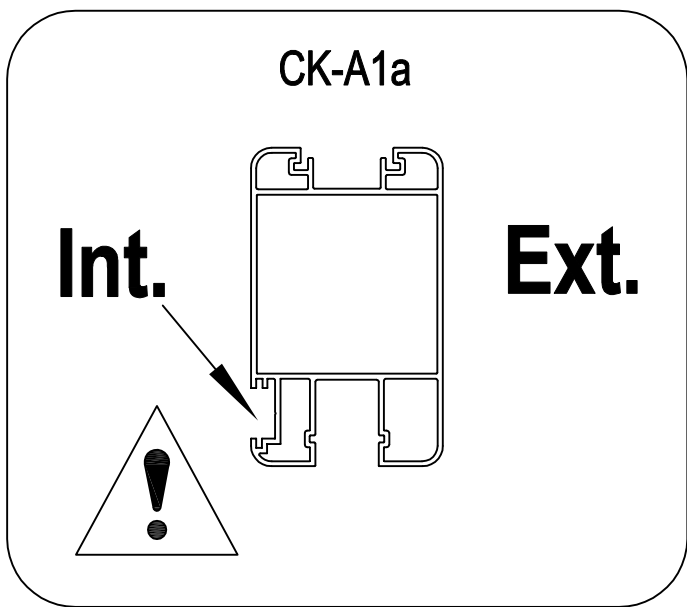
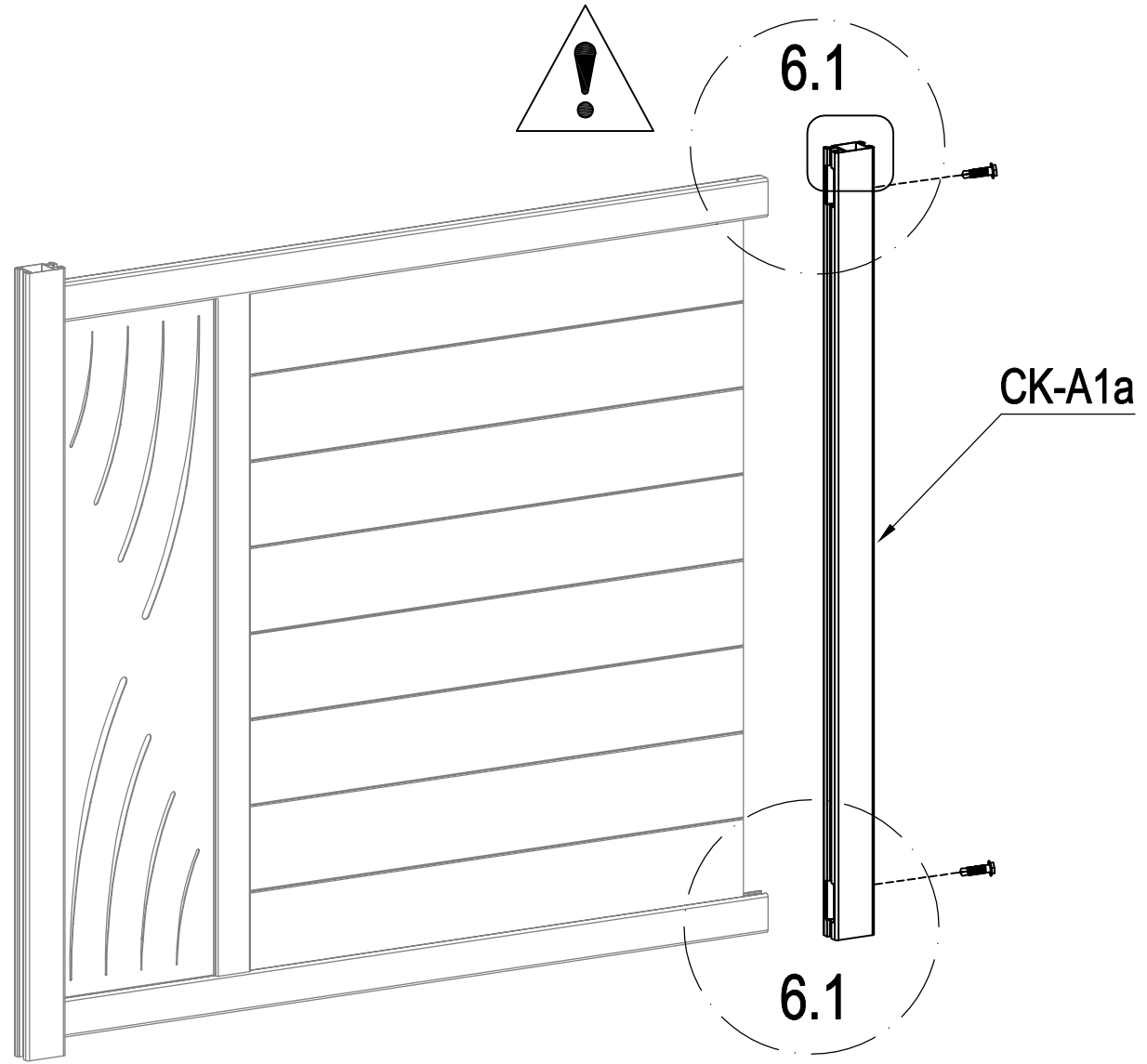

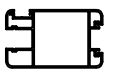
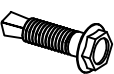
	CK-A1a	1
	AT-U32	2

A

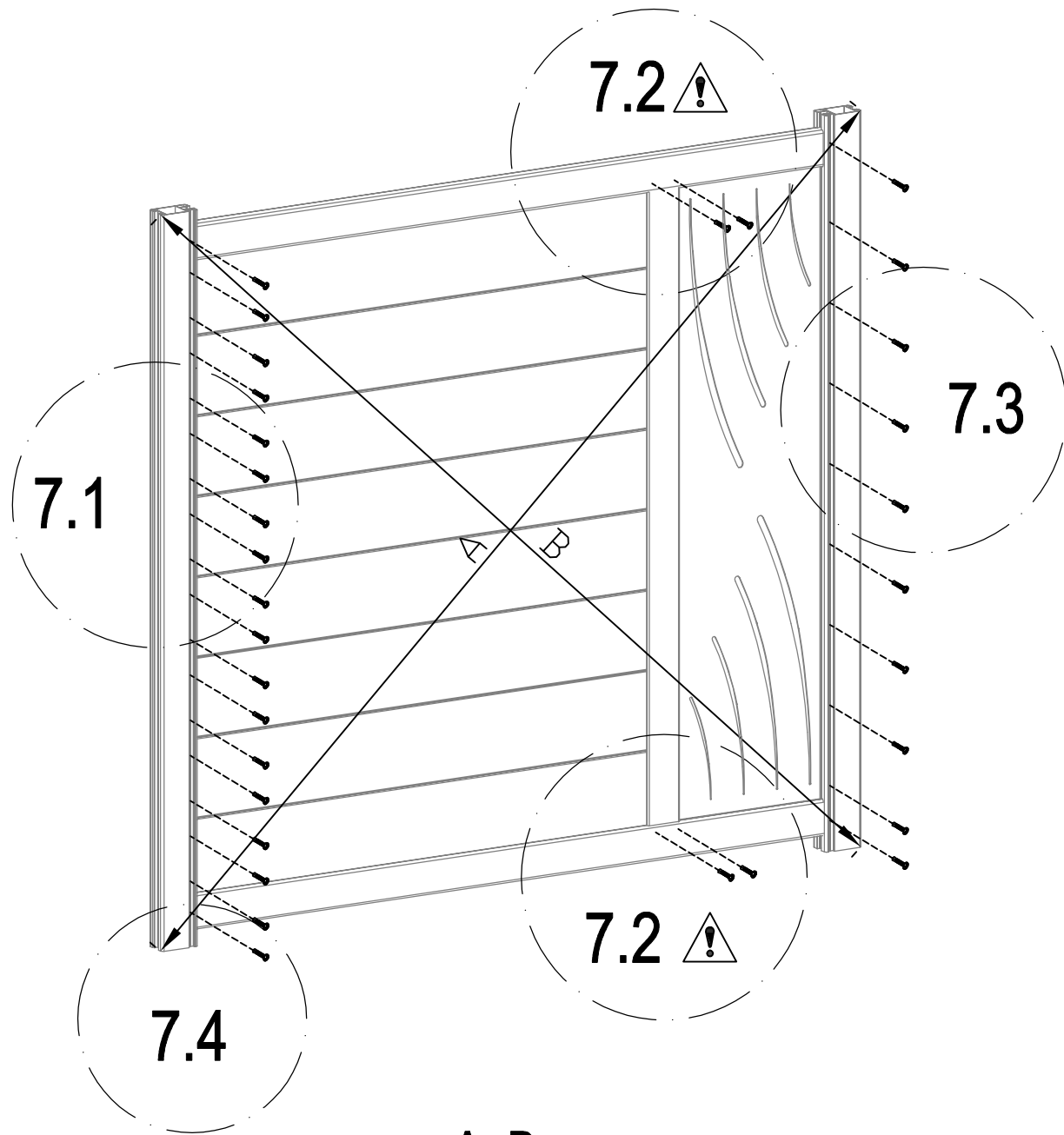
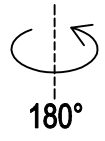

A=B

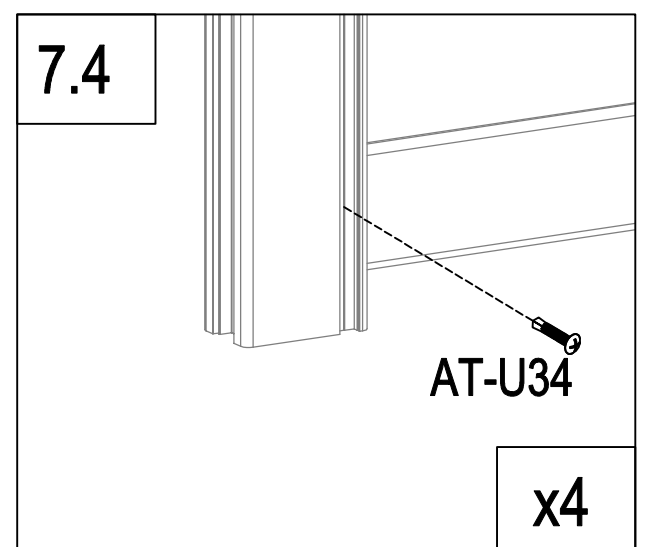
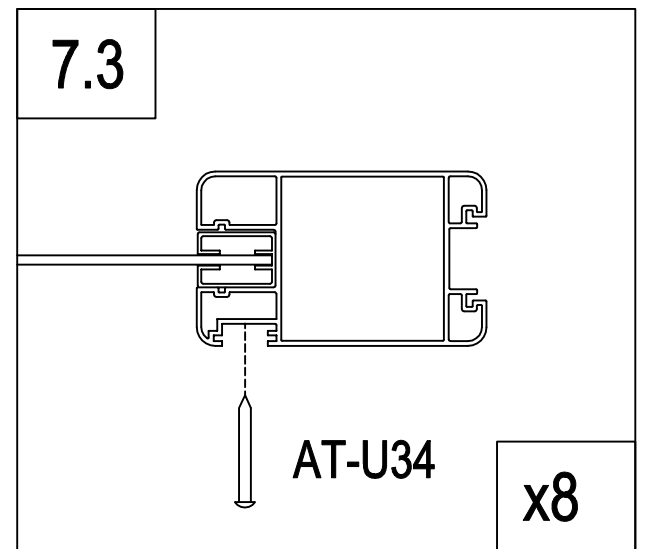
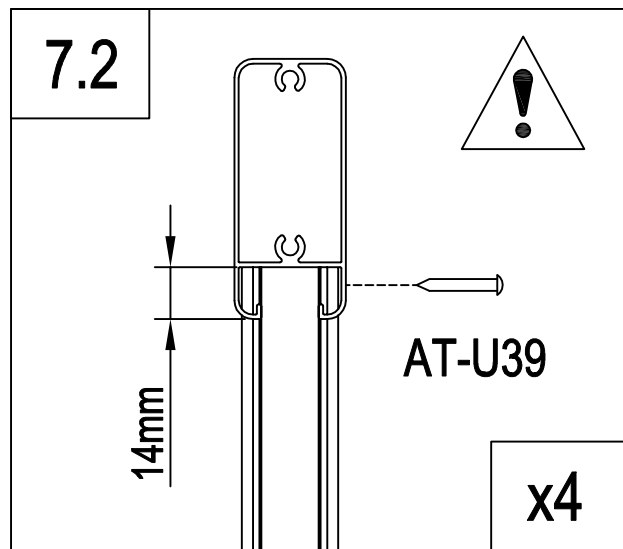
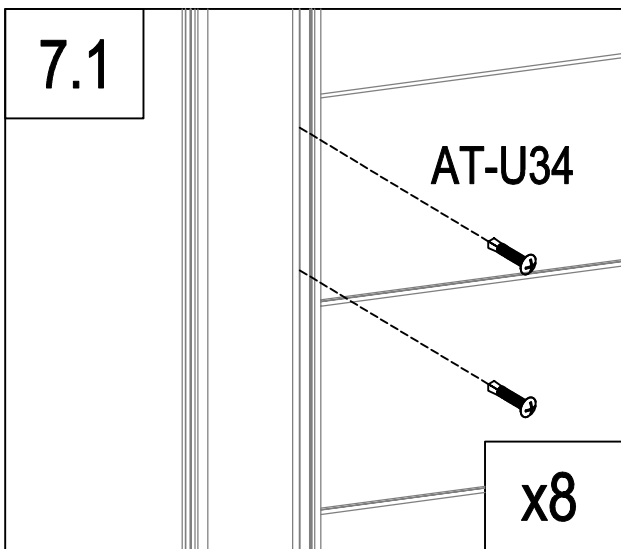

	AT-U34	28
	AT-U39	4

A

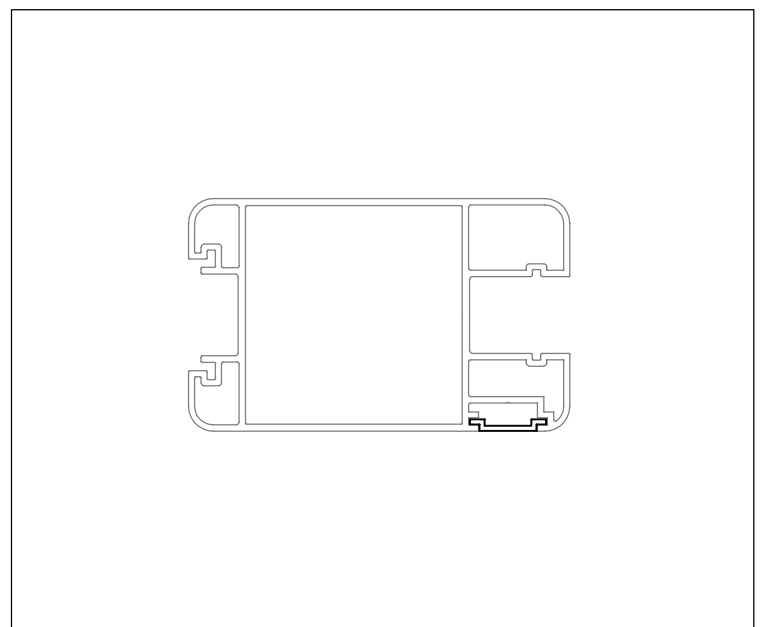
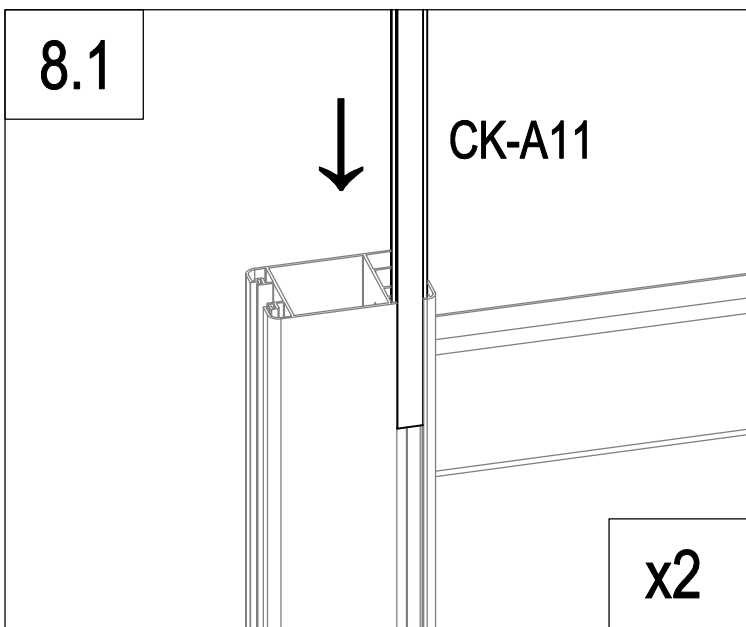
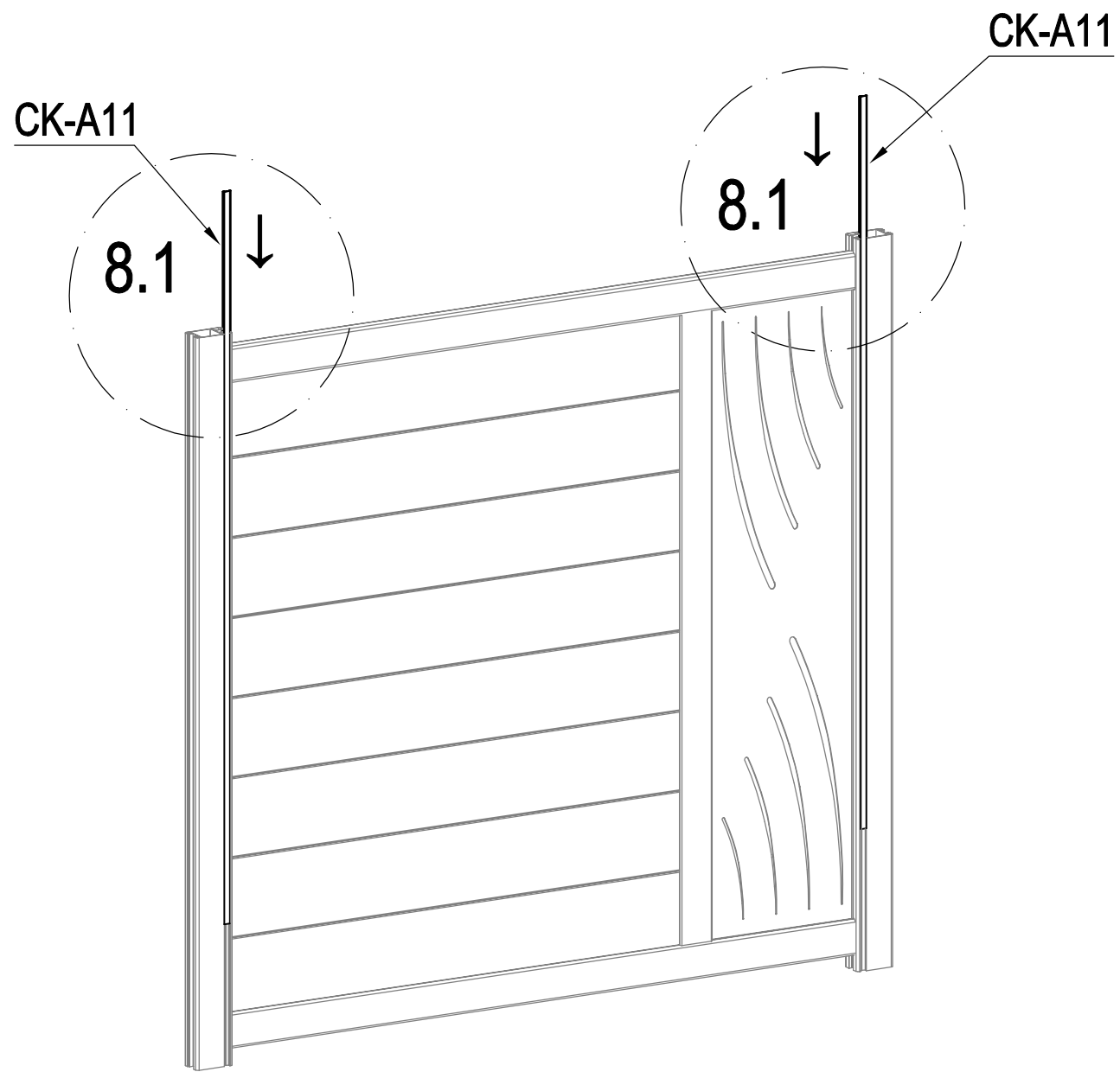



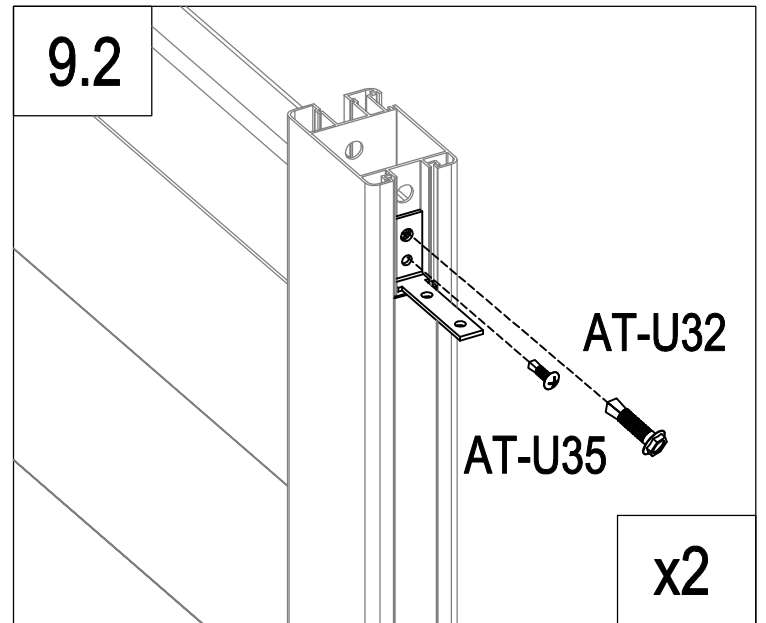
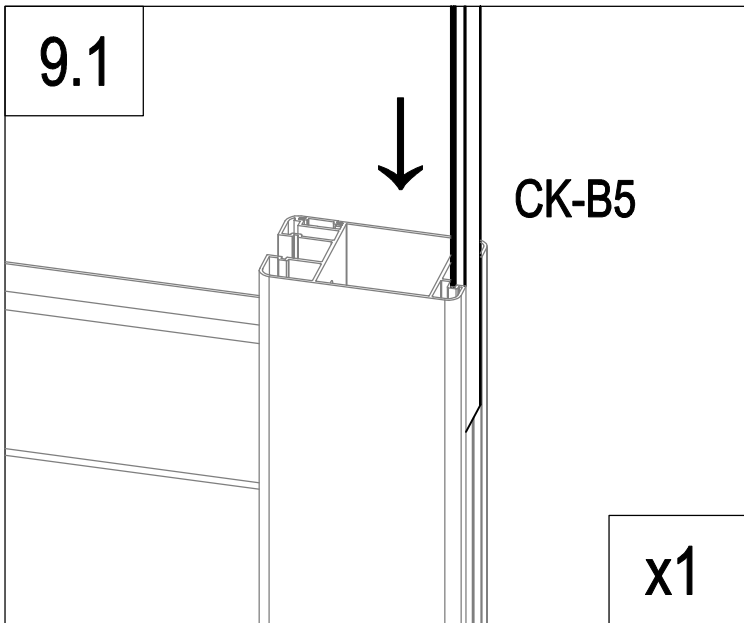
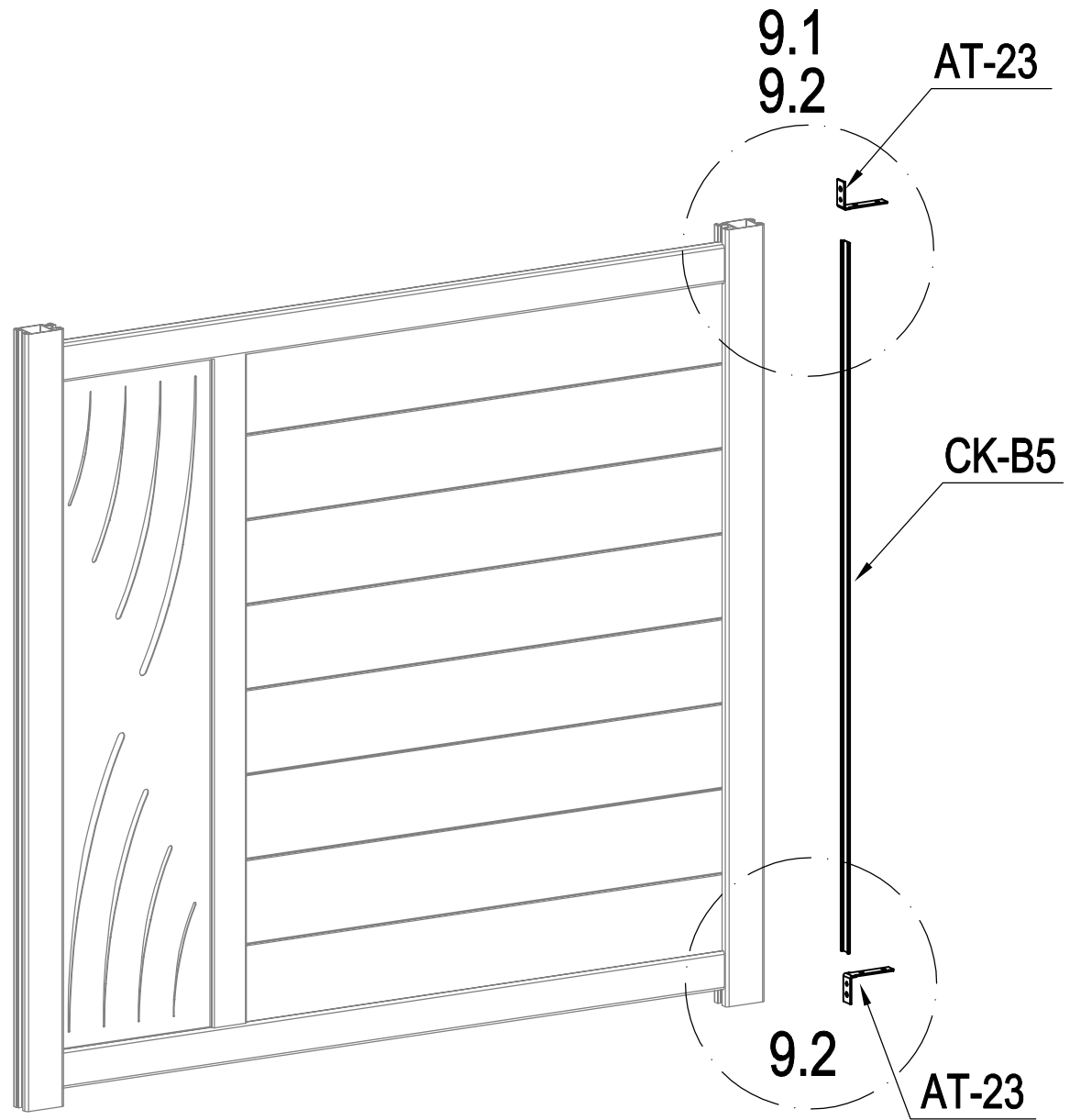

	CK-A11	2
---	--------	---

A

180°



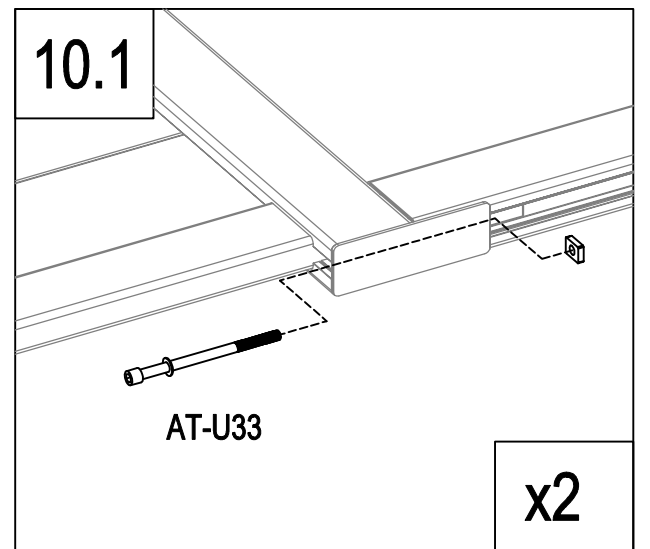
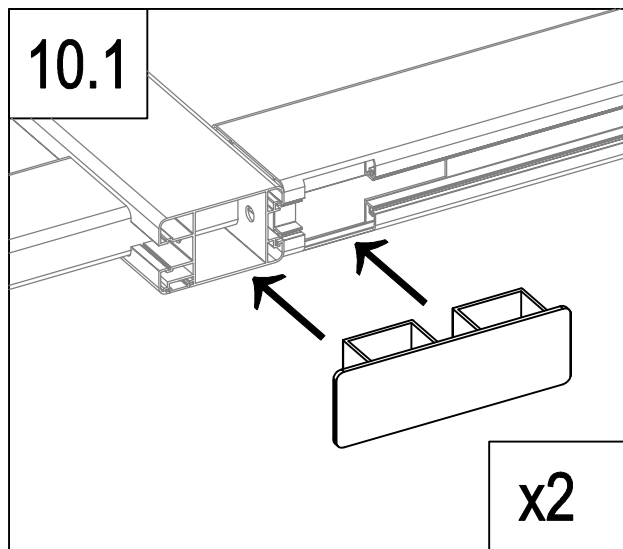
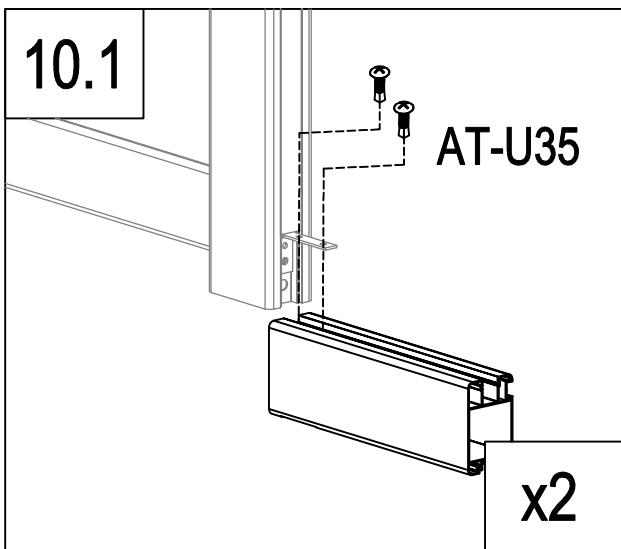
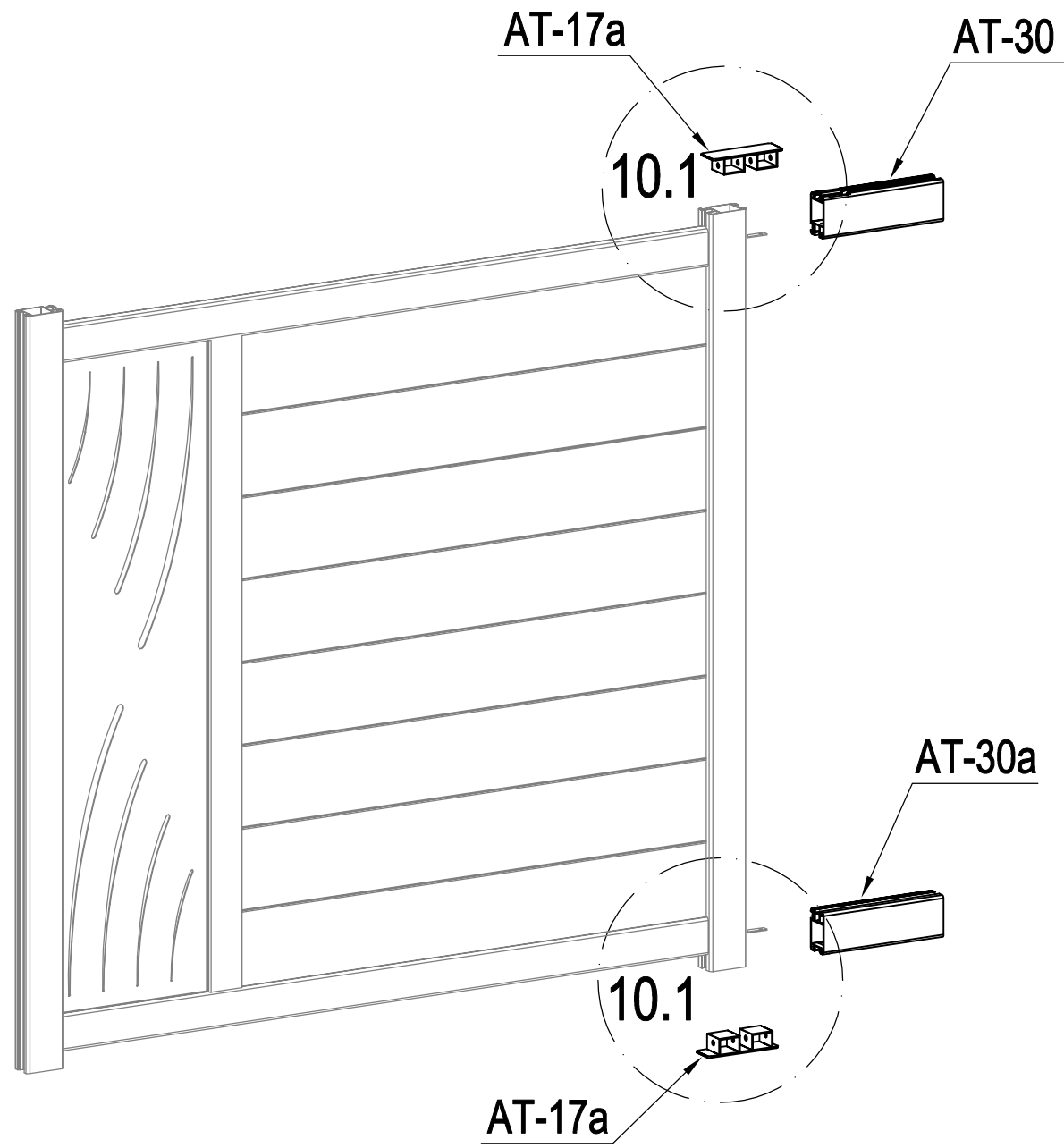

	CK-B5	1
	AT-23	2
	AT-U32	2
	AT-U35	2

A

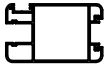
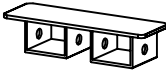



	AT-30	1
	AT-30a	1
	AT-17a	2

	AT-U33	2
	AT-U35	4

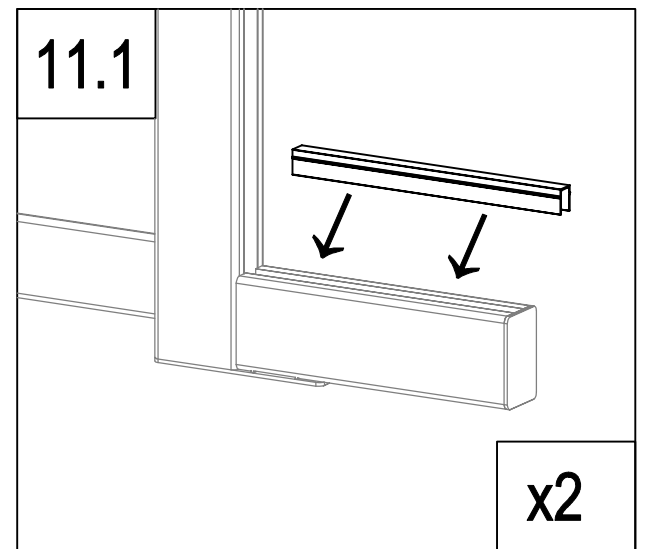
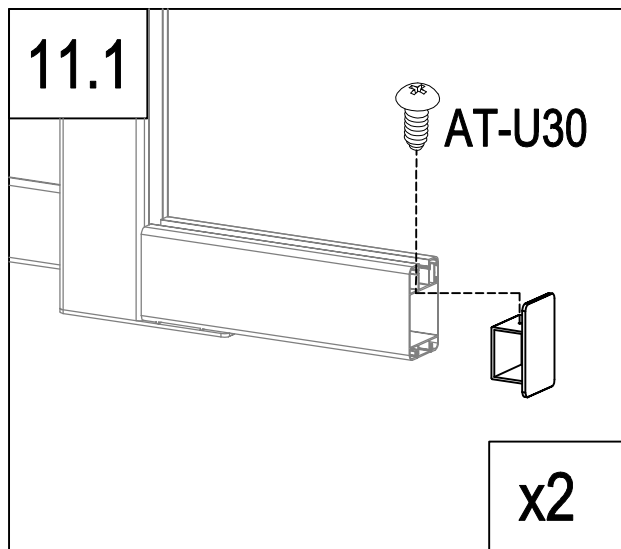
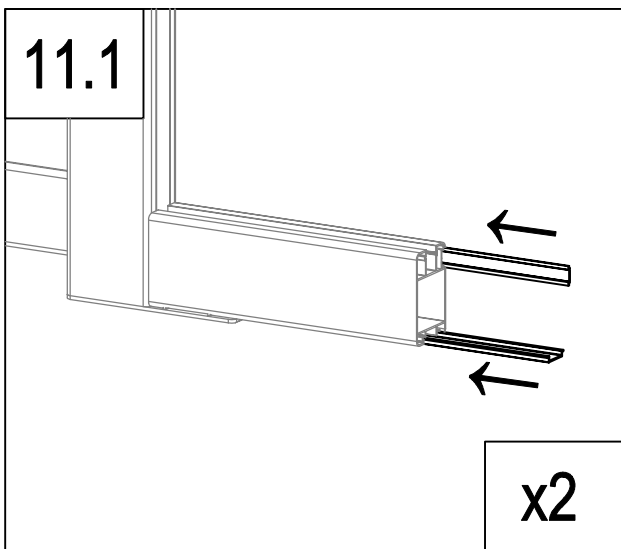
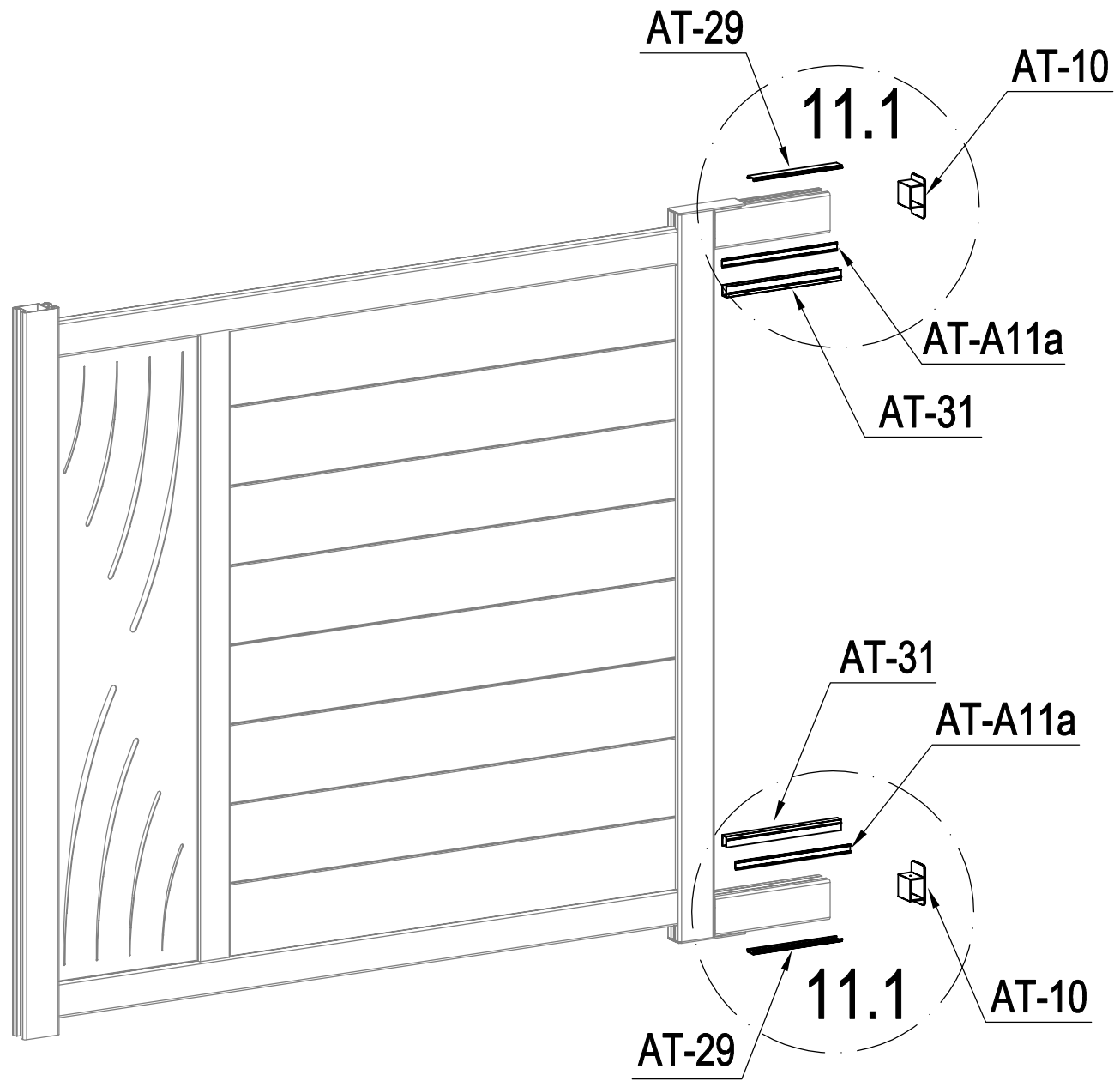
A

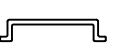
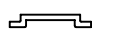
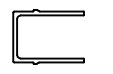

	AT-29	2
	AT-A11a	2
	AT-31	2

	AT-10	2
	AT-U30	2

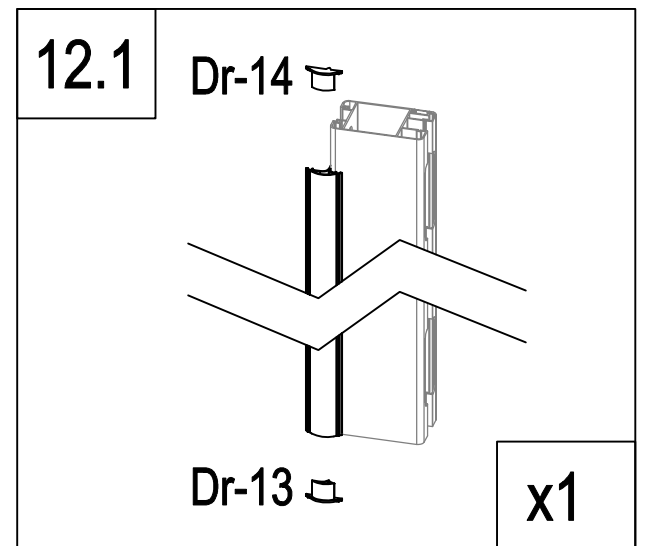
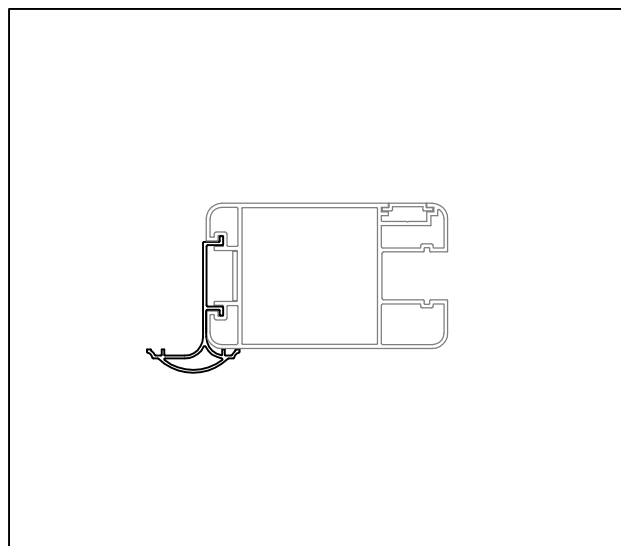
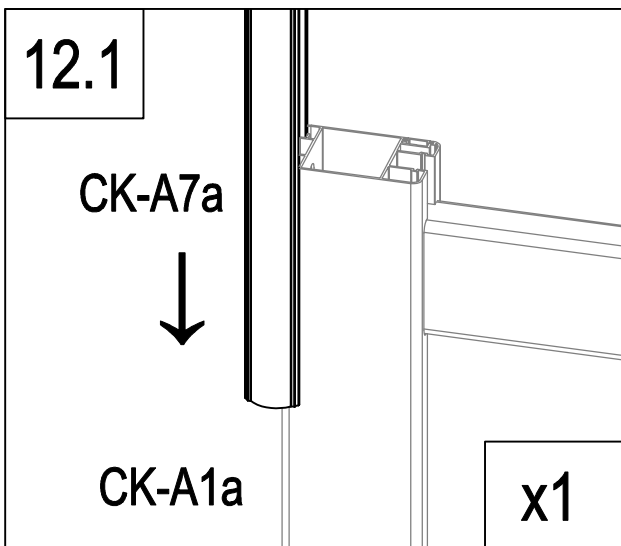
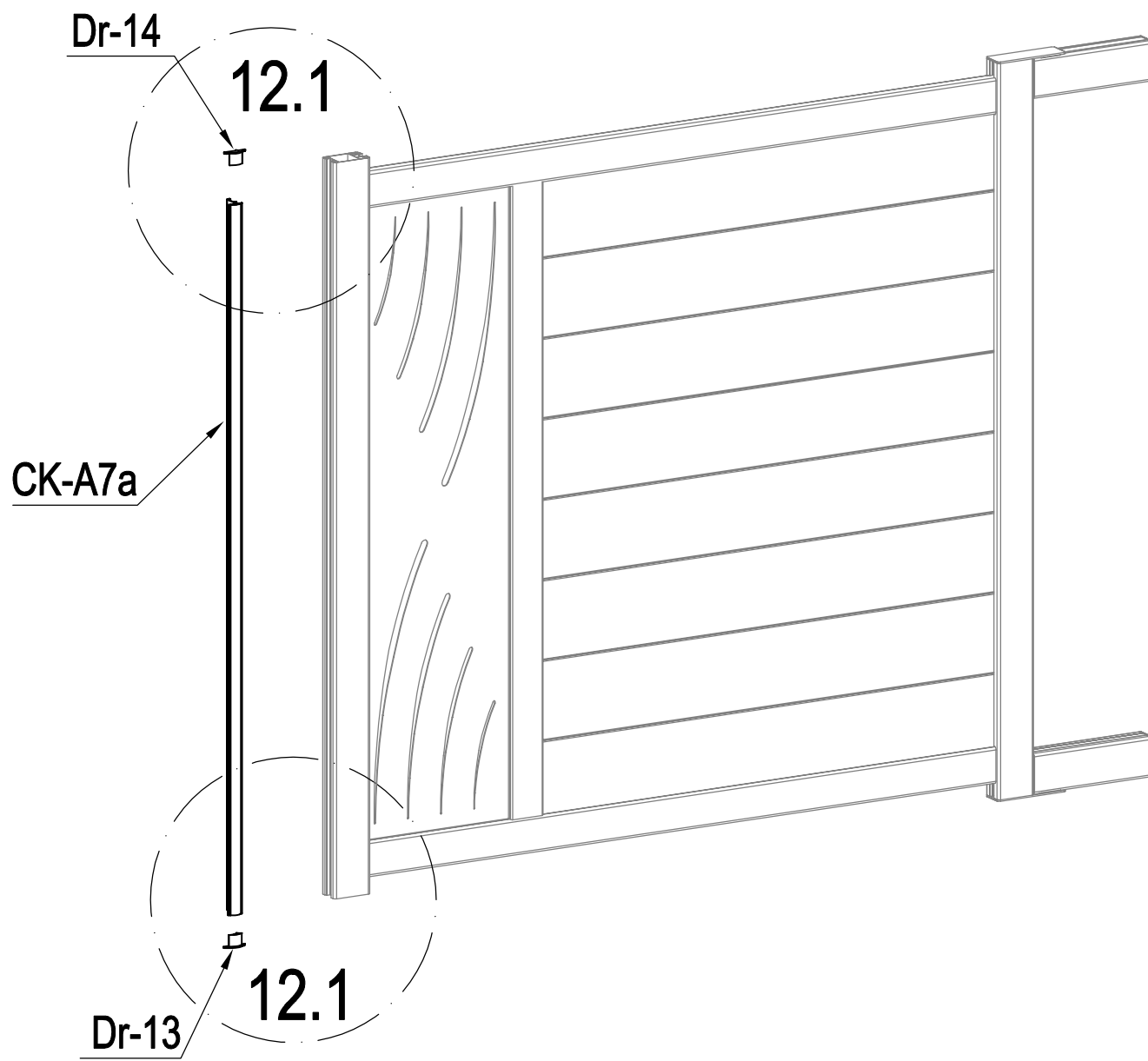

A

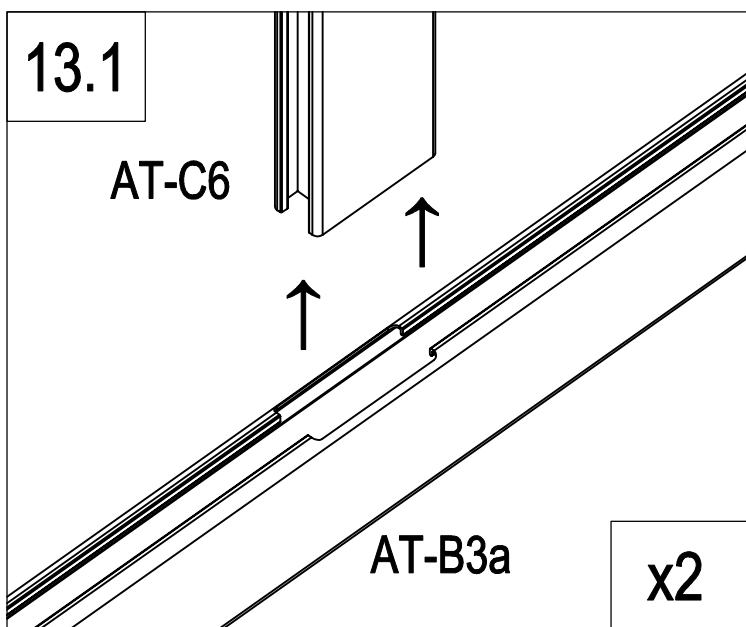
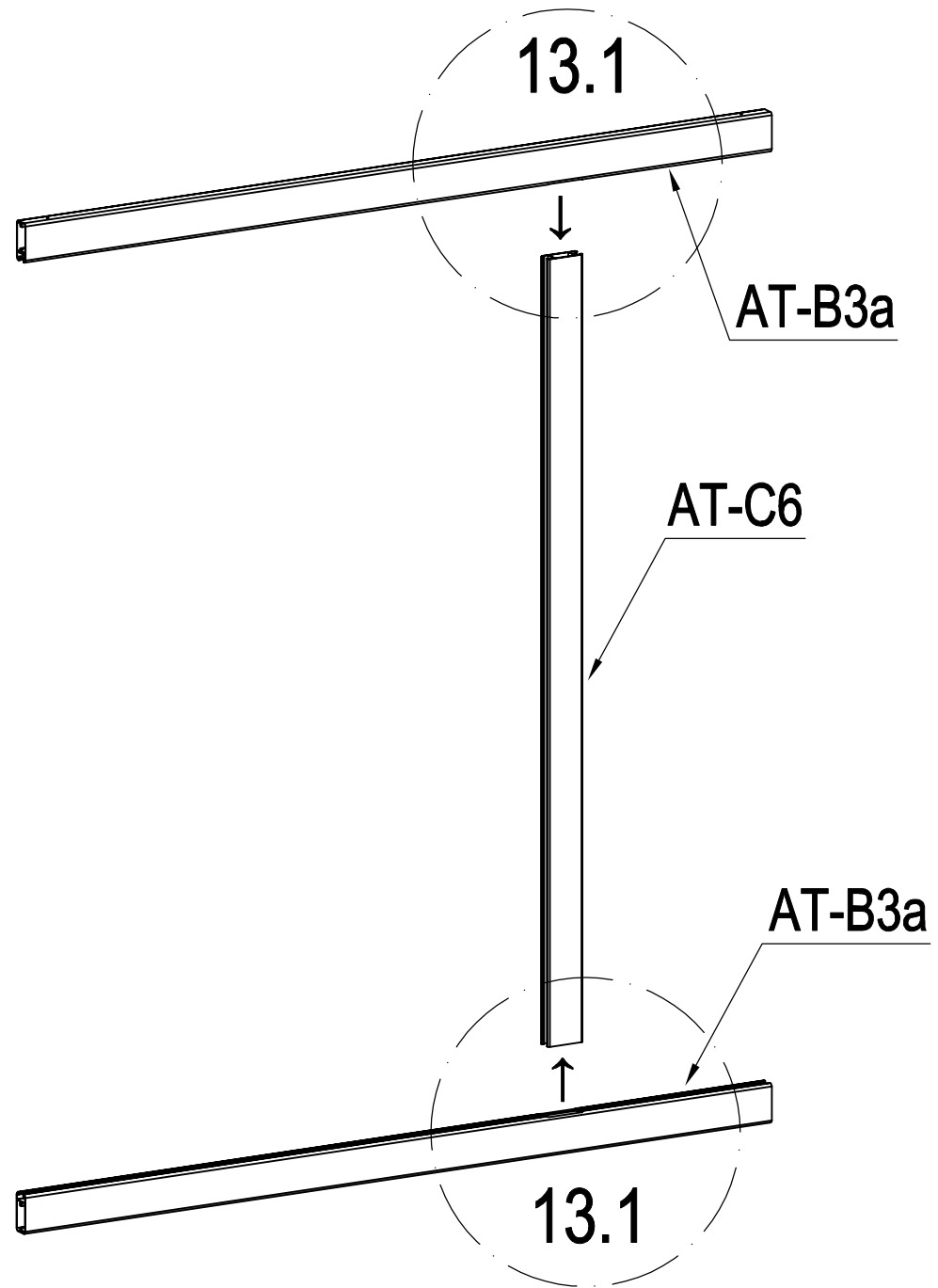

	CK-A7a	1
	Dr-13	1
	Dr-14	1

A



	AT-C6	1
	AT-B3a	2

A

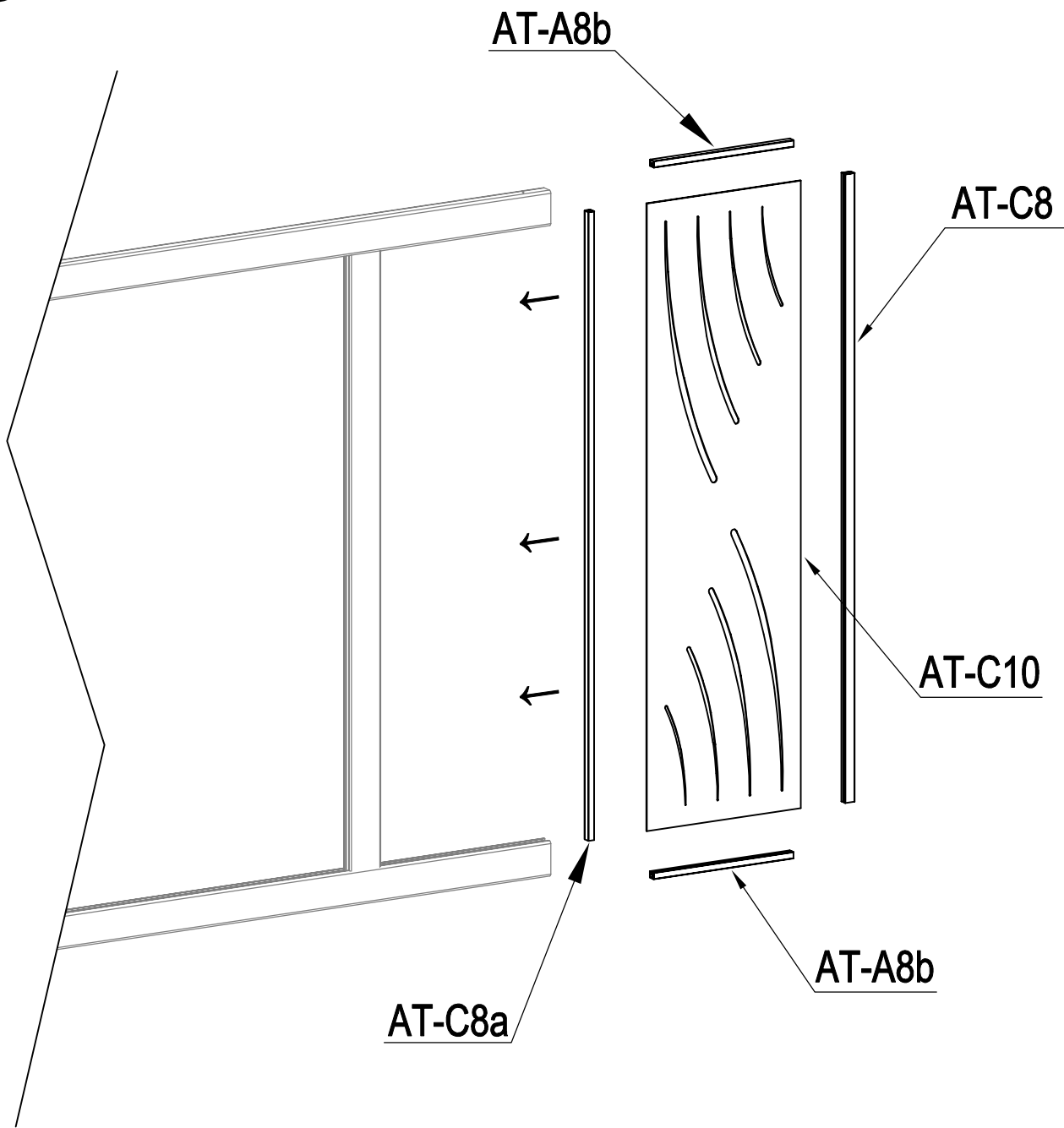

EN :you can flip and switch the direction of this plate to personalize your gate
 FR: vous pouvez retourner et changer la direction de cette plaque pour personnaliser votre portail
 DE: Sie können dieses Schild umdrehen und die Richtung wechseln, um Ihr Tor zu personalisieren.
 ES: puedes girar y cambiar la dirección de esta placa para personalizar tu puerta
 PT: pode virar e mudar a direção desta placa para personalizar o seu portão
 IT: potete capovolgere e cambiare la direzione di questa piastra per personalizzare il vostro cancello
 NL: u kunt de richting van deze plaat omdraaien en veranderen om uw poort te verpersoonlijken...
 PL: można obrócić i przełączyć kierunek tej płyty, aby spersonalizować bramę.

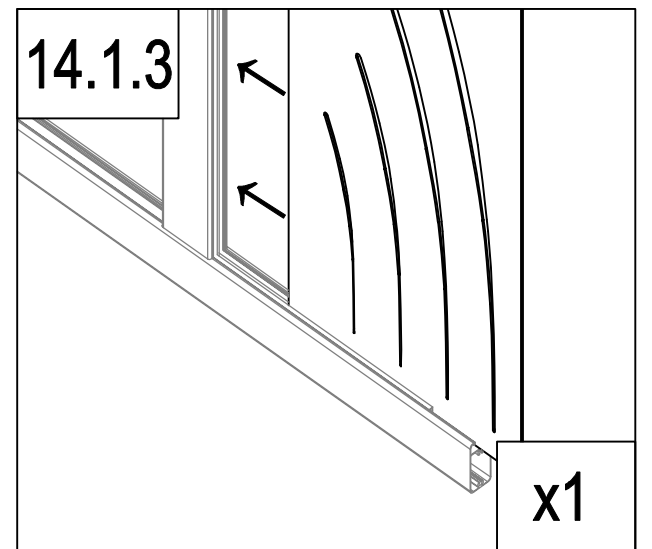
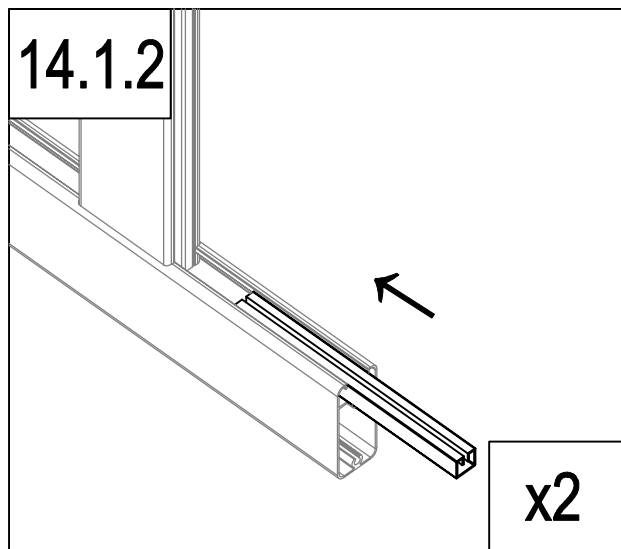
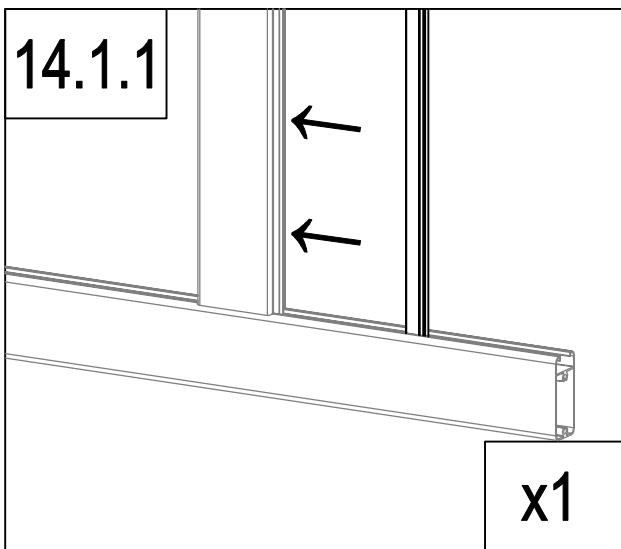

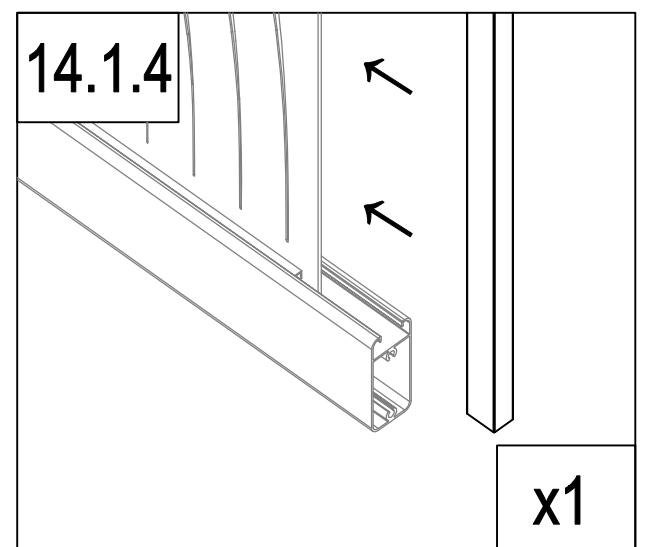

	AT-C8a	1
	AT-A8b	2
	AT-C10	1
	AT-C8	1

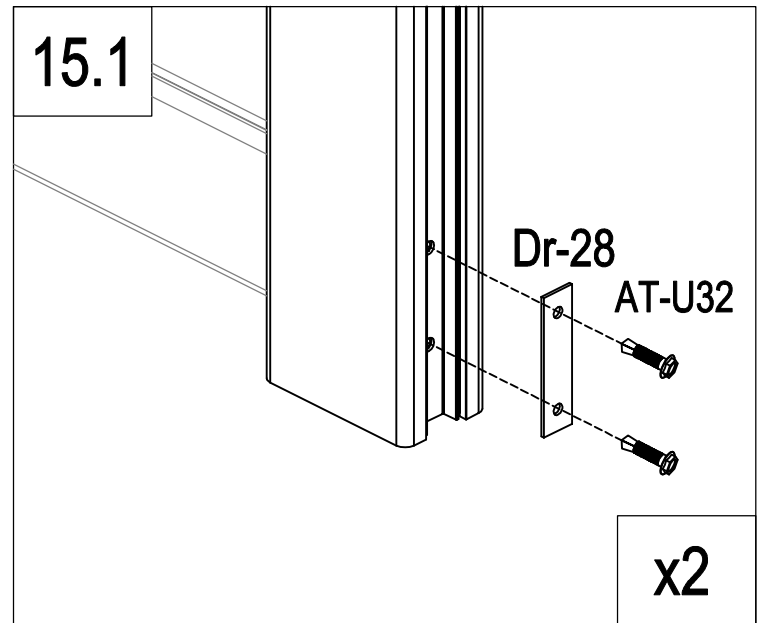
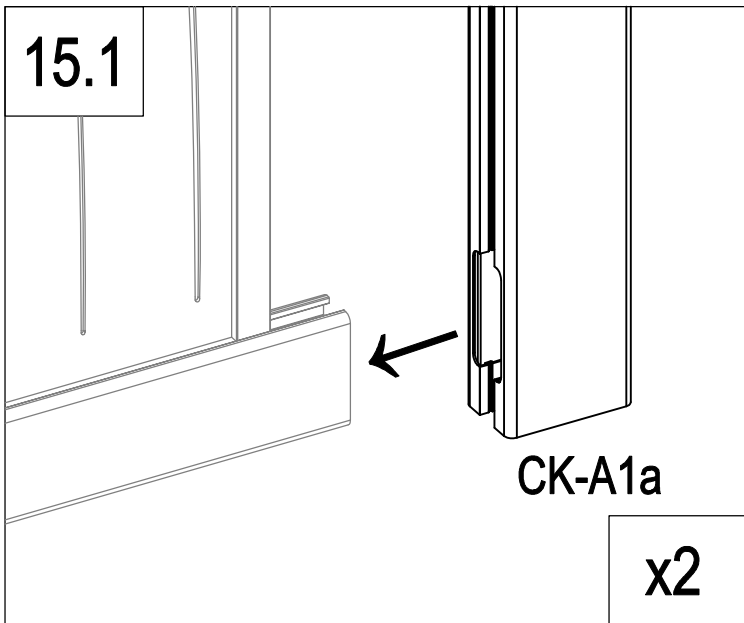
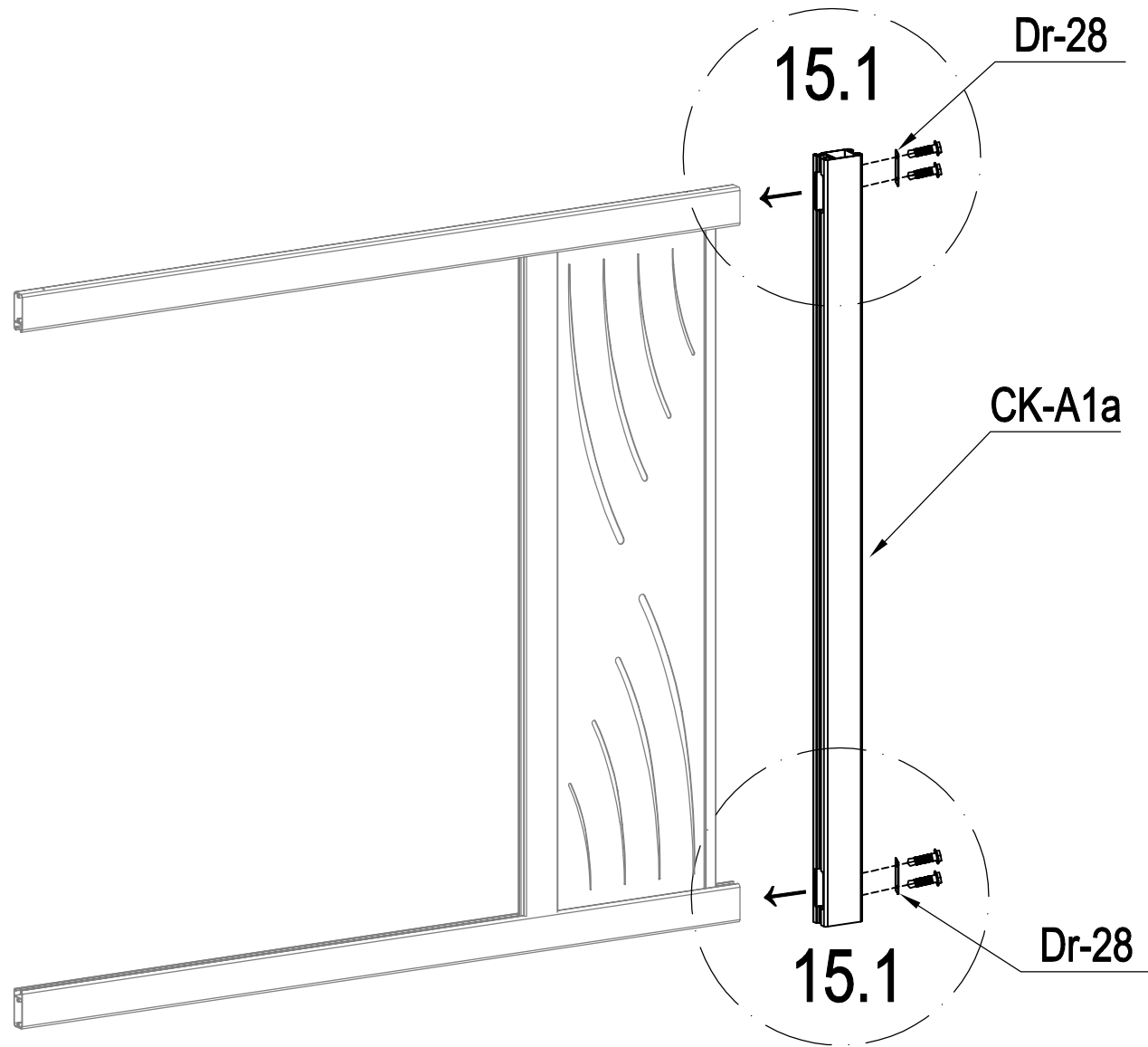

A

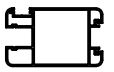

	CK-A1a	1
	Dr-28	2
	AT-U32	4

A

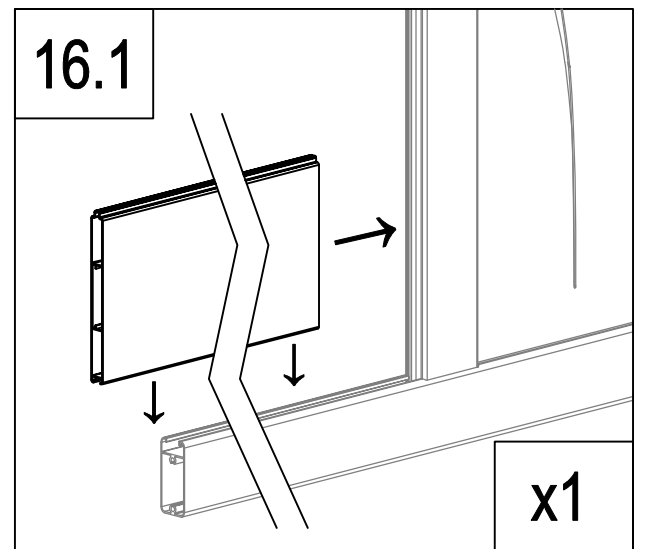
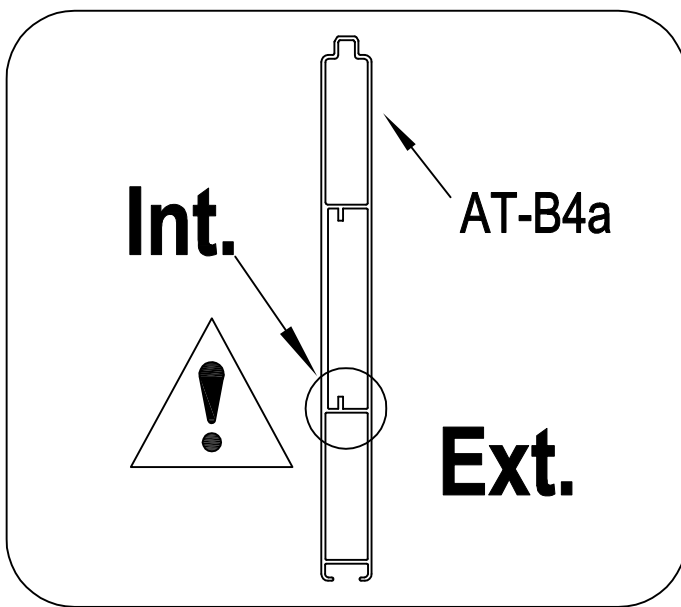
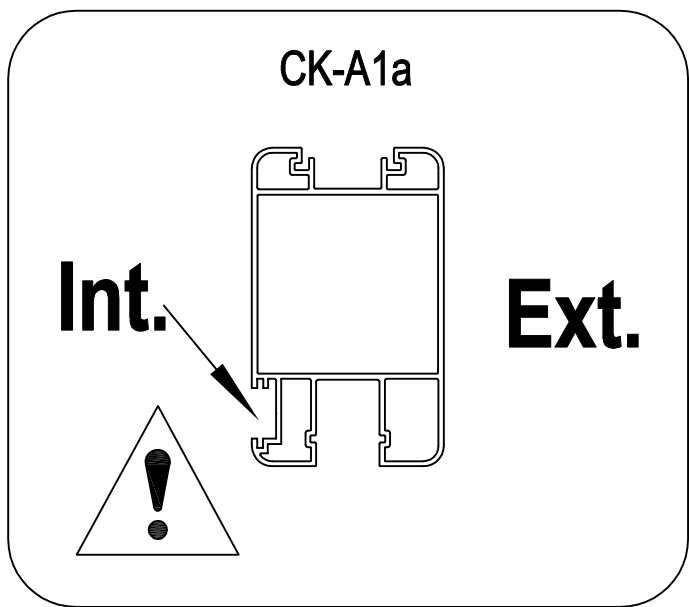
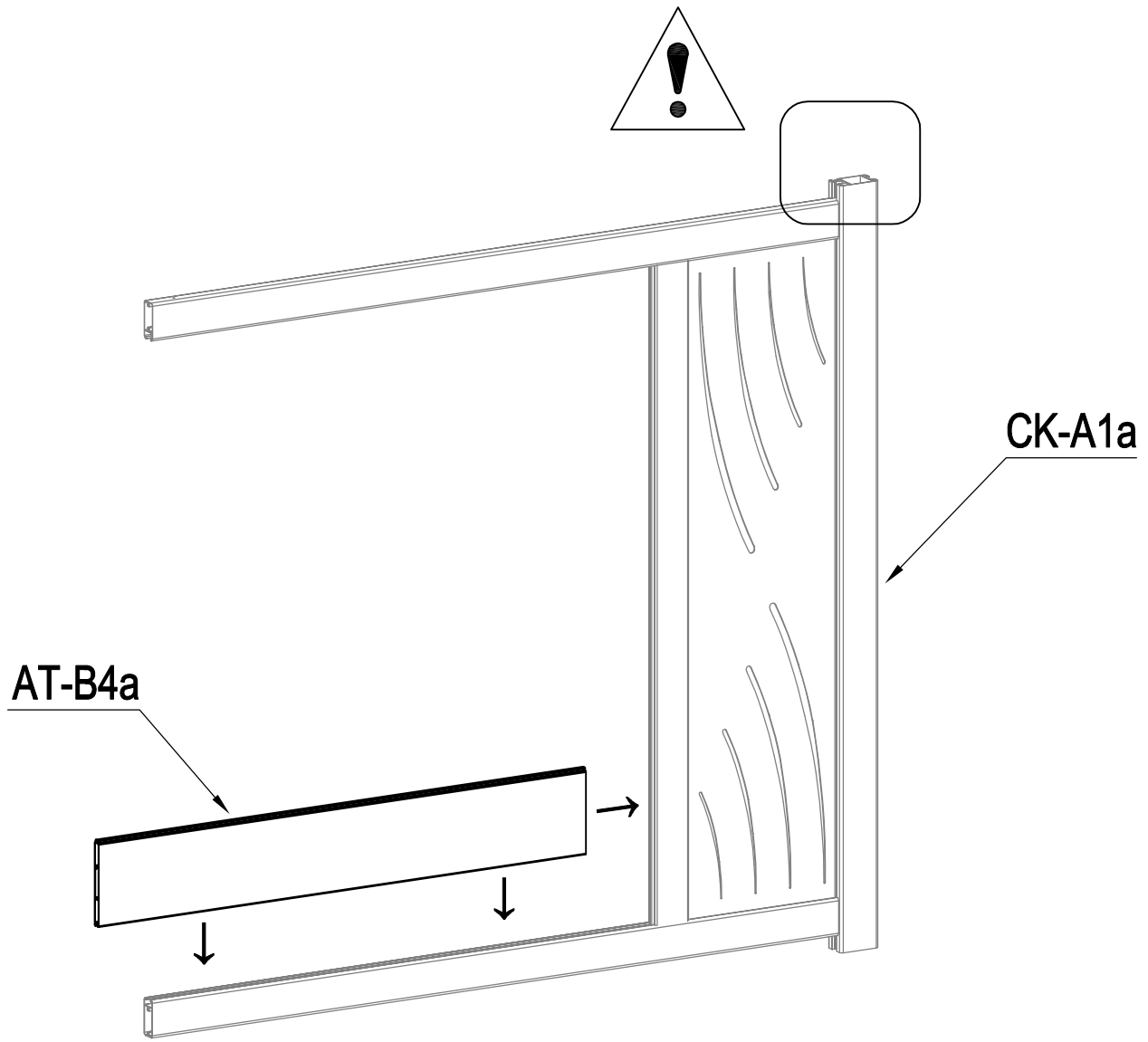

	AT-B4a	1
---	--------	---

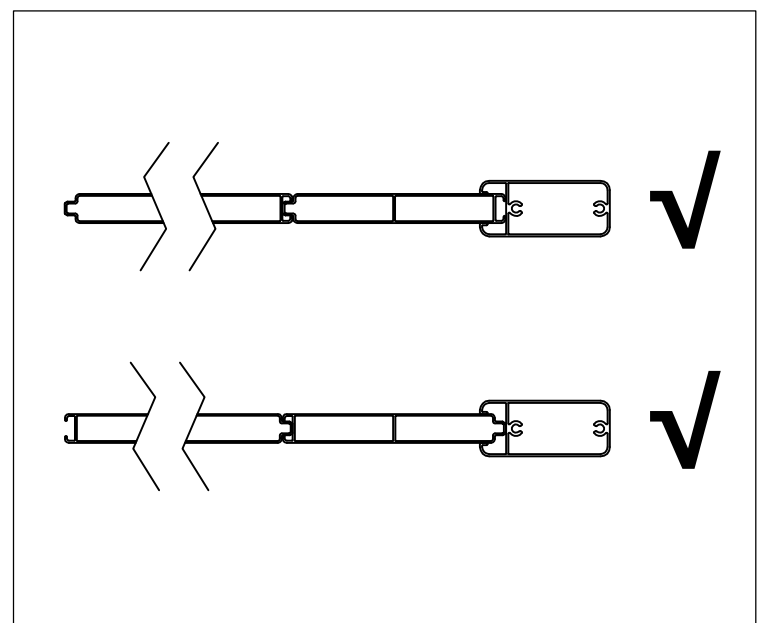
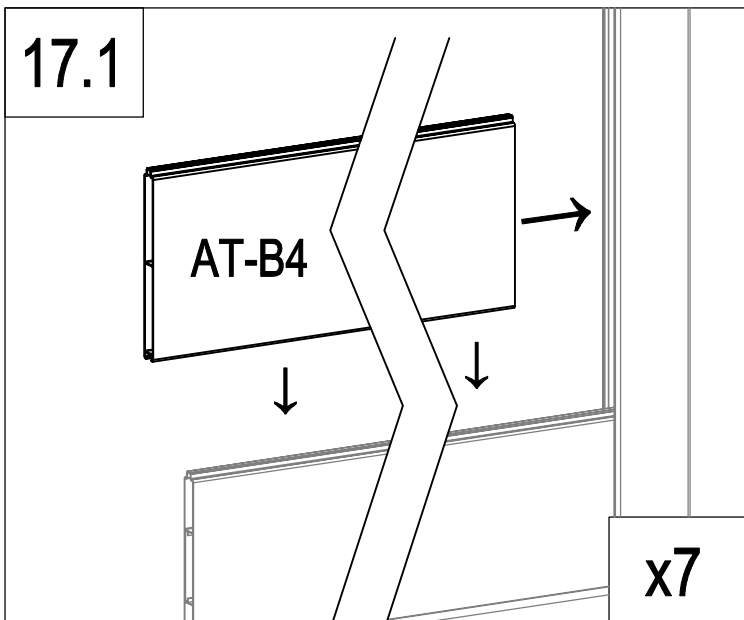
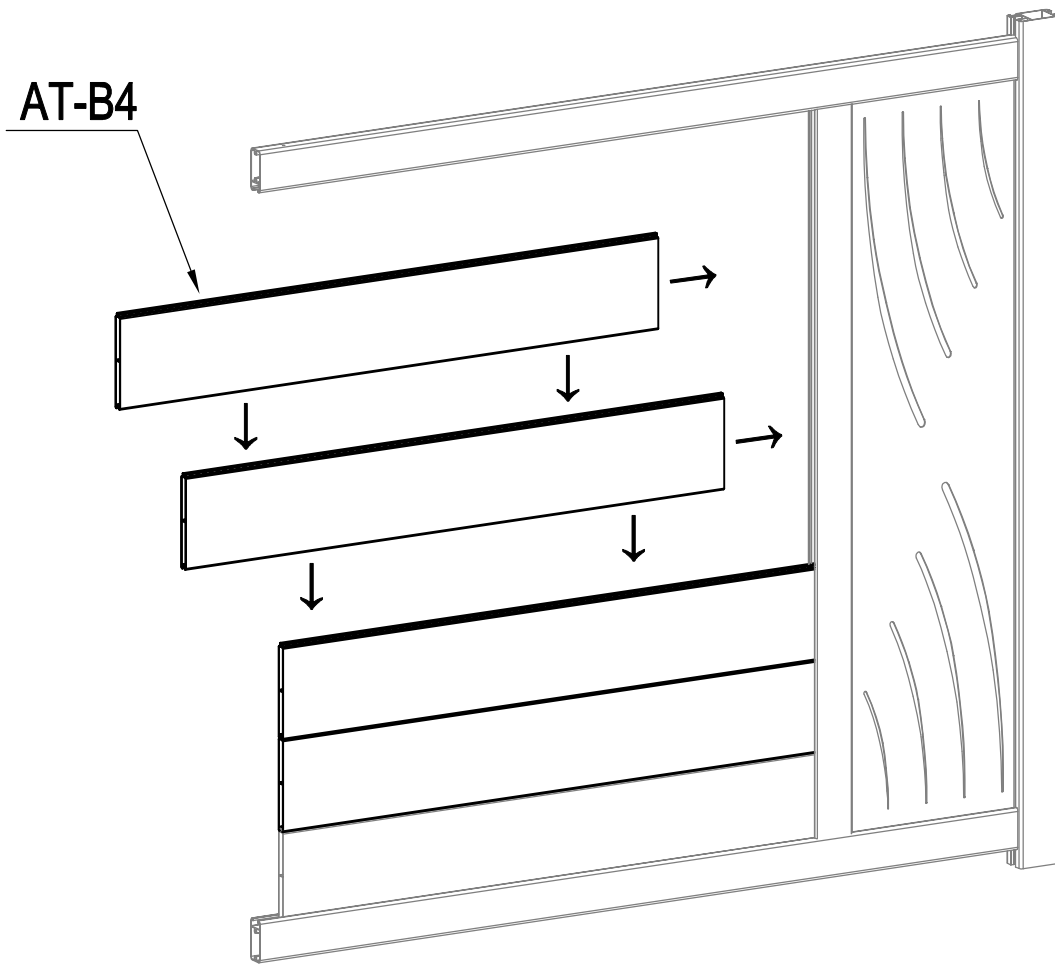

A

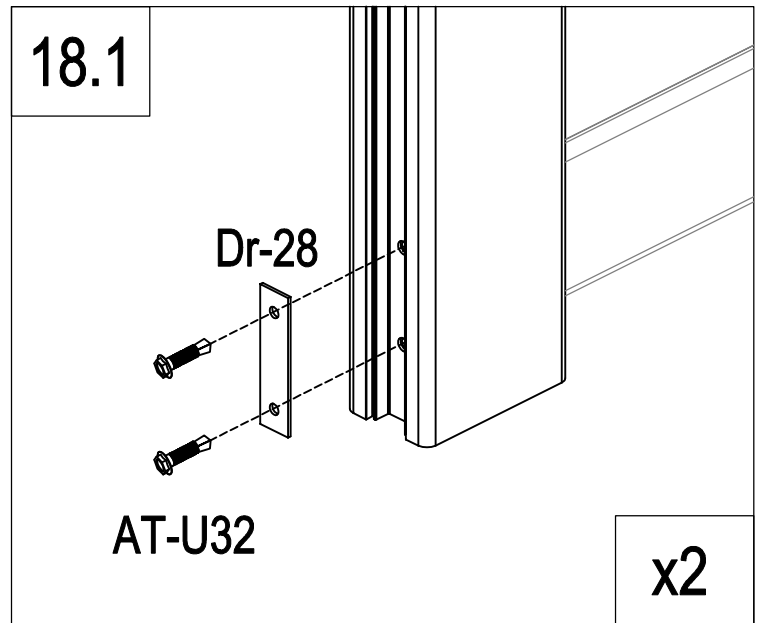
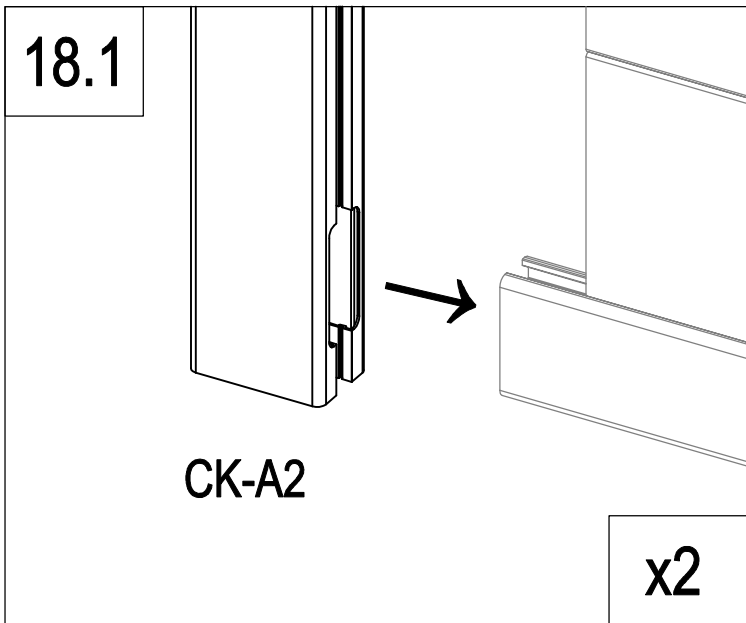
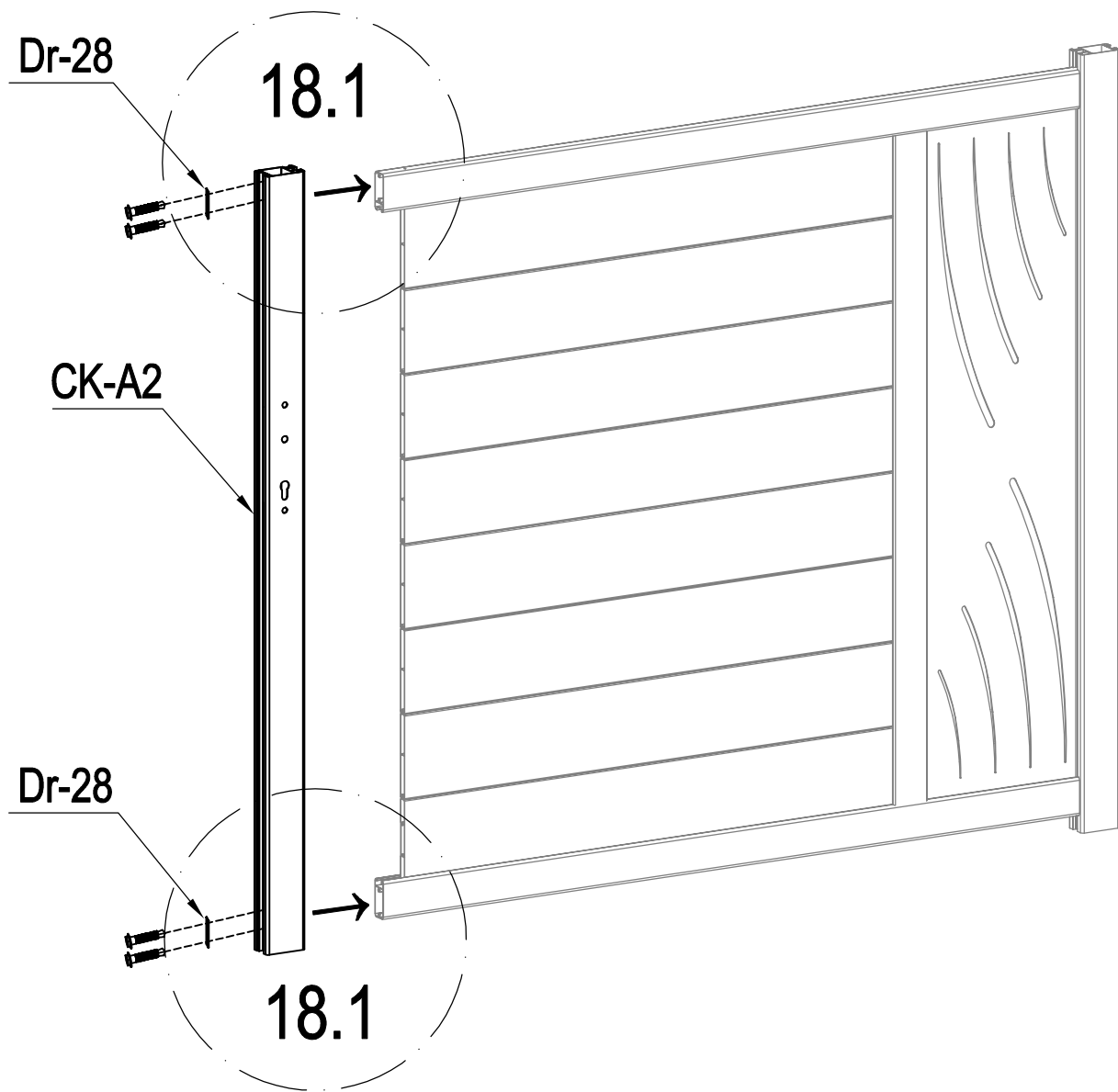

	AT-B4	7
---	-------	---

A

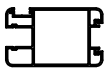



	CK-A2	1
	Dr-28	2
	AT-U32	4

A

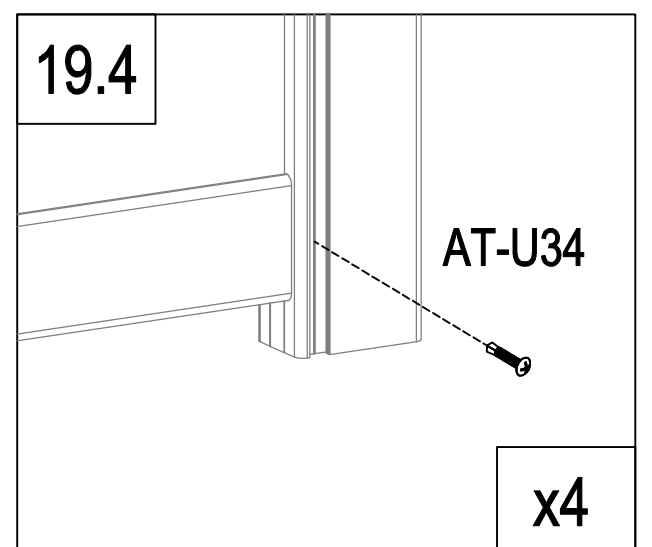
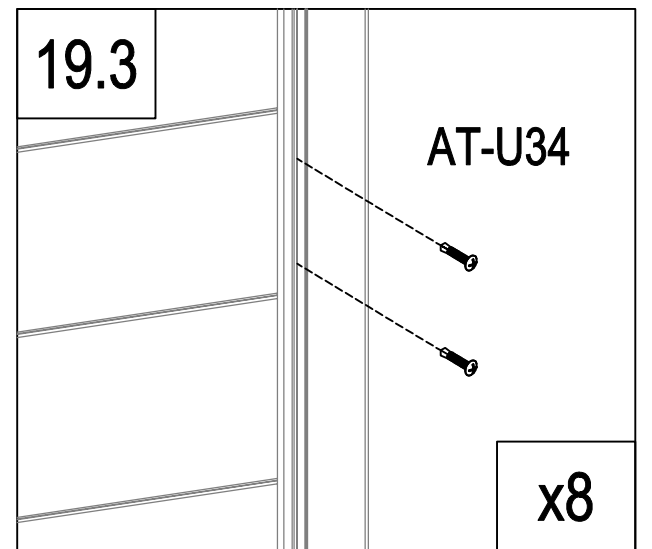
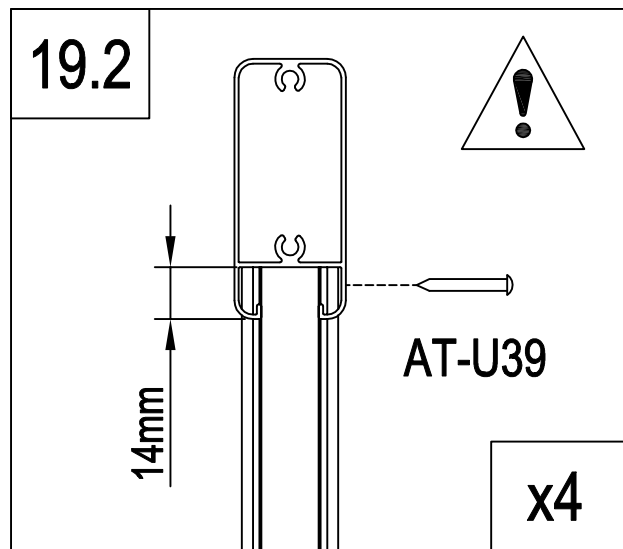
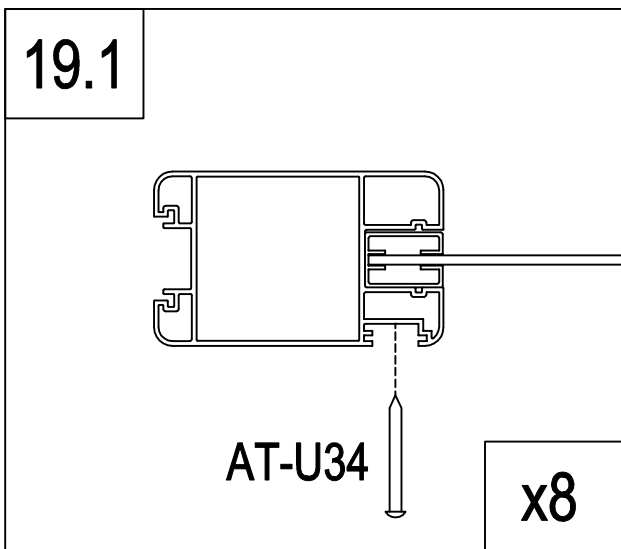
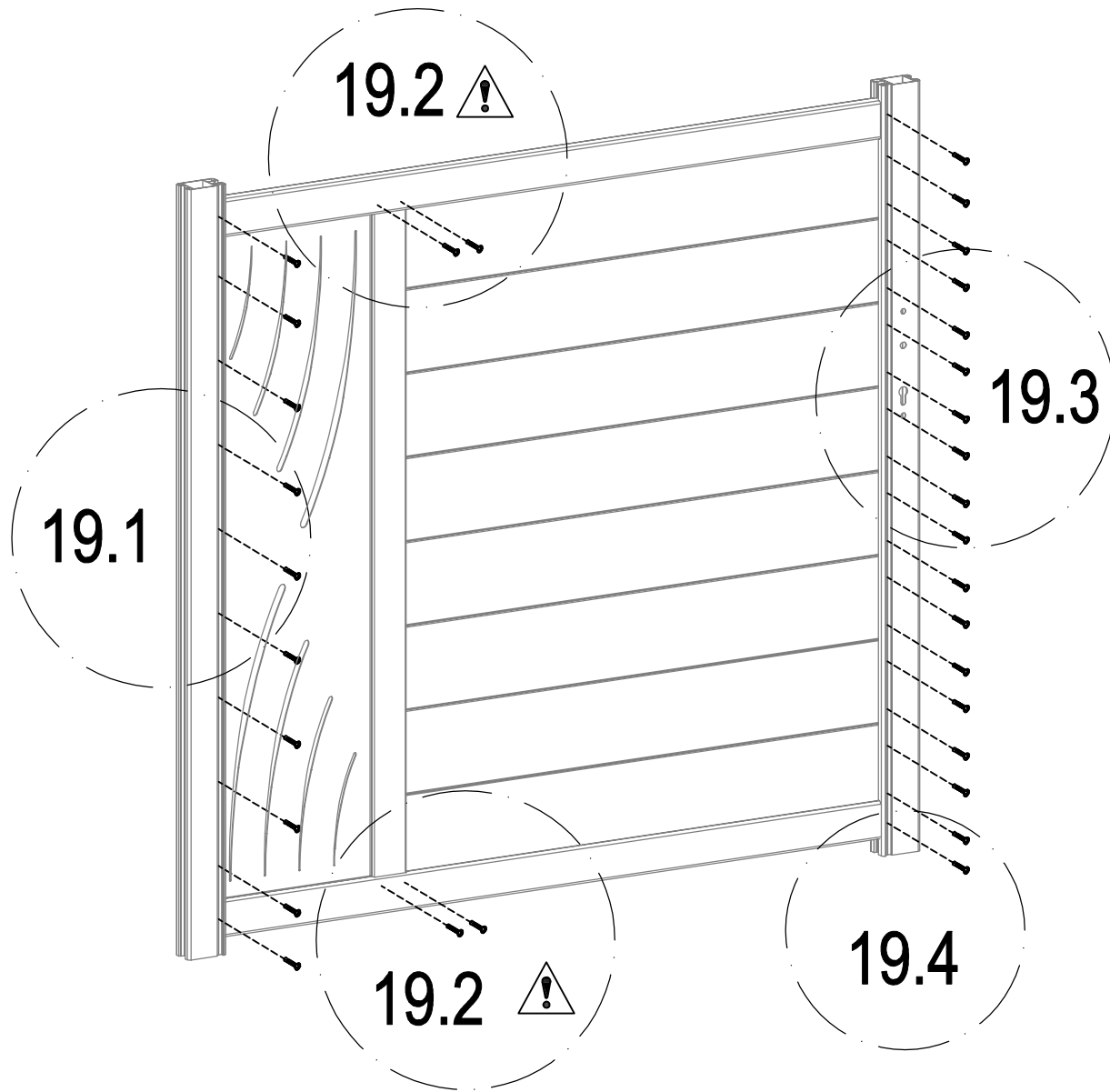
180°



	AT-U34	28
	AT-U39	4

A

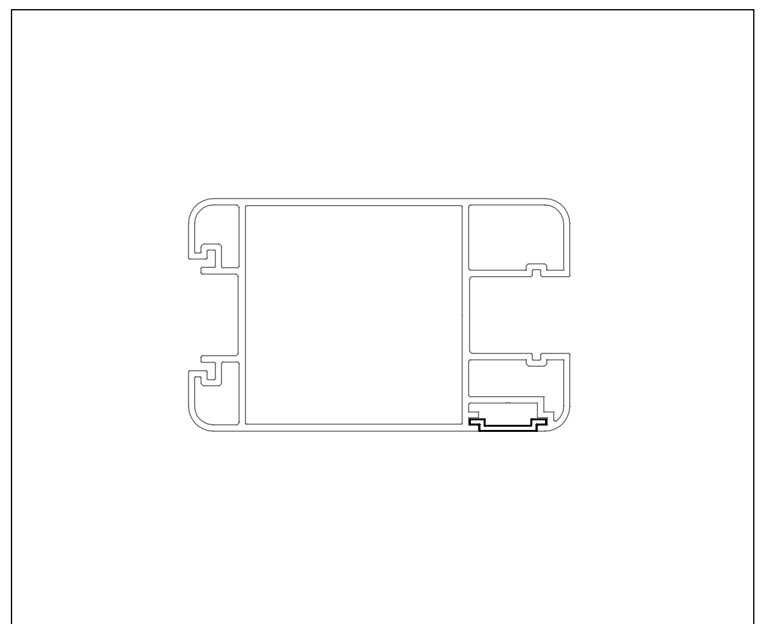
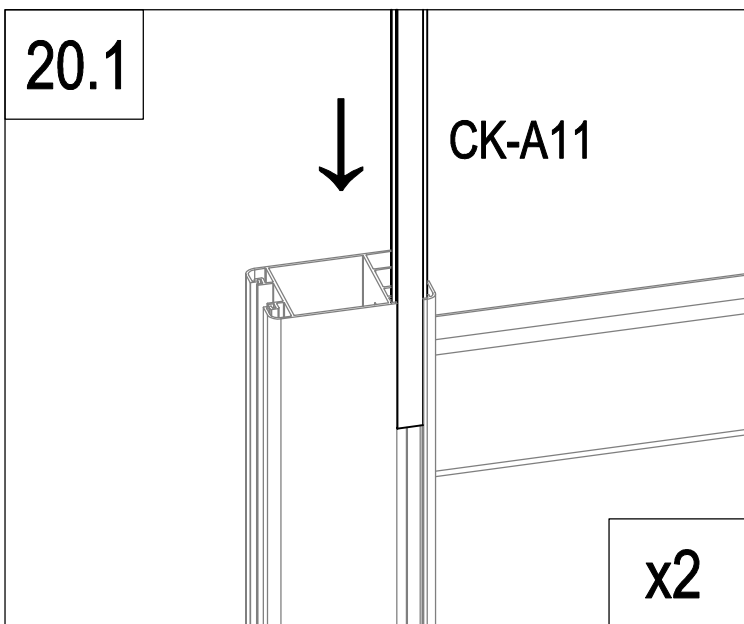
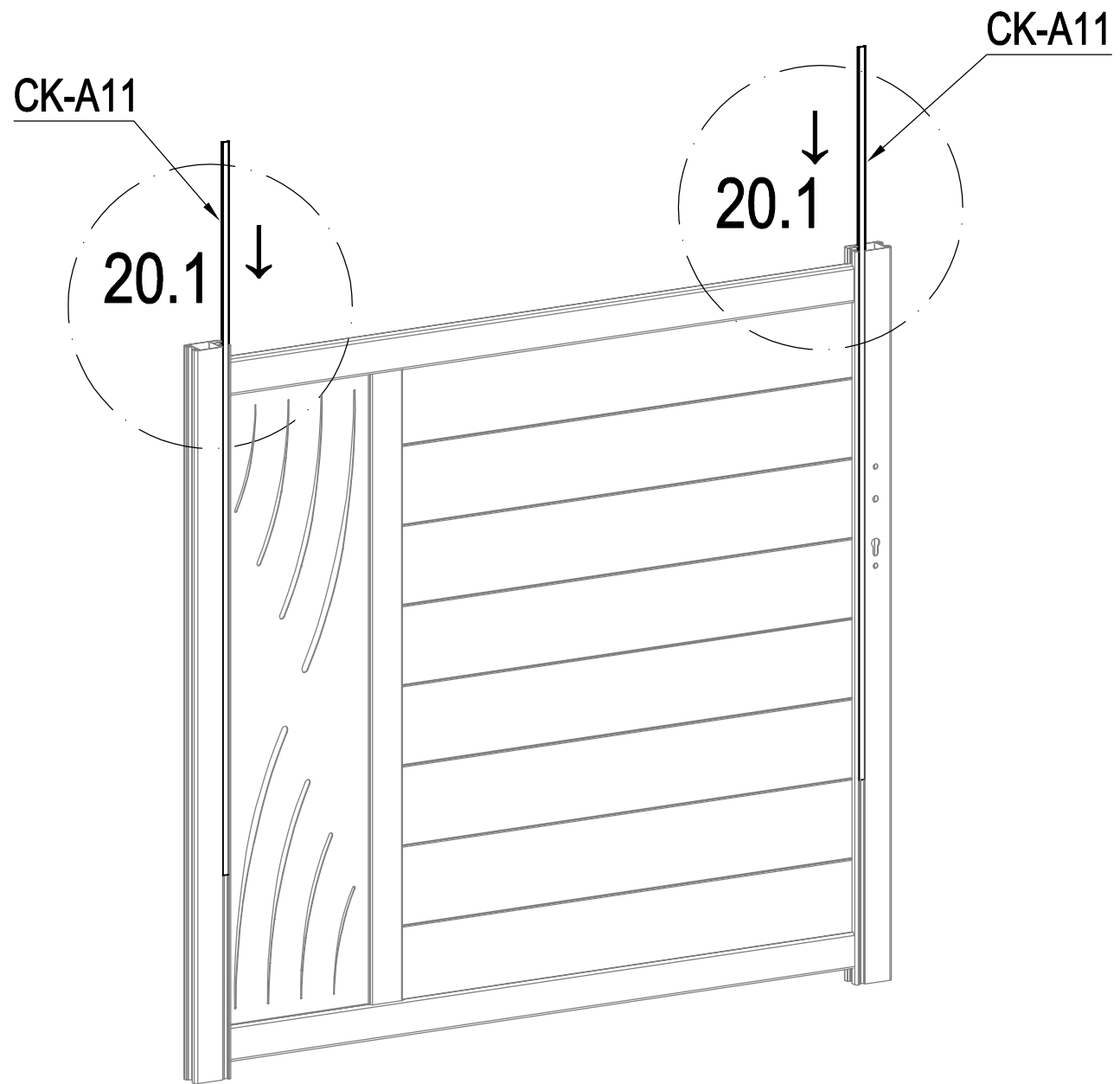

	CK-A11	2
---	--------	---

A

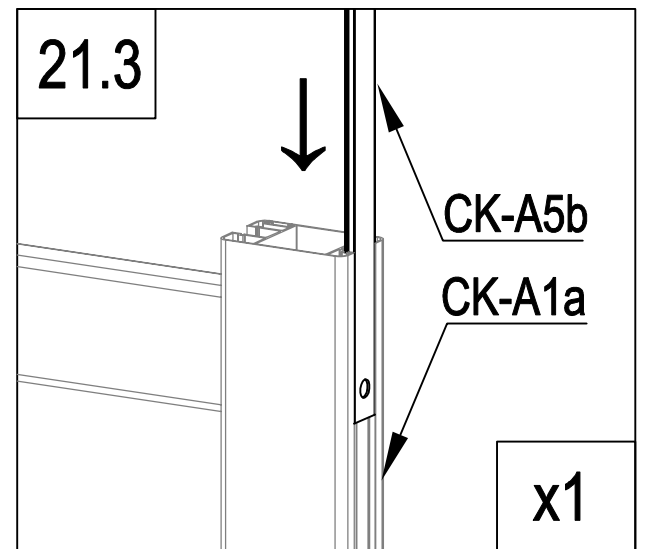
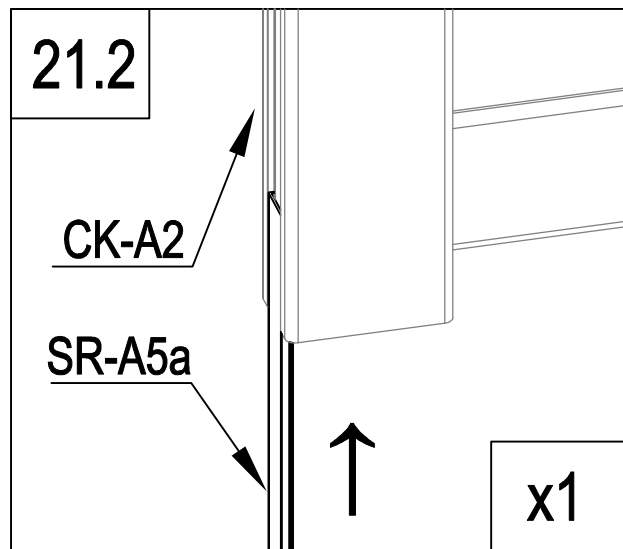
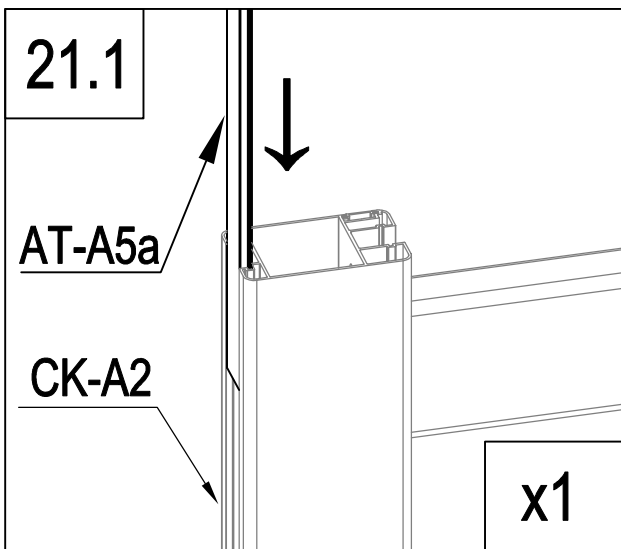
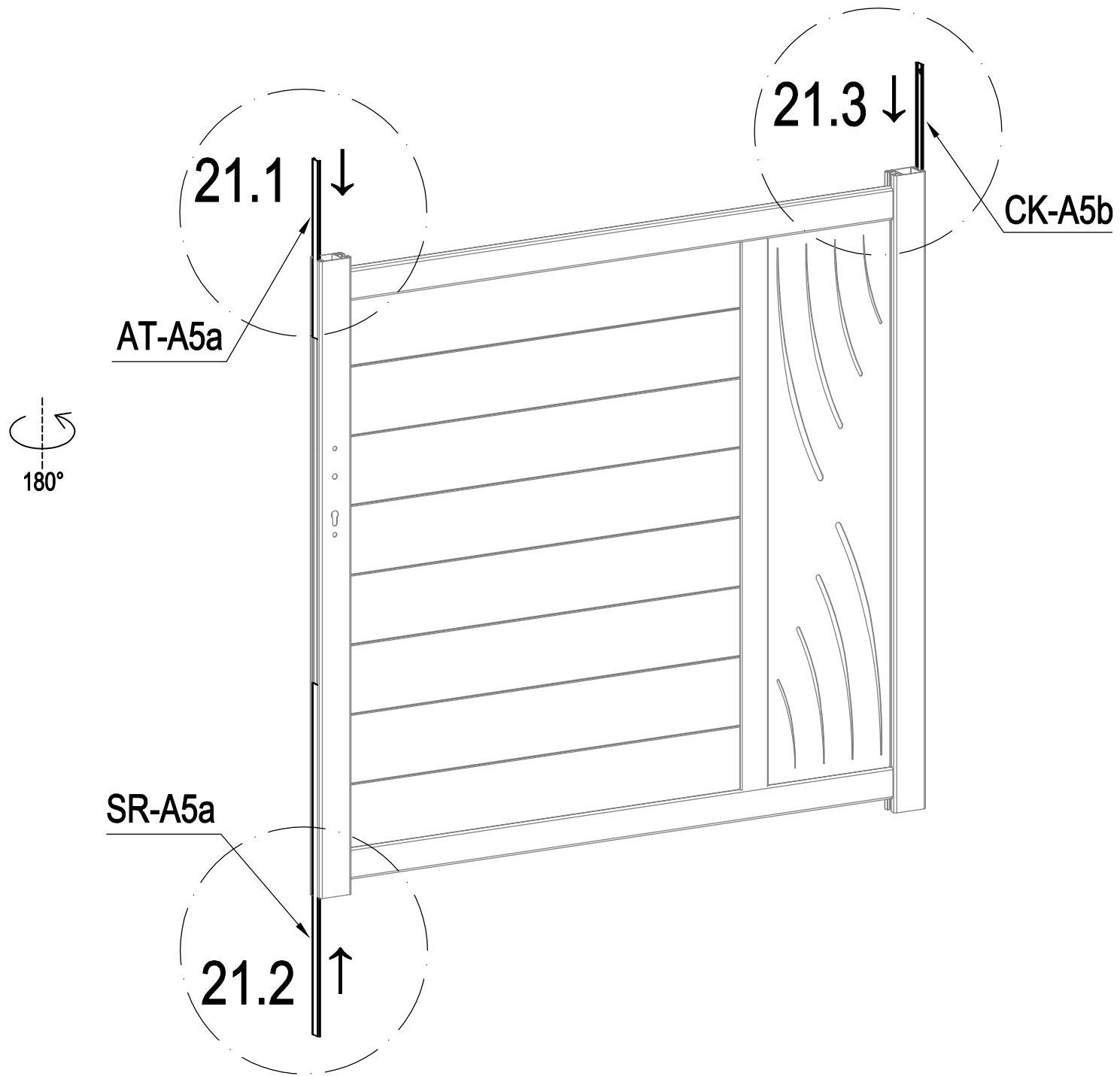

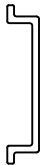

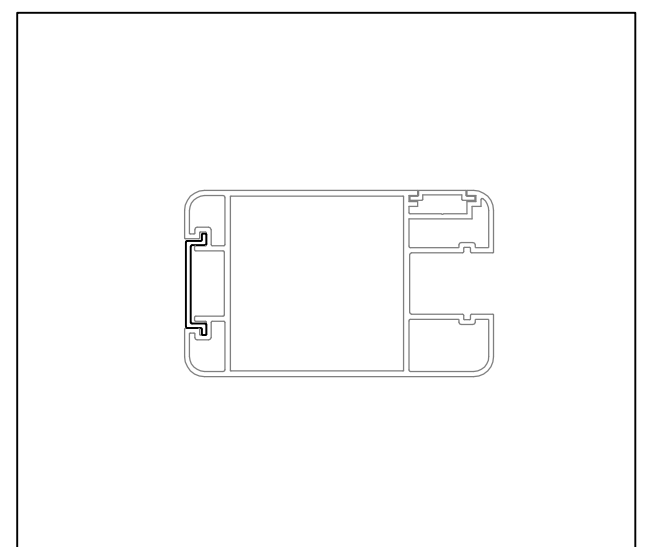
	CK-A5b	1
	AT-A5a	1
	SR-A5a	1



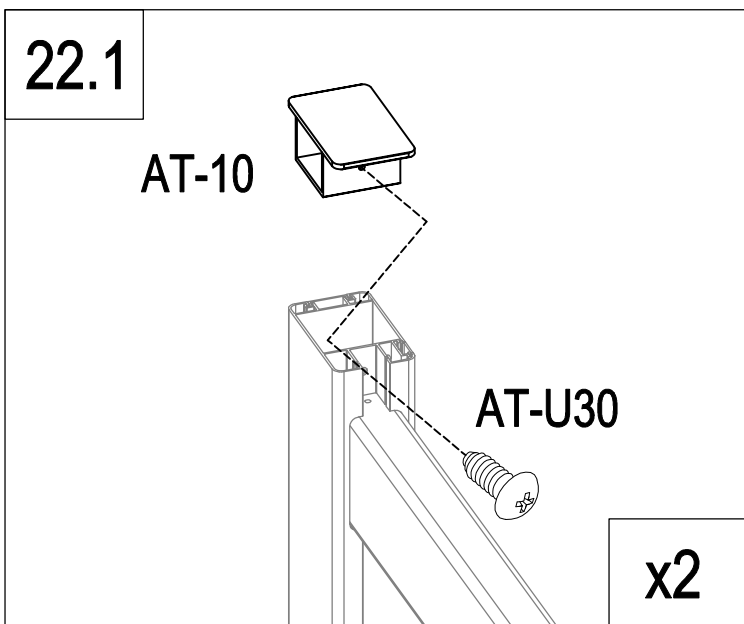
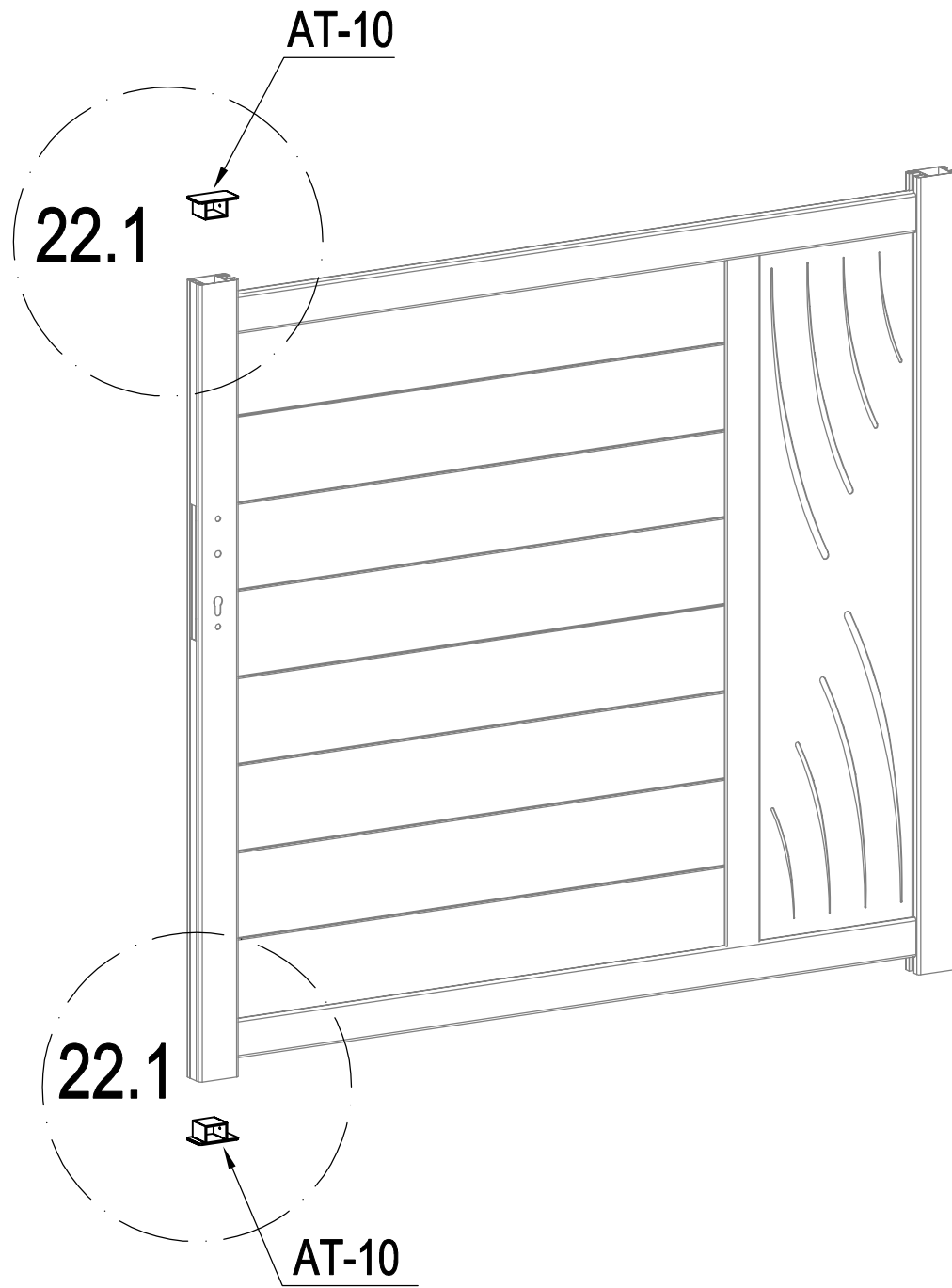

A

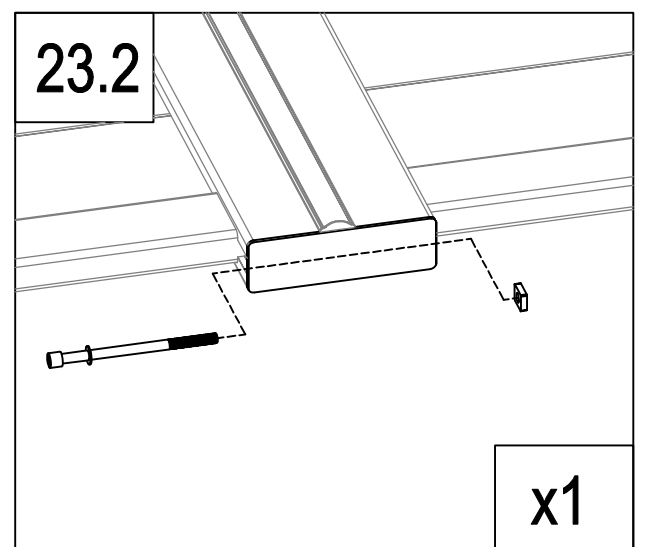
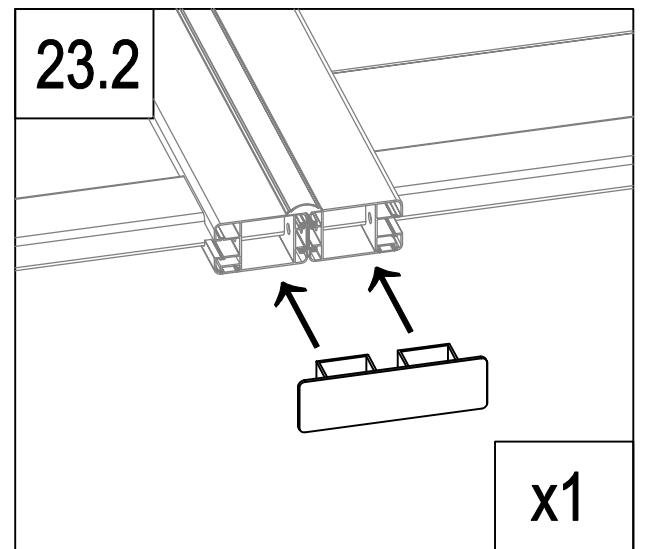
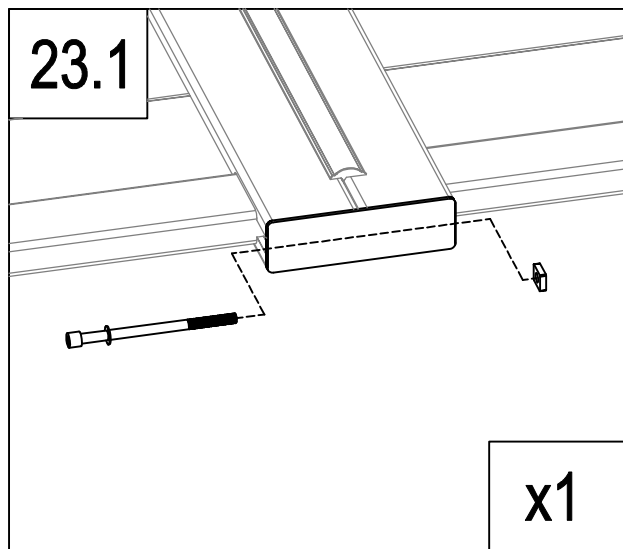
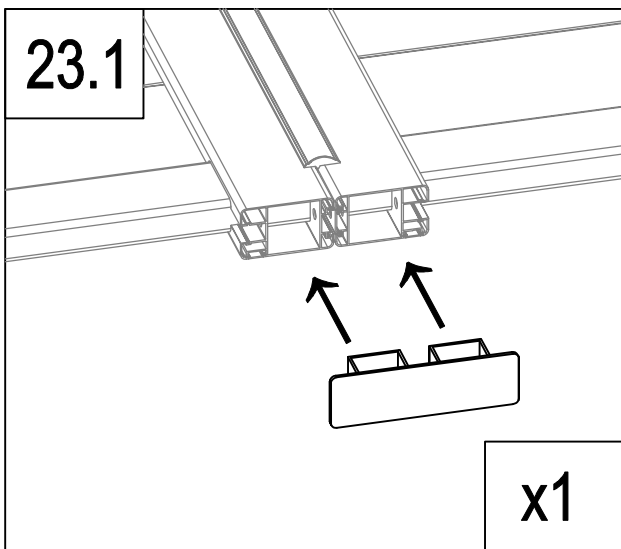
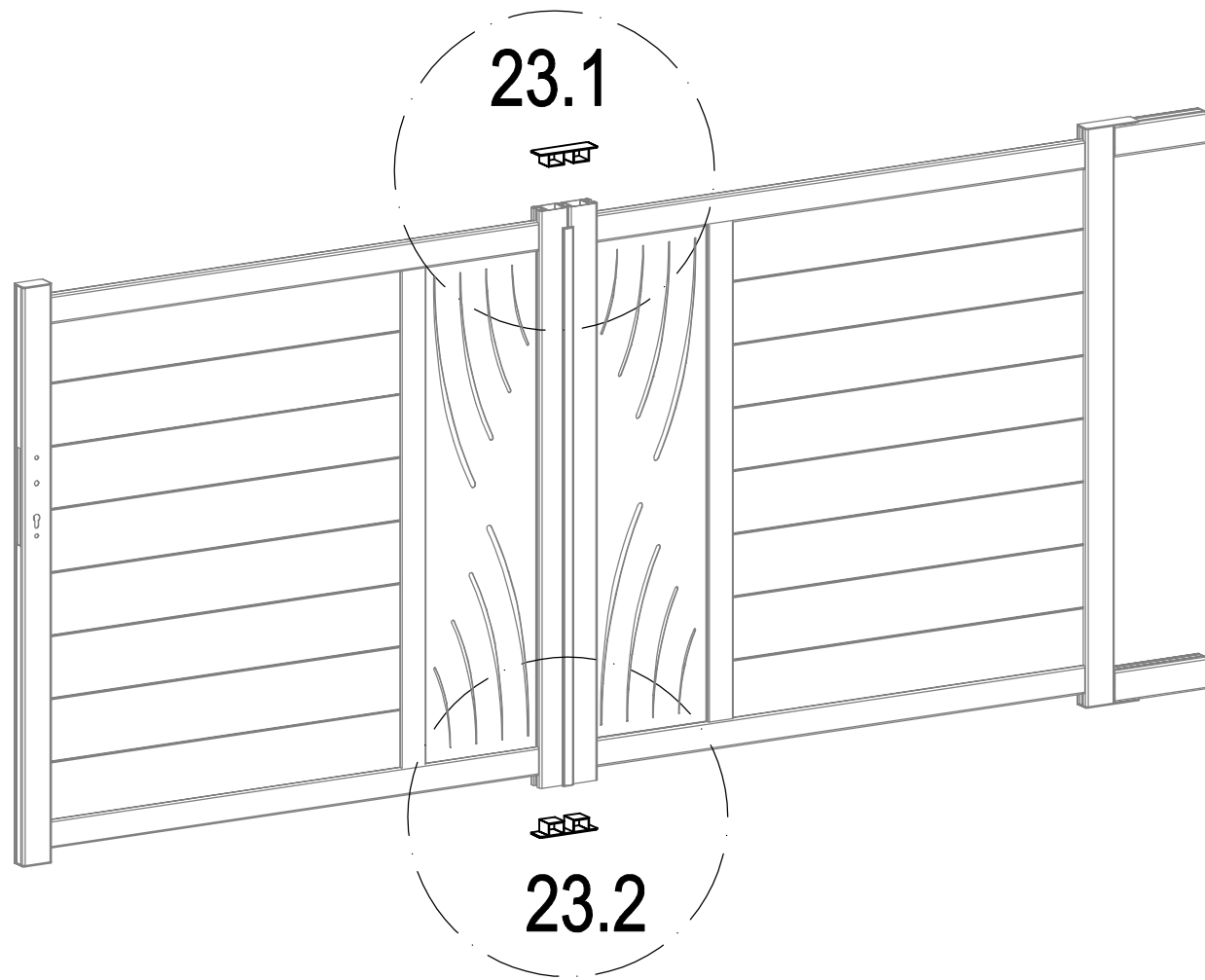

	AT-10	2
	AT-U30	2

A

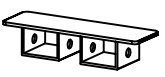

	AT-17	2
	AT-U33	2

A

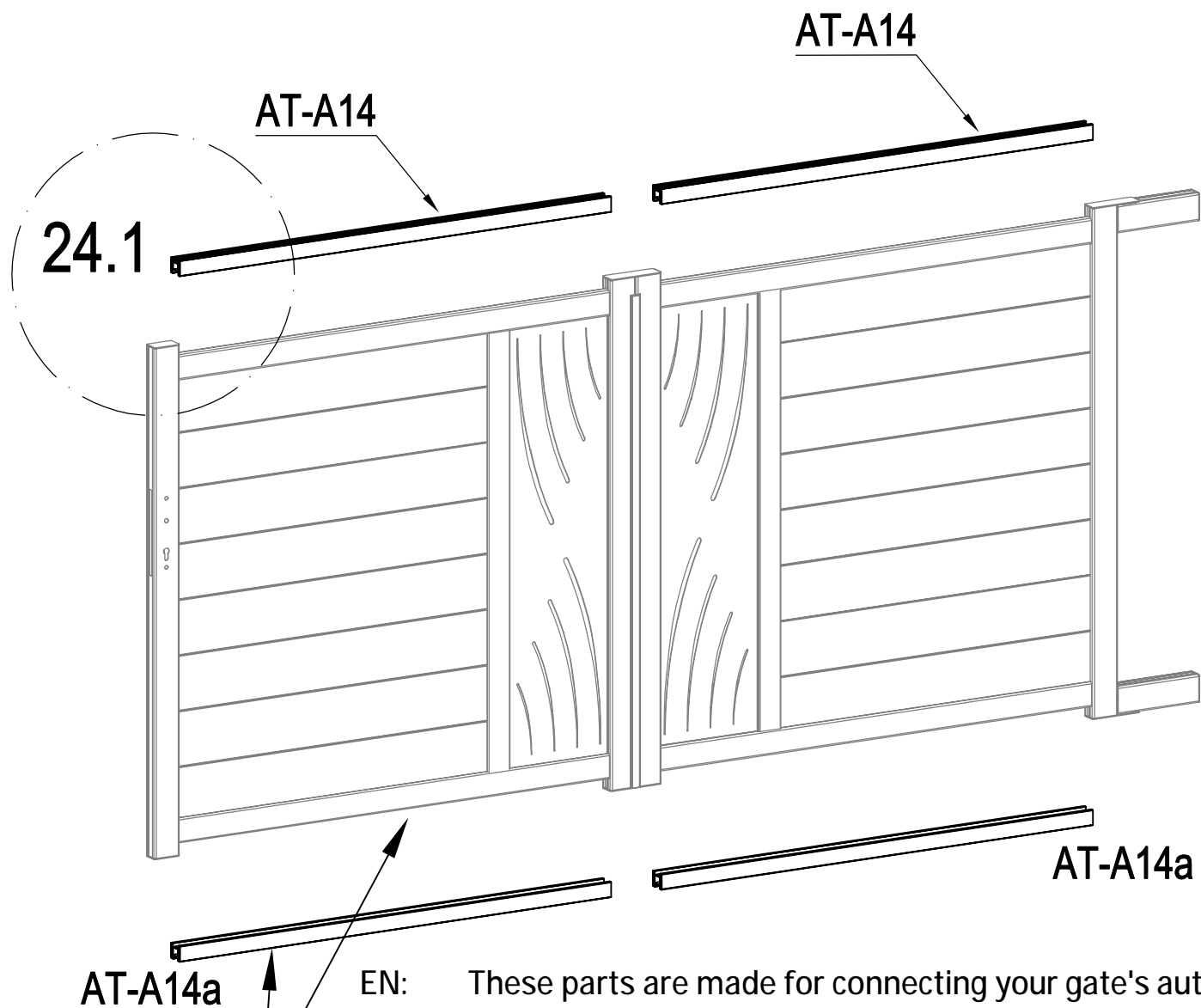



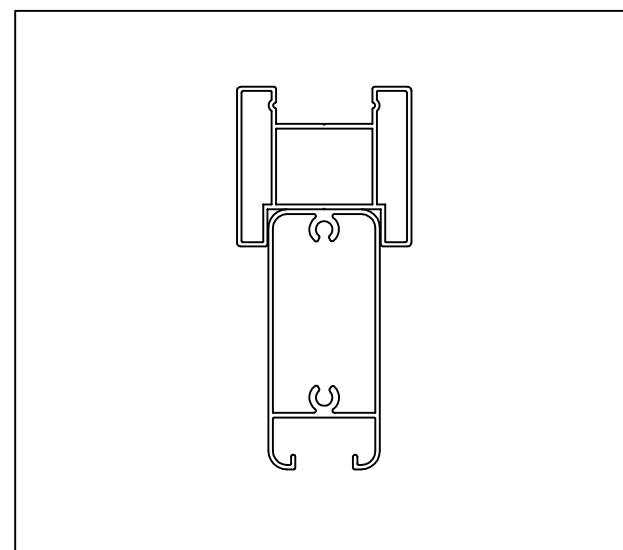
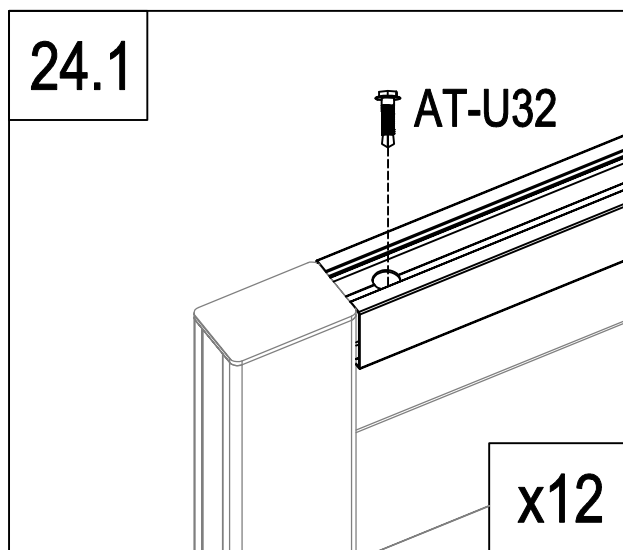
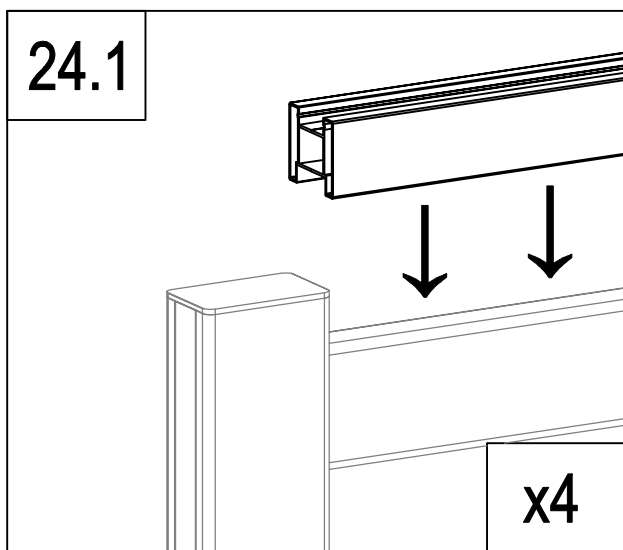

EN: These parts are made for connecting your gate's automation
 FR: Ces pièces sont faites pour relier l'automatisation de votre portail
 DE: Diese Teile sind für den Anschluss der Automatisierung Ihres Tores vorgesehen
 ES: Estas piezas están hechas para conectar la automatización de su puerta
 PT: Estas peças são feitas para ligar a automatização do seu portão
 IT: Queste parti sono realizzate per collegare l'automazione del vostro cancello
 NL: Deze onderdelen zijn gemaakt voor het aansluiten van de automatisering van uw poort.
 PL: Te części są wykonane do podłączenia automatyki bramy.

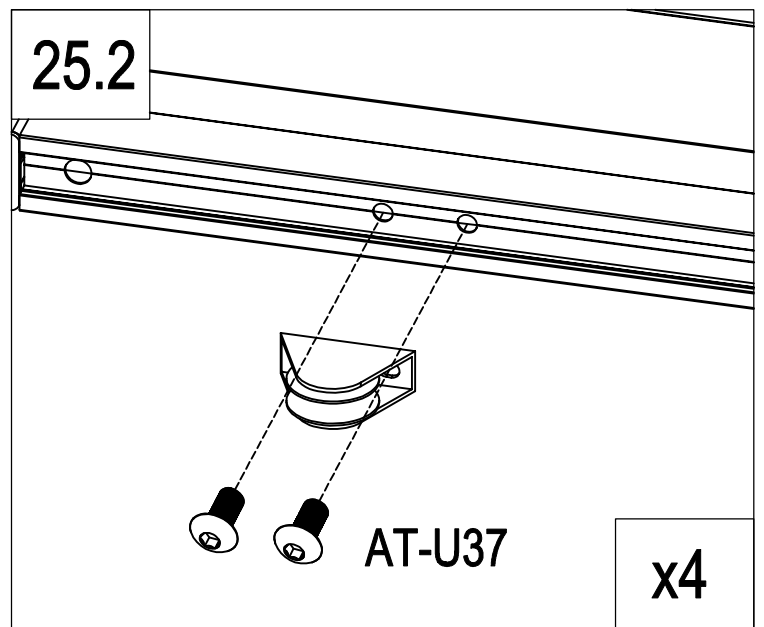
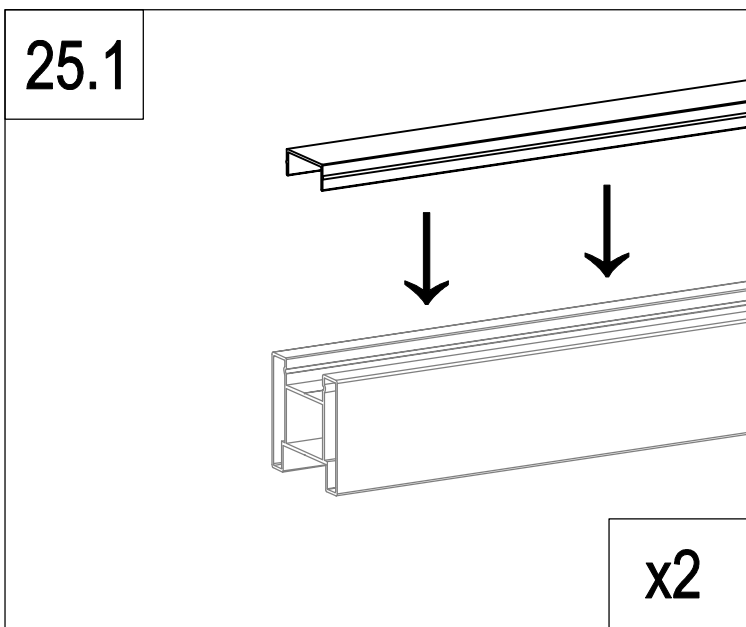
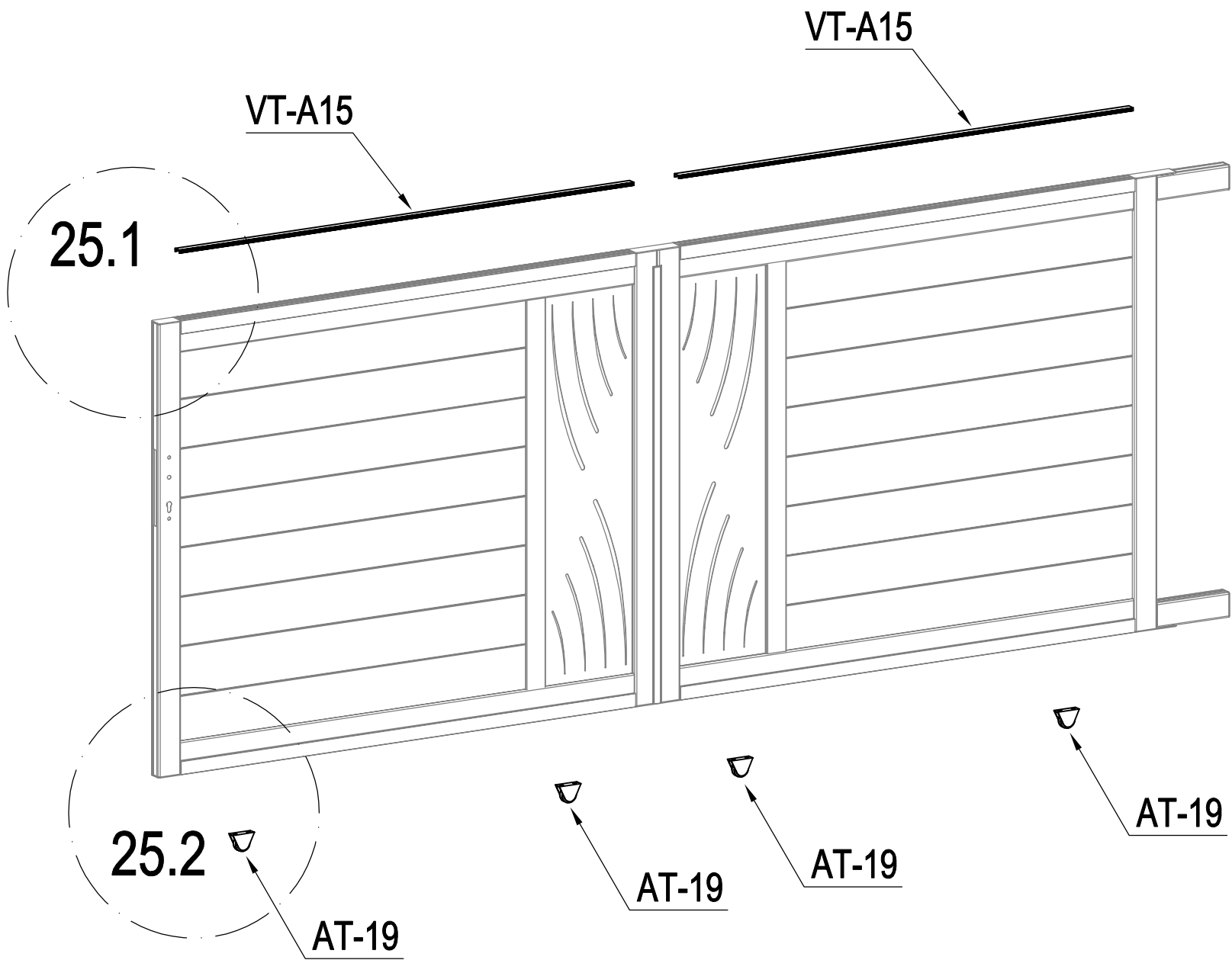

	AT-A14	2
	AT-A14a	2
	AT-U32	12



A

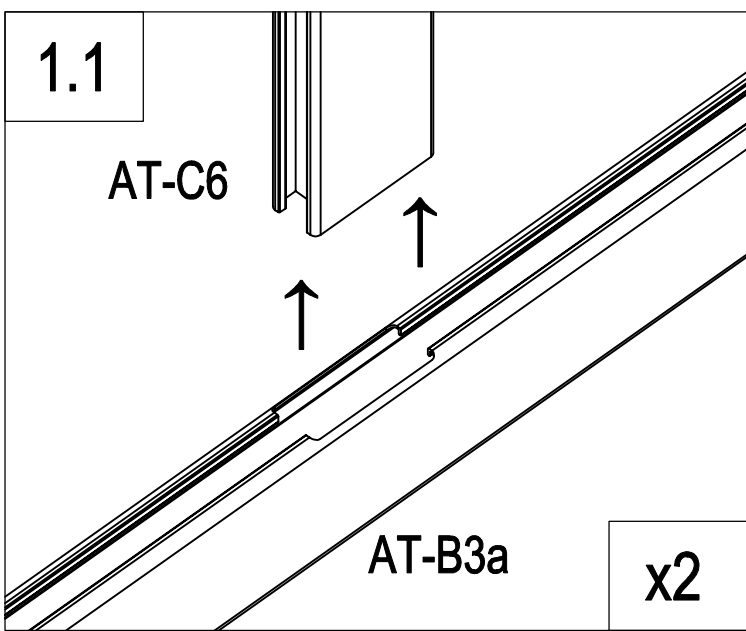
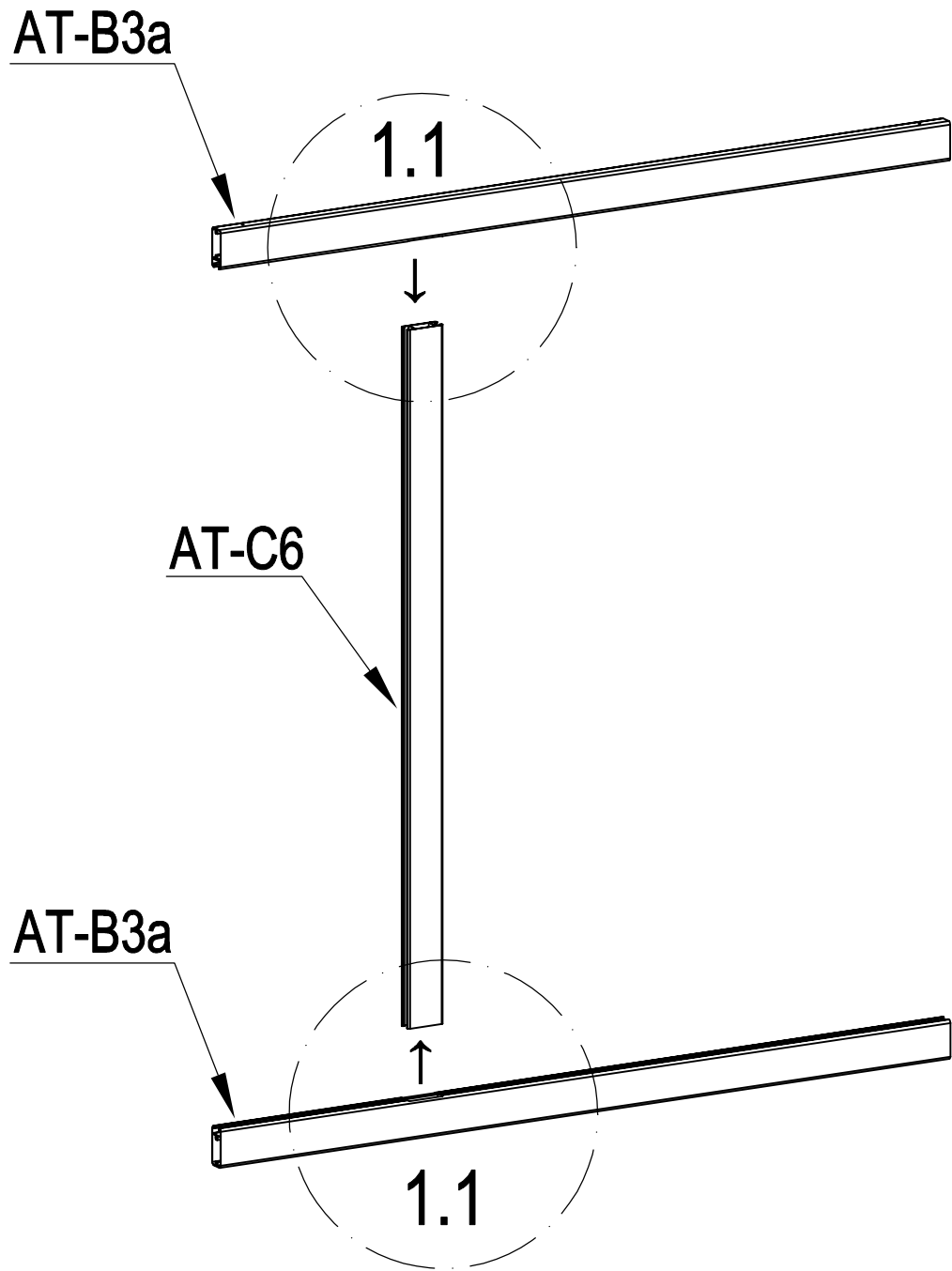

	VT-A15	2
	AT-19	4
	AT-U37	8

B



	AT-C6	1
	AT-B3a	2

B

EN :you can flip and switch the direction of this plate to personalize your gate

FR: vous pouvez retourner et changer la direction de cette plaque pour personnaliser votre portail

DE: Sie können dieses Schild umdrehen und die Richtung wechseln, um Ihr Tor zu personalisieren.

ES: puedes girar y cambiar la dirección de esta placa para personalizar tu puerta

PT: pode virar e mudar a direção desta placa para personalizar o seu portão

IT: potete capovolgere e cambiare la direzione di questa piastra per personalizzare il vostro cancello

NL: u kunt de richting van deze plaat omdraaien en veranderen om uw poort te verpersoonlijken...

PL: można obrócić i przełączyć kierunek tej płyty, aby spersonalizować bramę.

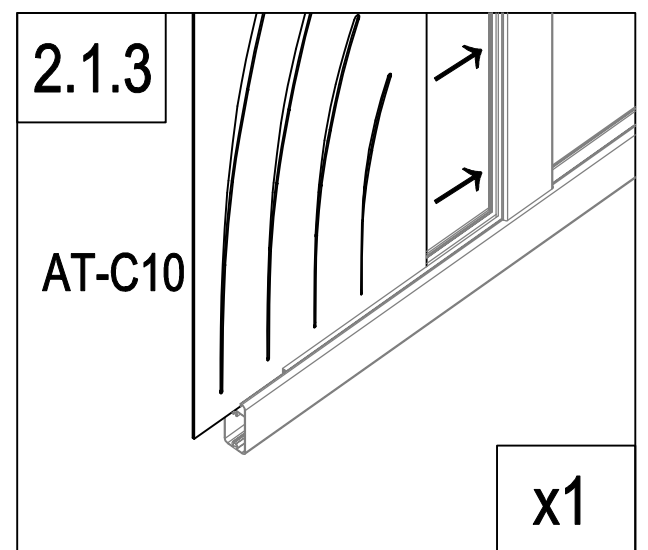
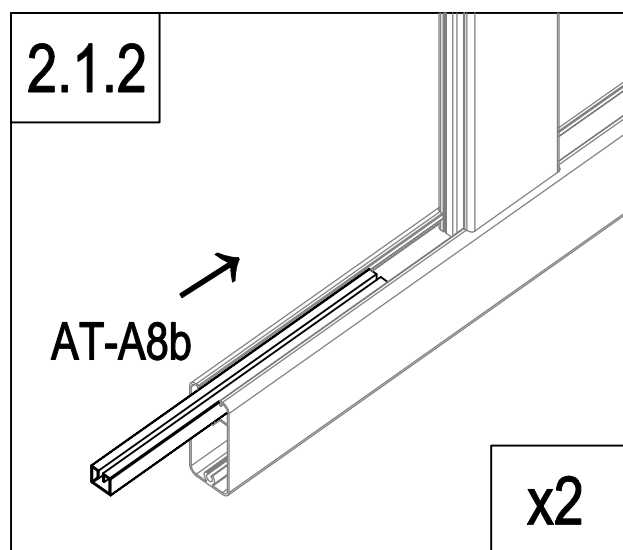
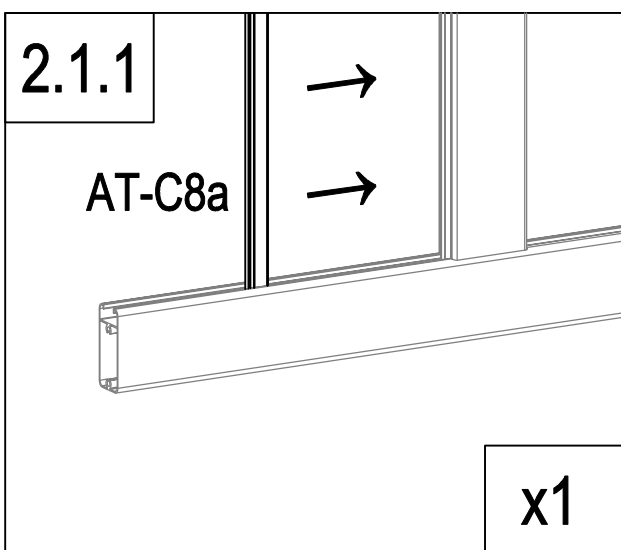
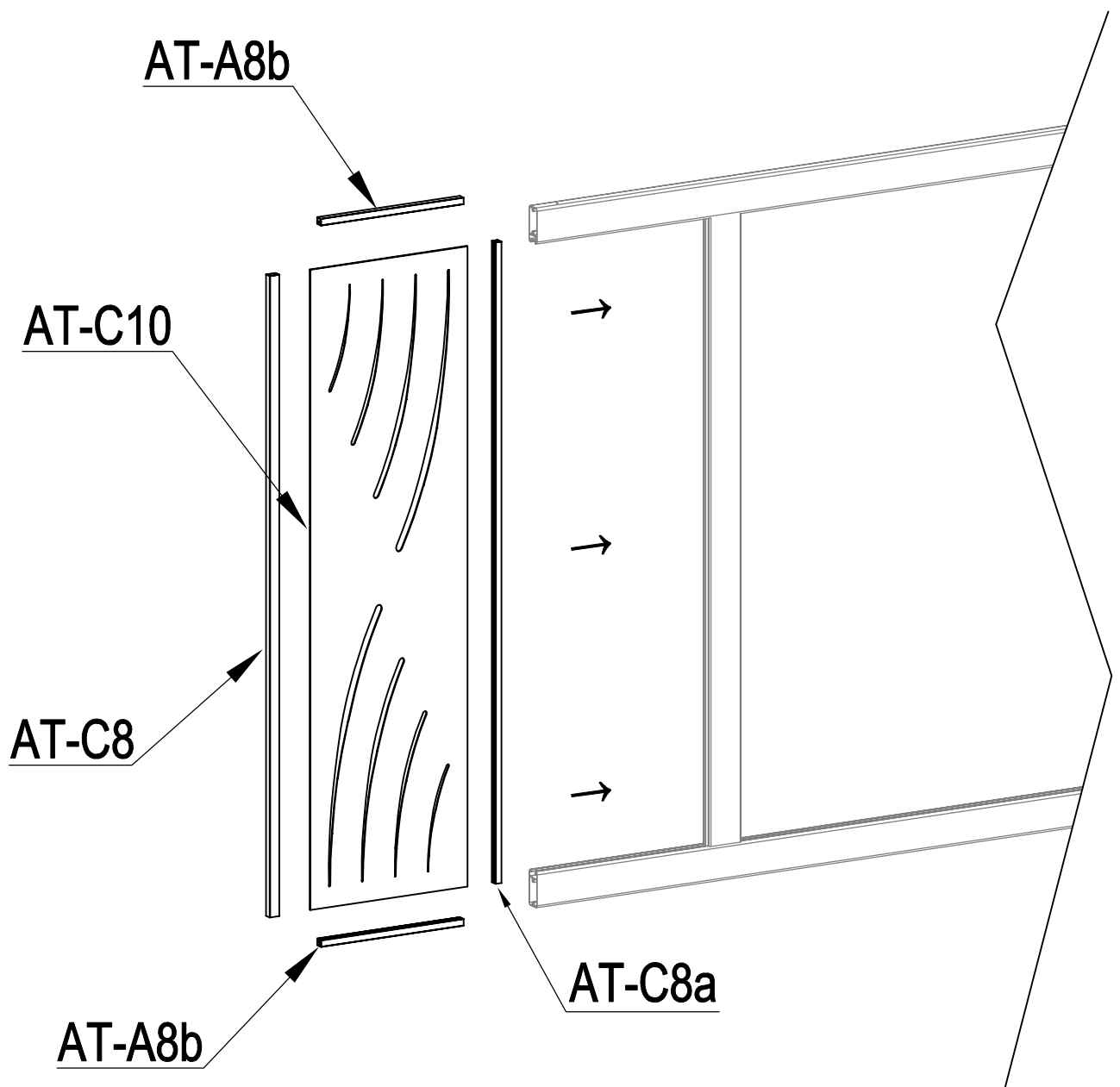

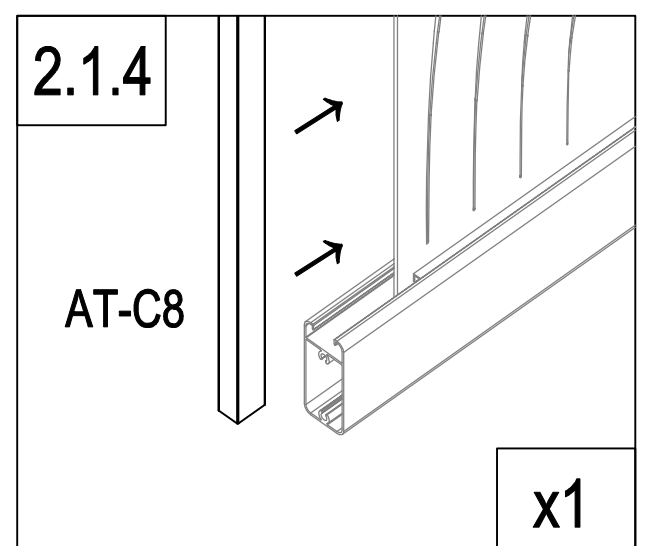

	AT-C8a	1
	AT-A8b	2
	AT-C10	1
	AT-C8	1

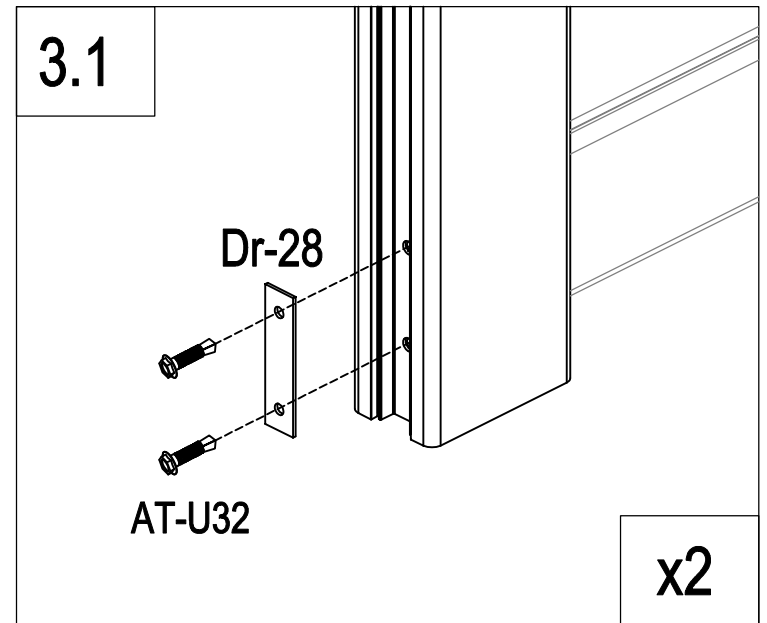
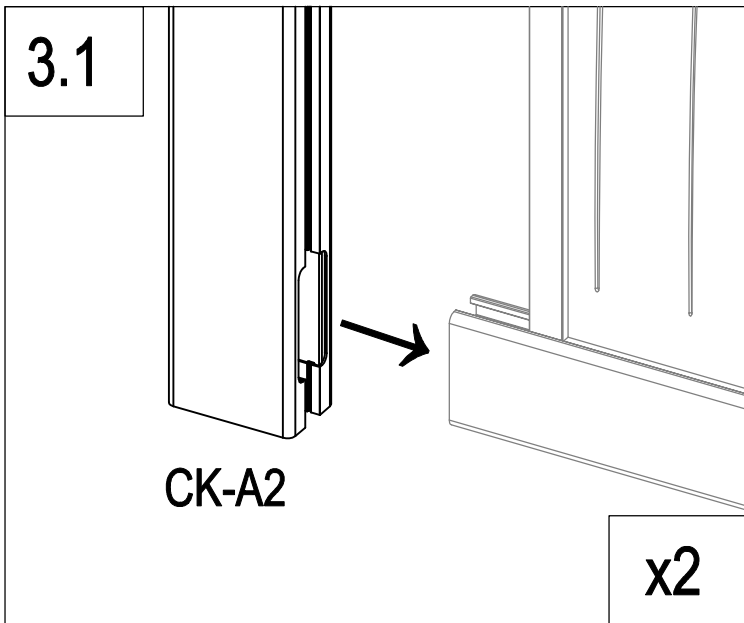
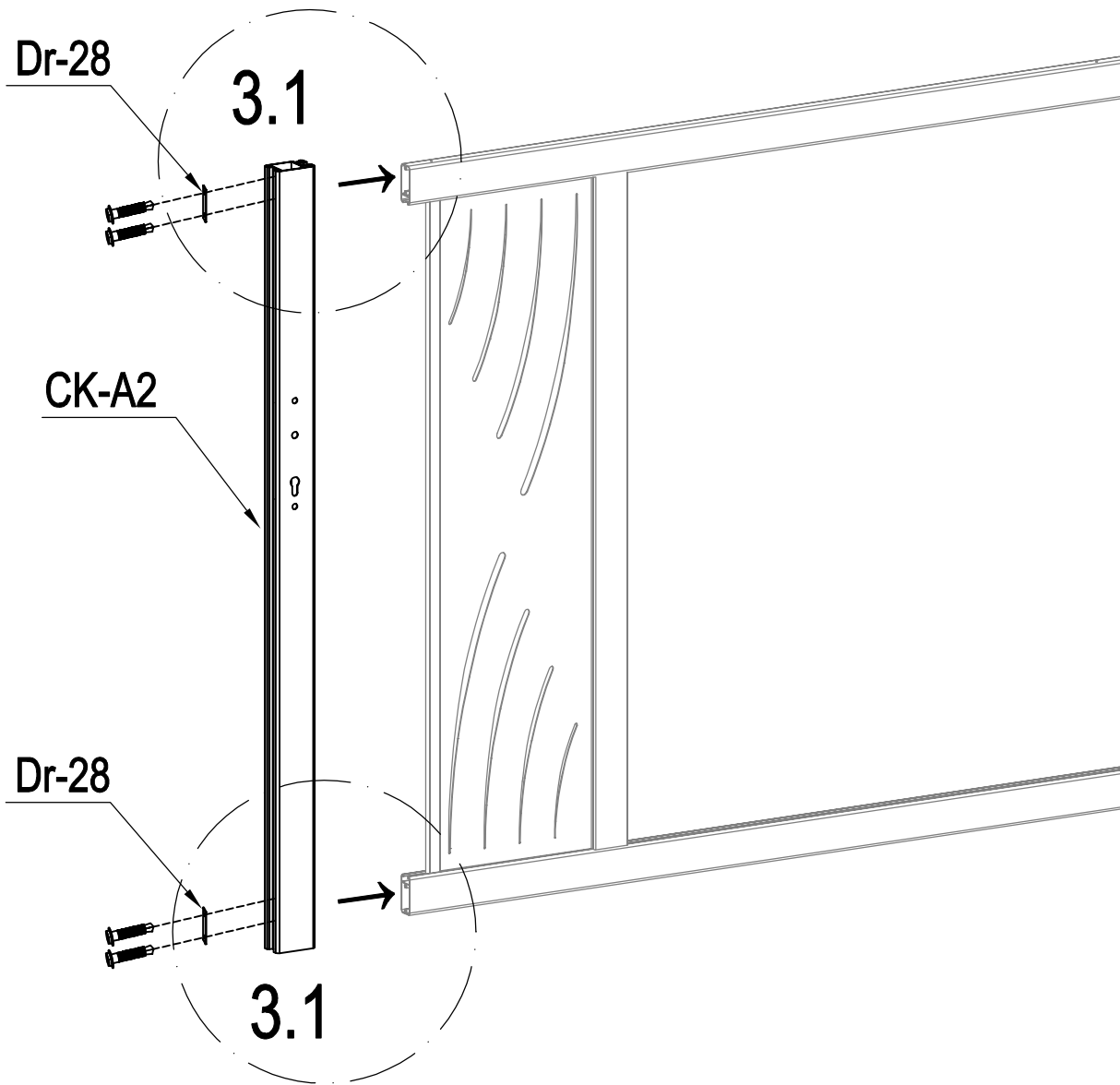

B

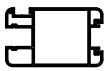

	CK-A2	1
	Dr-28	2
	AT-U32	4

B

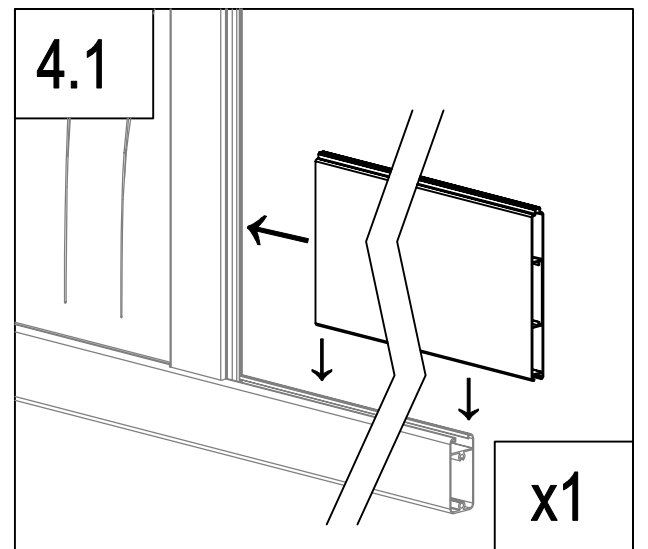
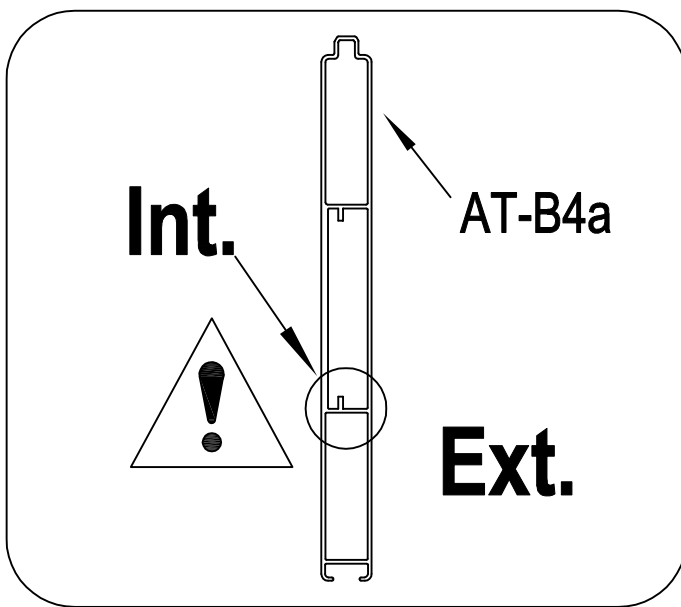
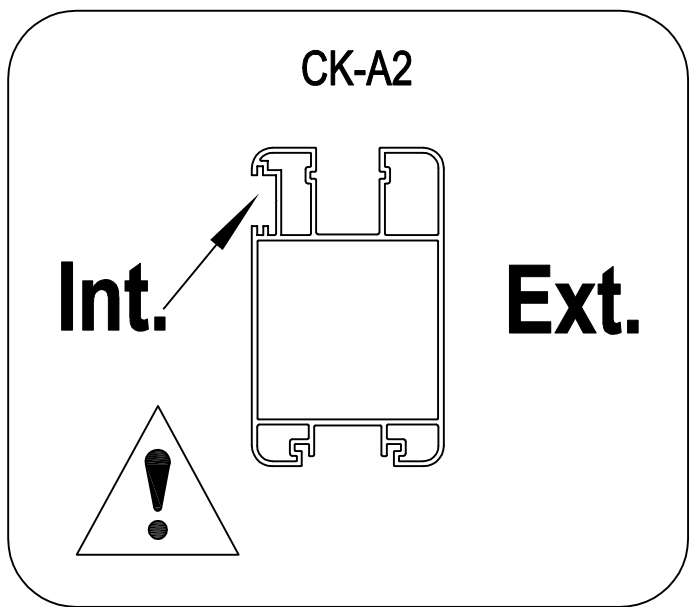
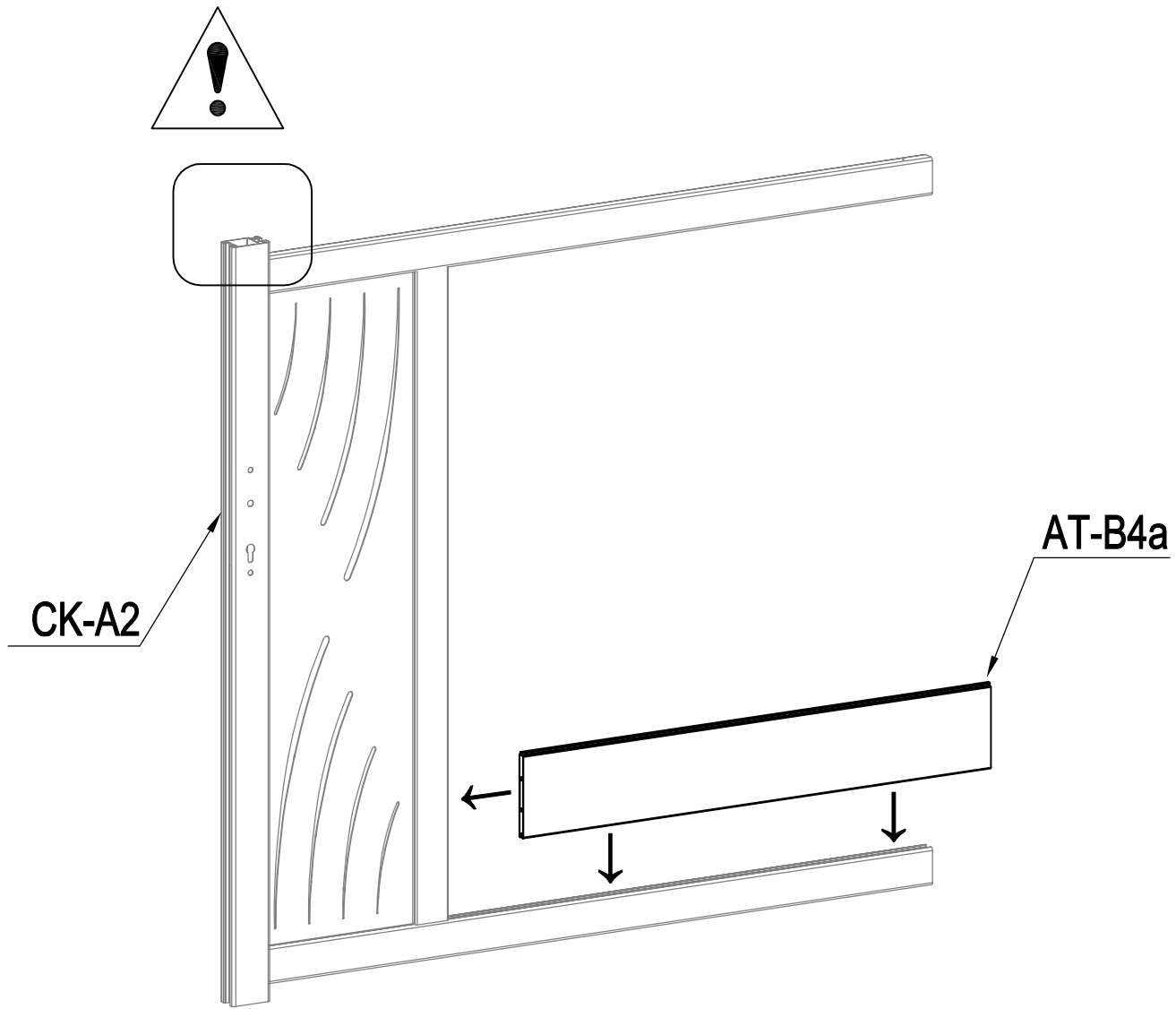

	AT-B4a	1
---	--------	---

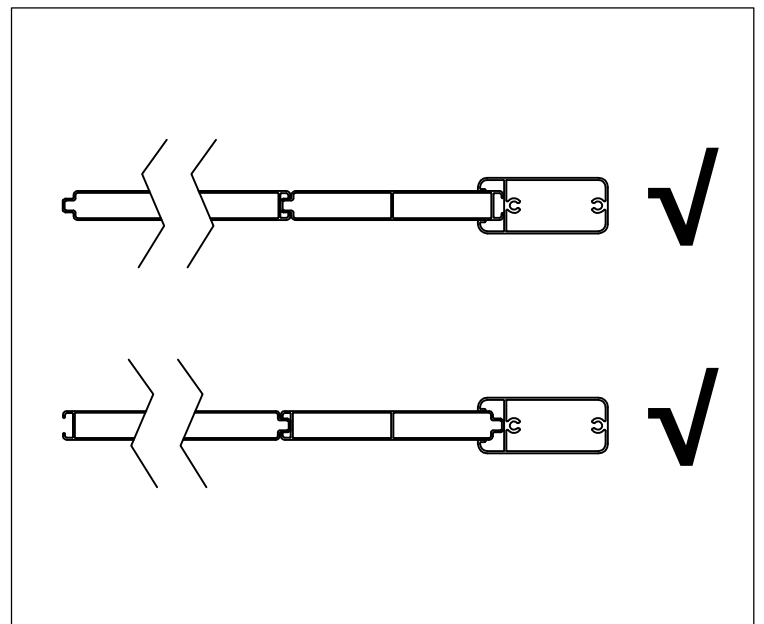
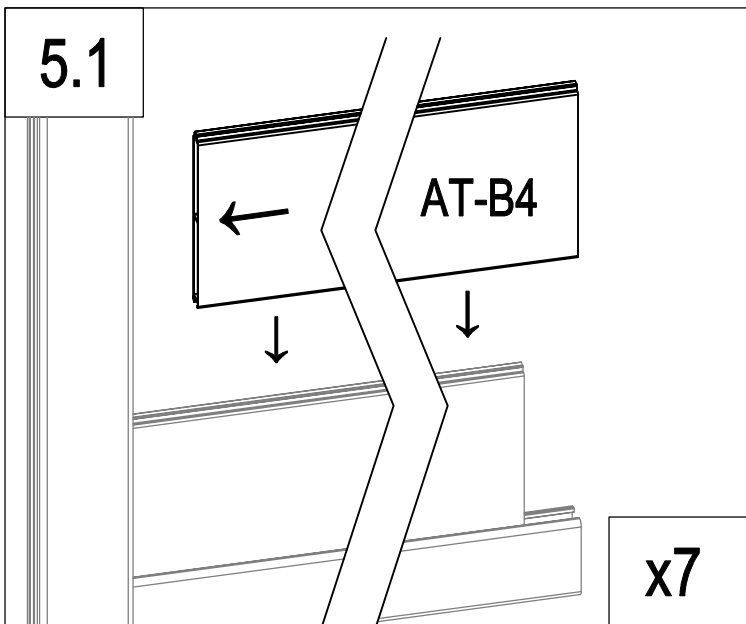
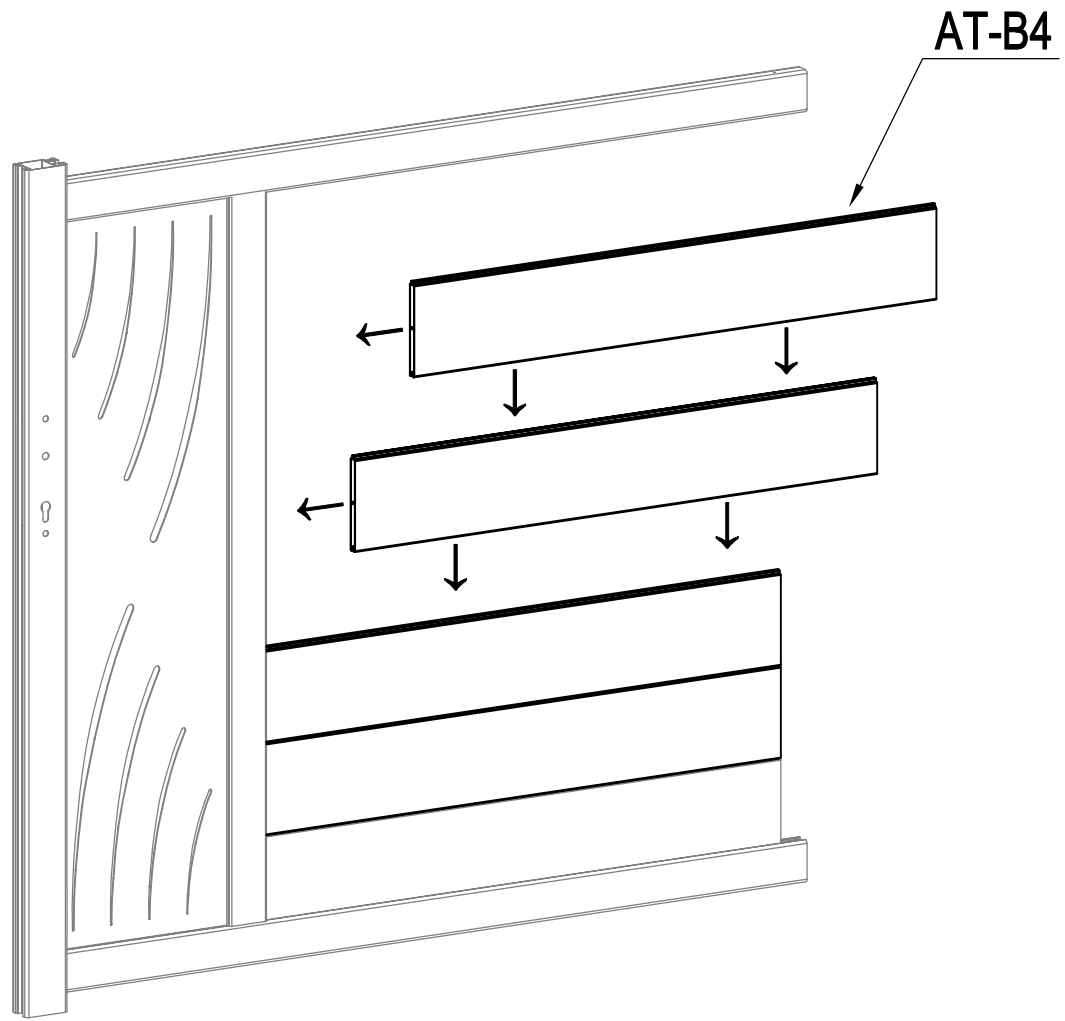

B

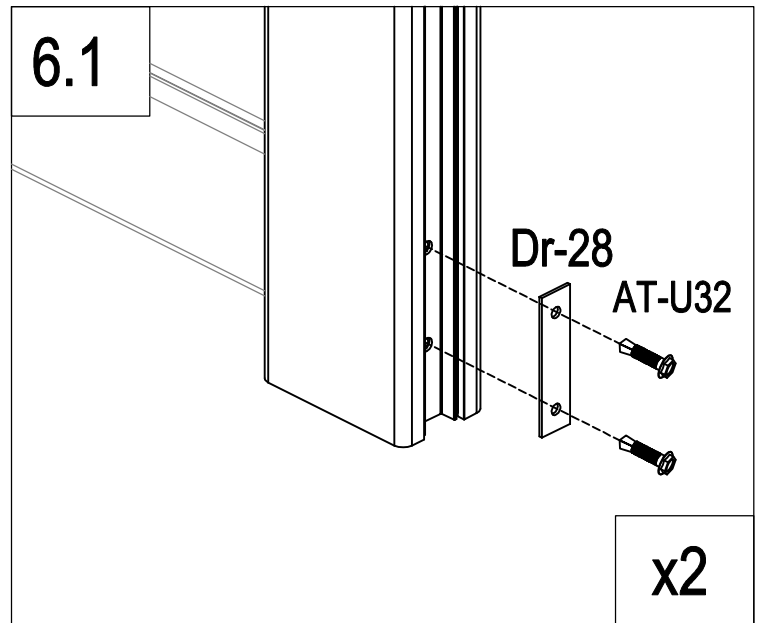
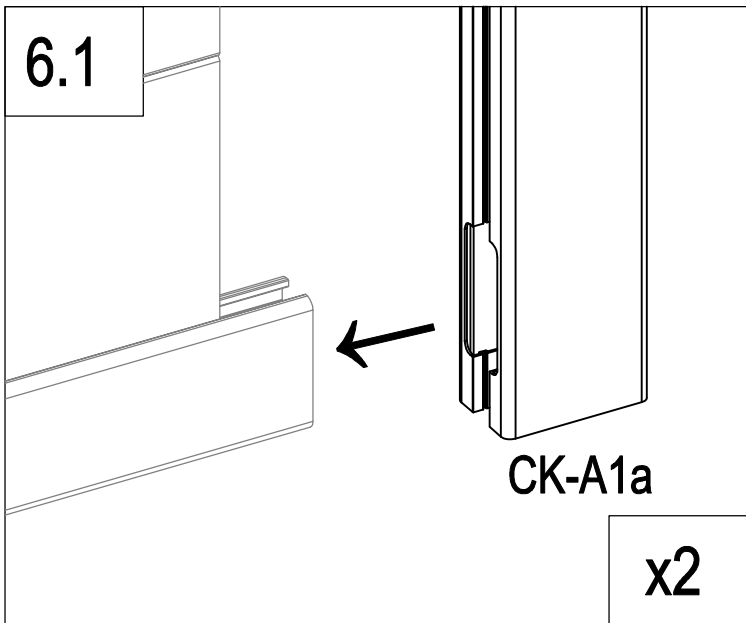
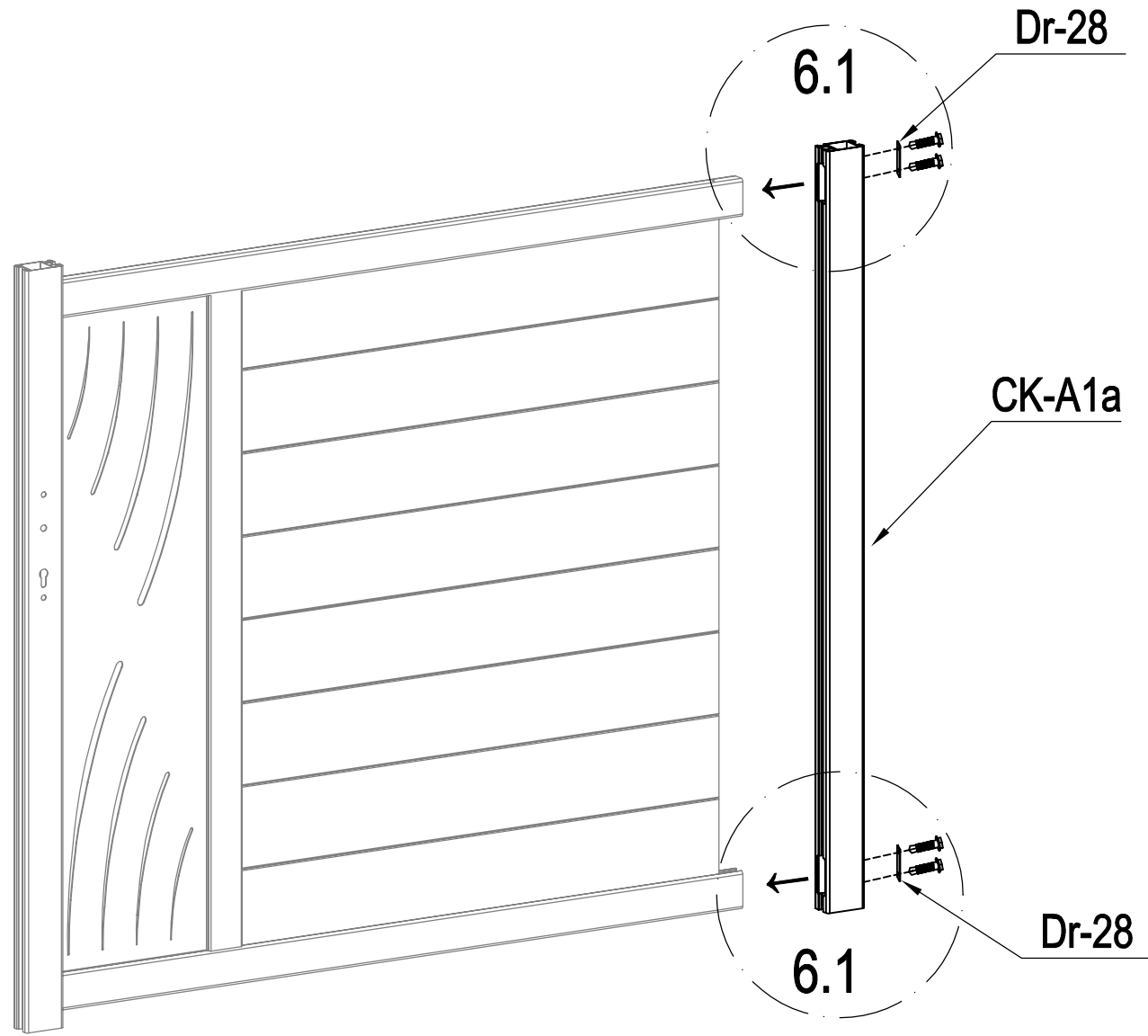

	AT-B4	7
---	-------	---

B

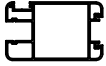

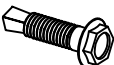
	CK-A1a	1
	Dr-28	2
	AT-U32	4

B

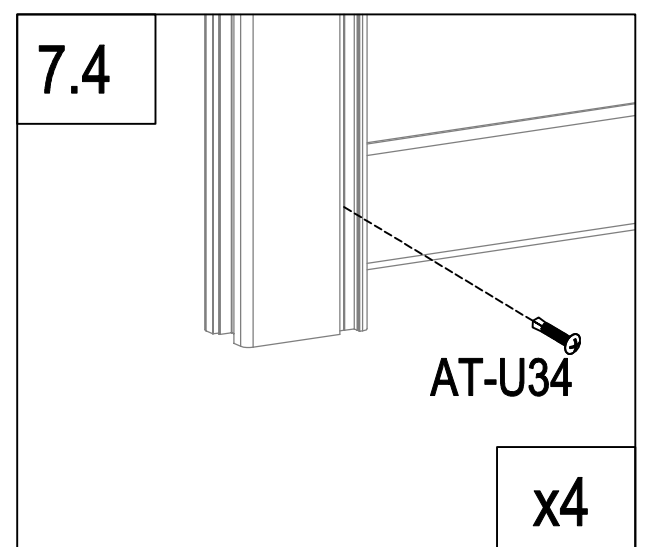
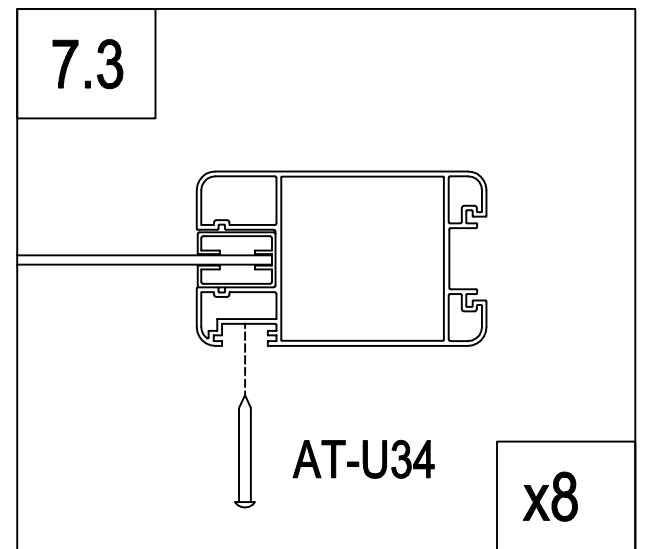
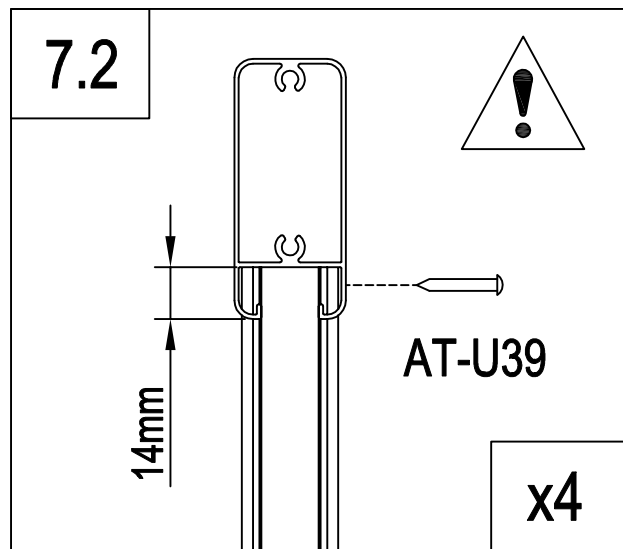
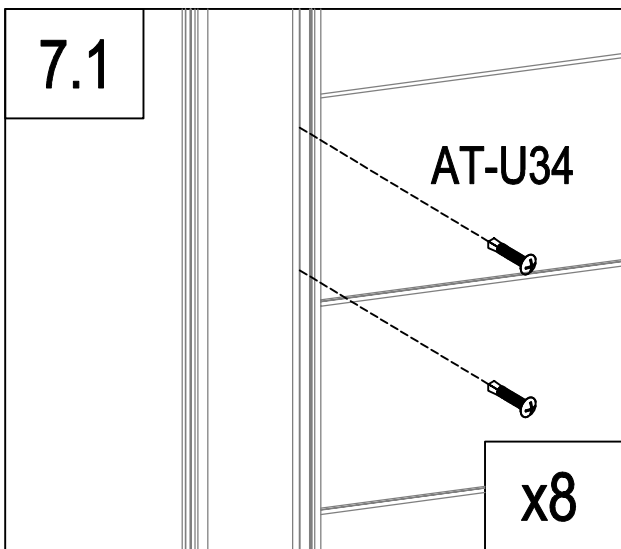
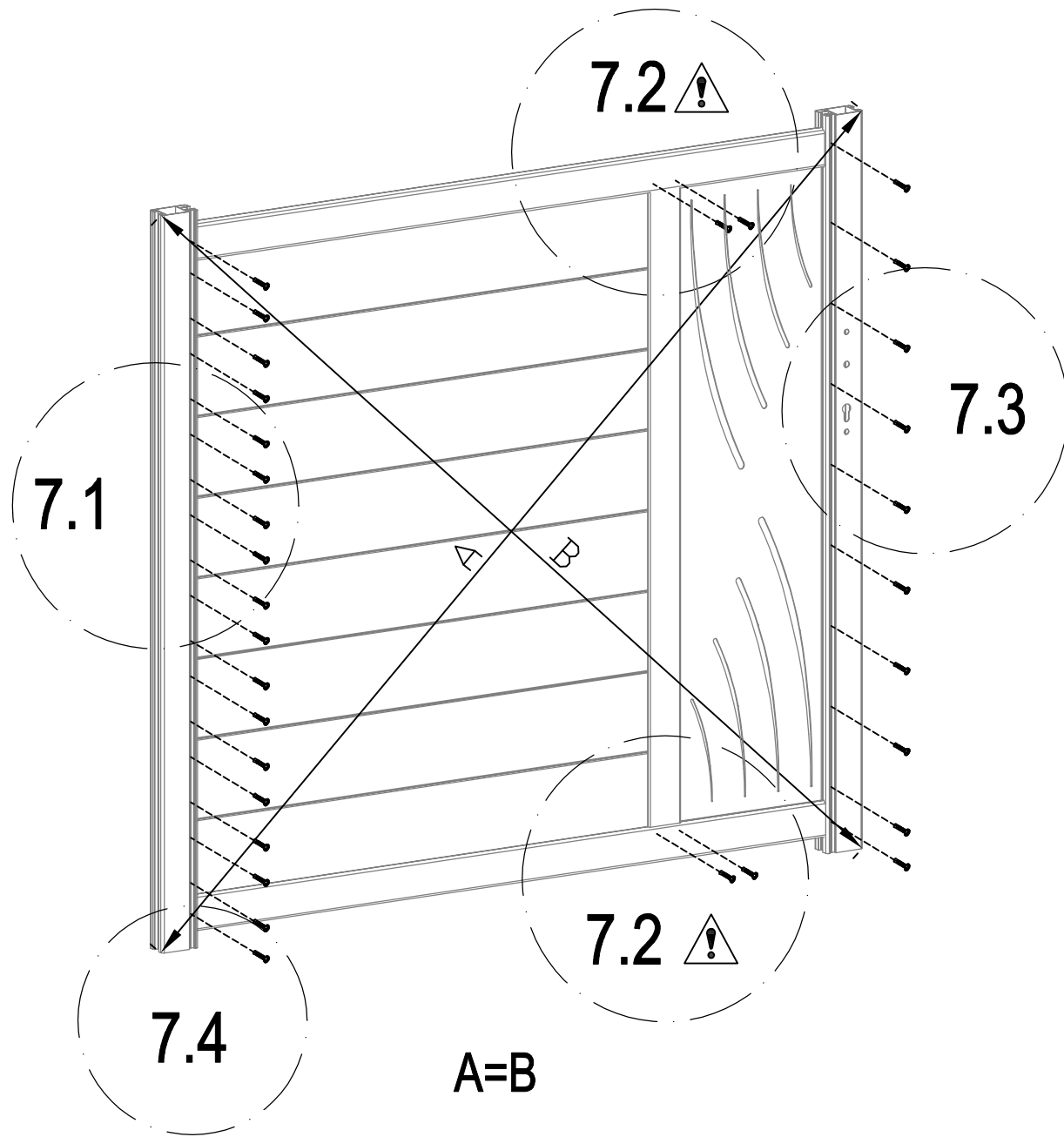
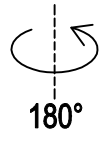

	AT-U34	28
	AT-U39	4

B

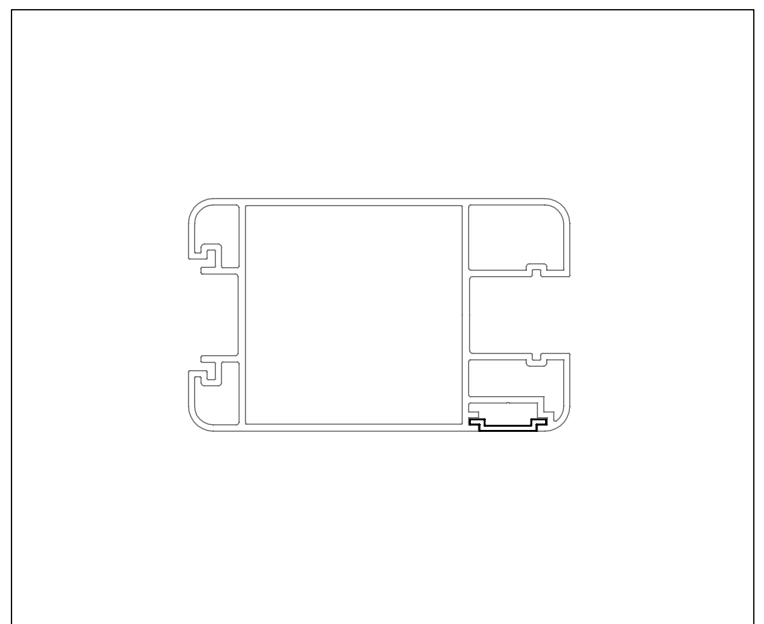
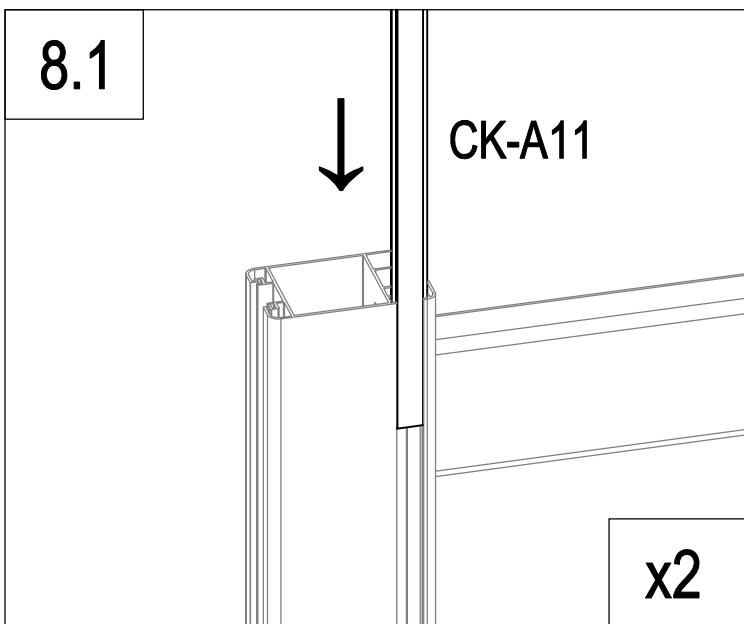
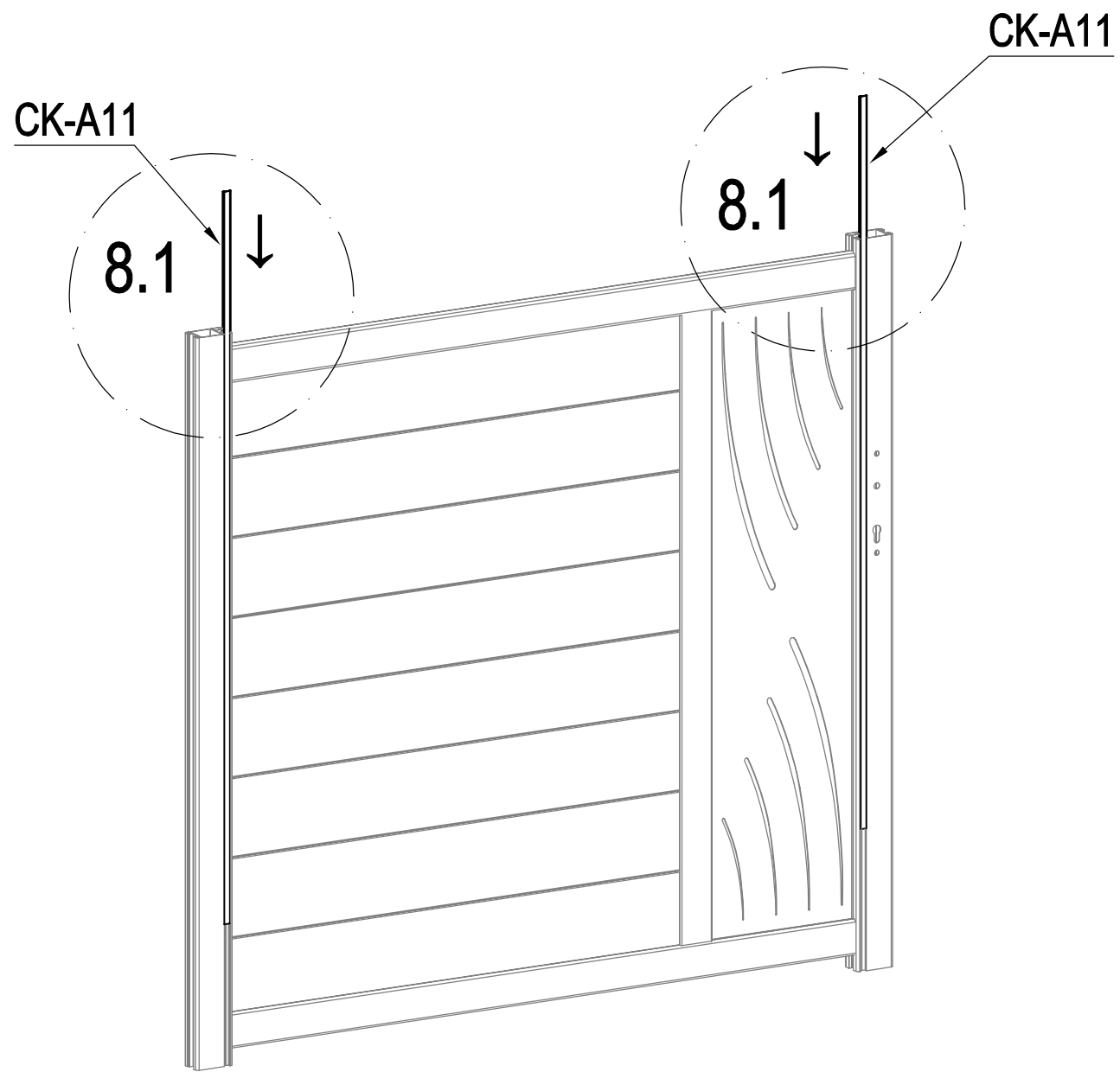

	CK-A11	2
---	--------	---

B

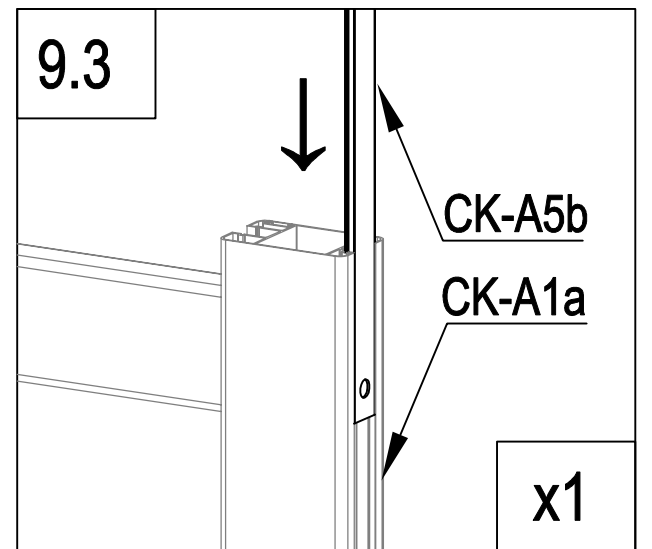
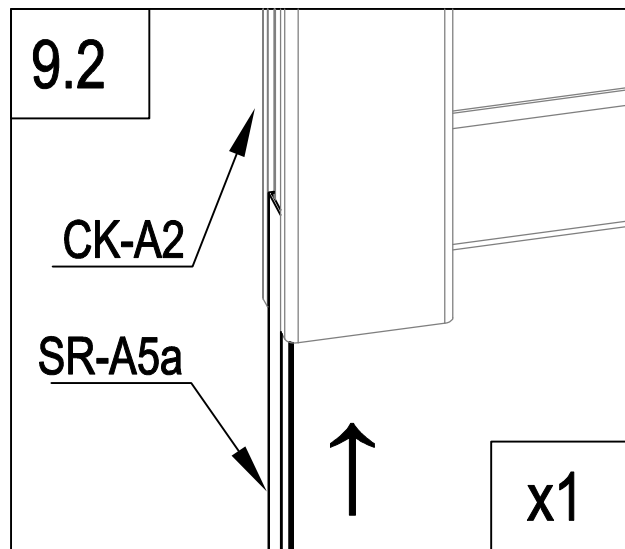
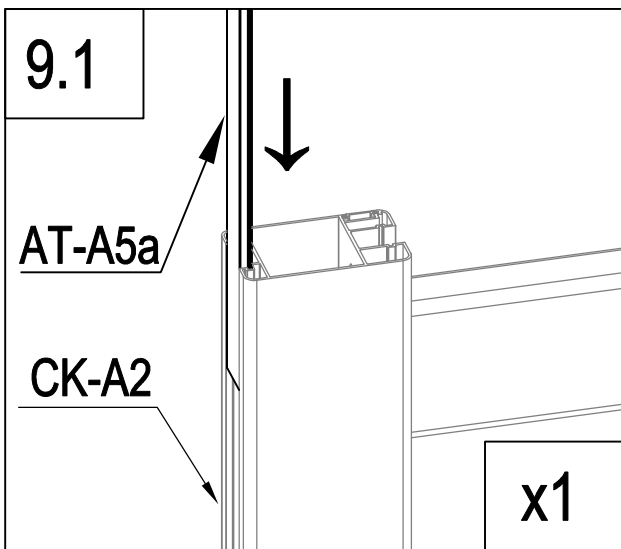
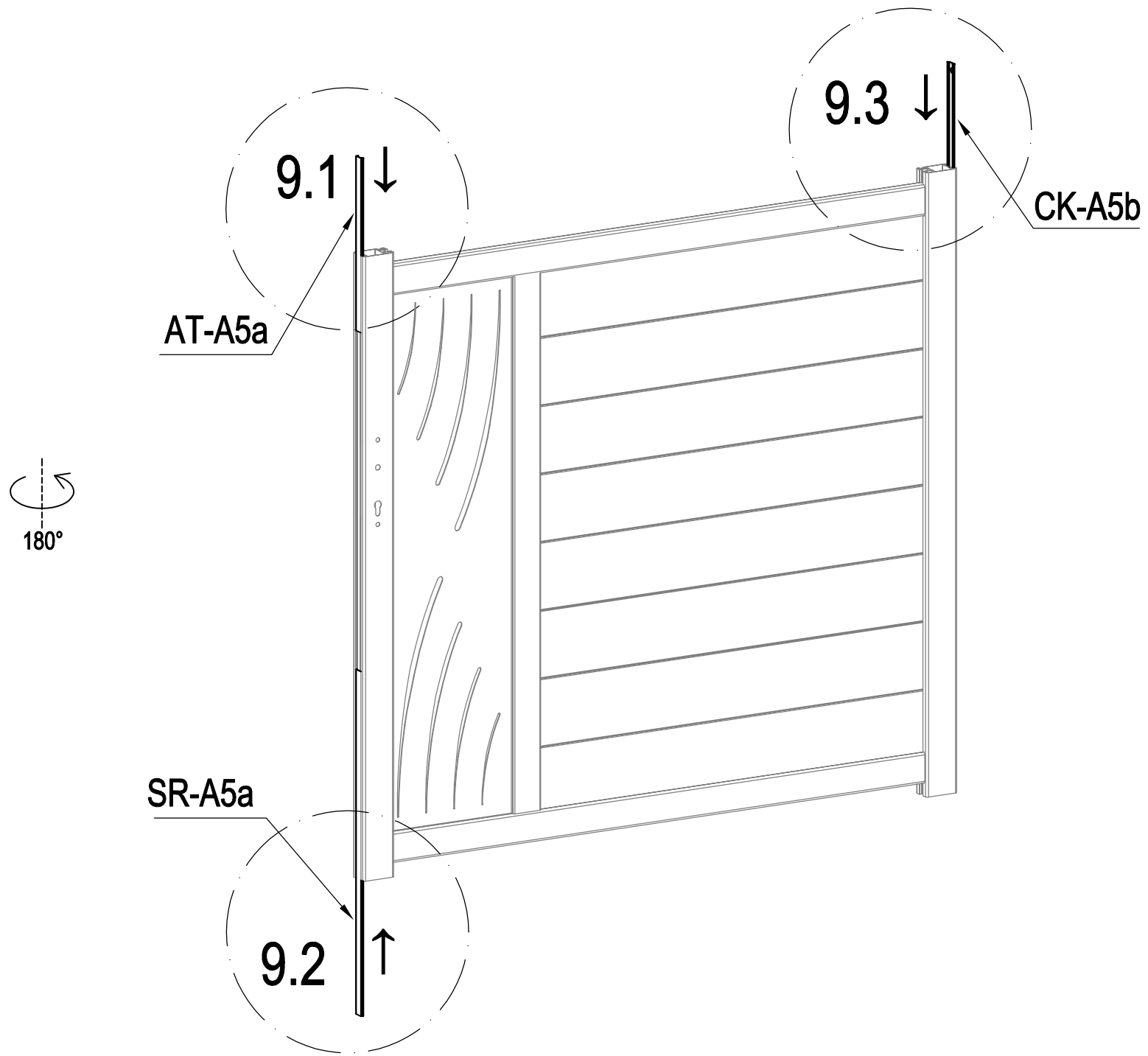

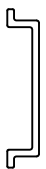

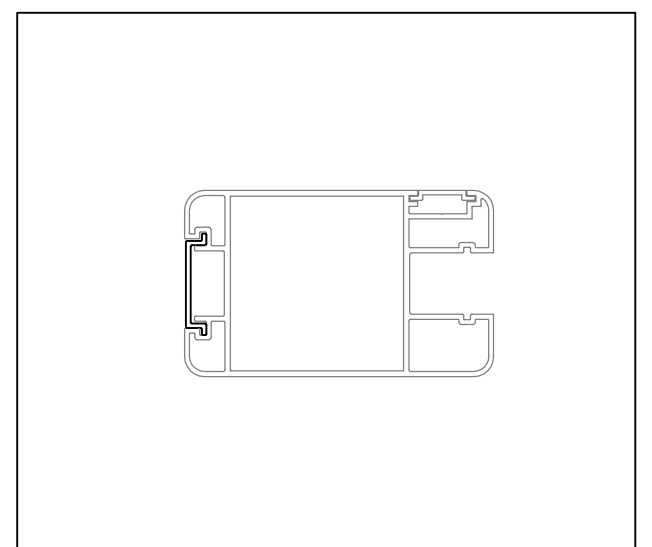
	CK-A5b	1
	AT-A5a	1
	SR-A5a	1



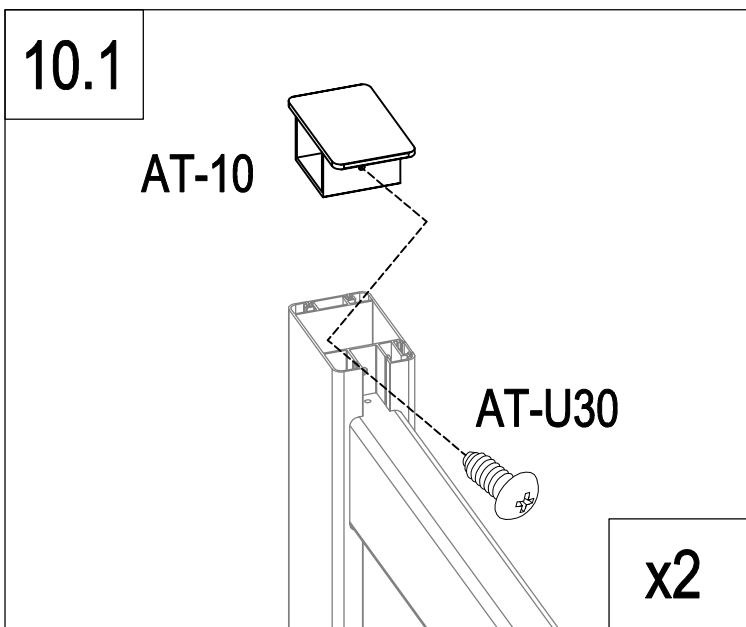
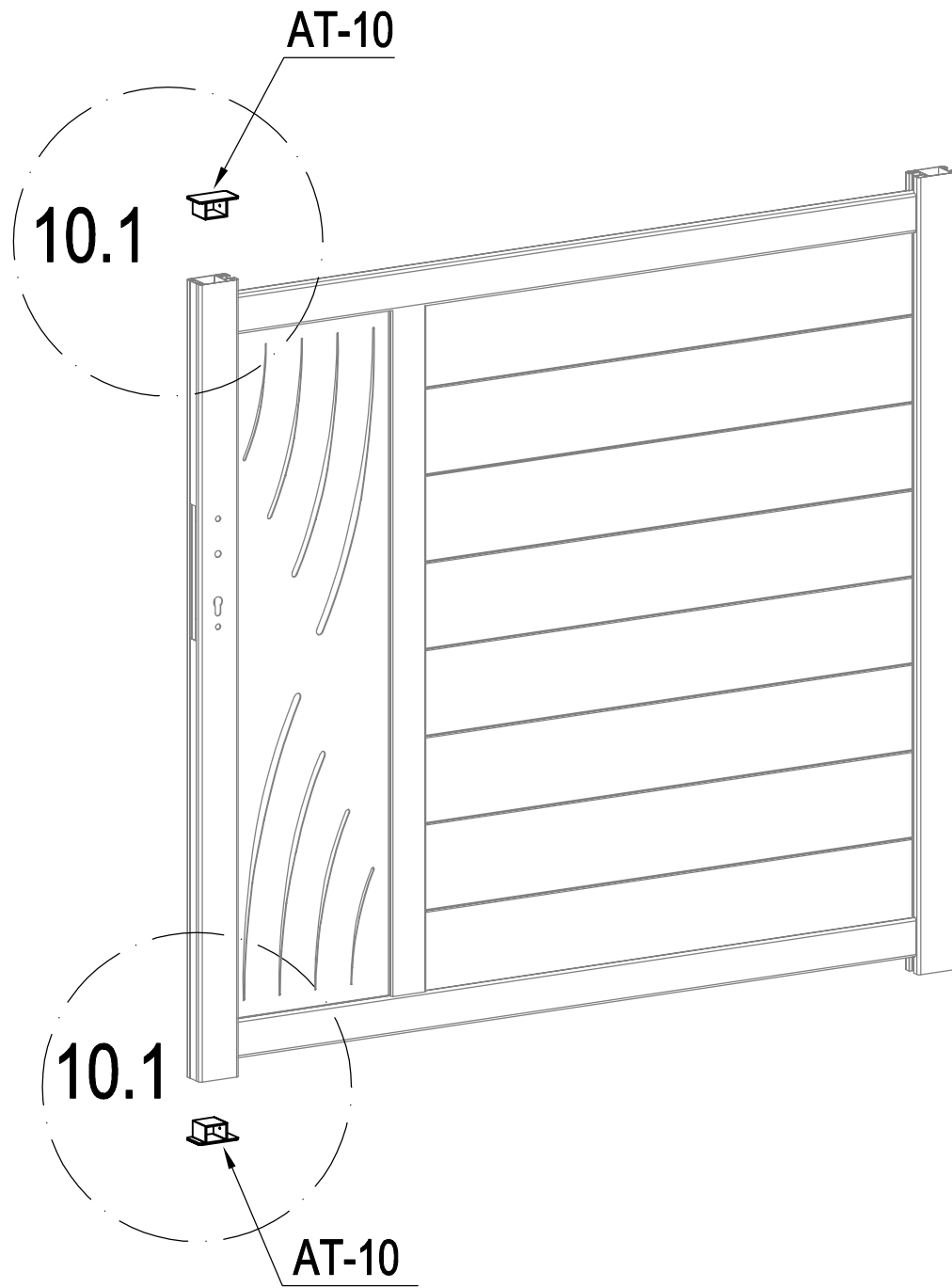

B

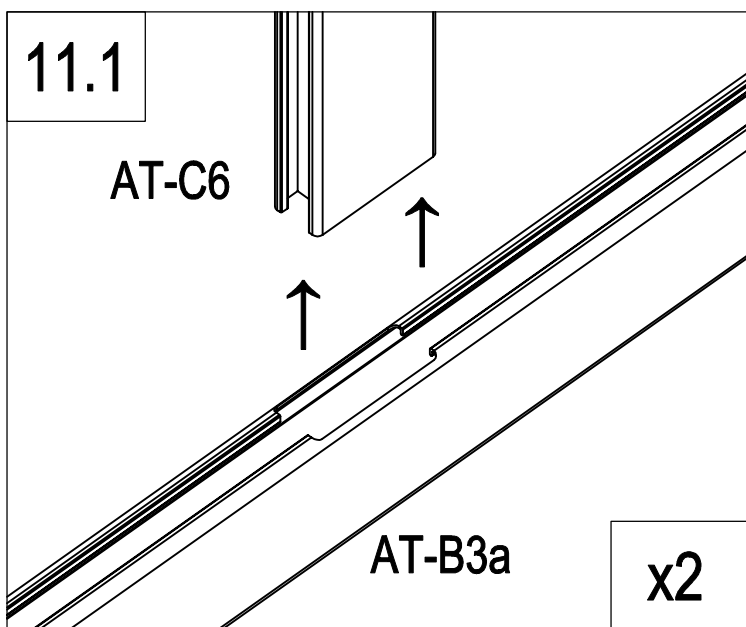
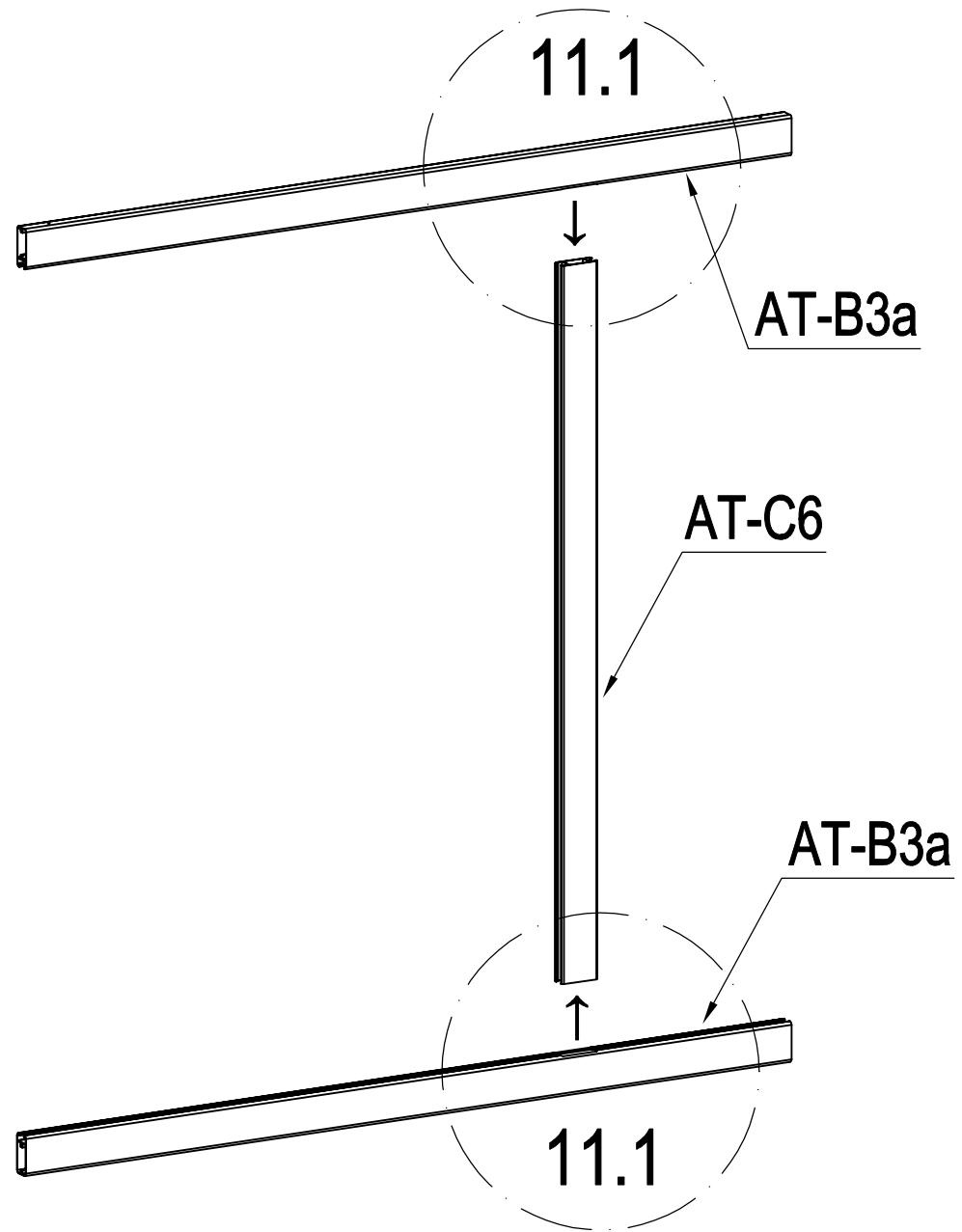

	AT-10	2
	AT-U30	2

B



	AT-C6	1
	AT-B3a	2

B

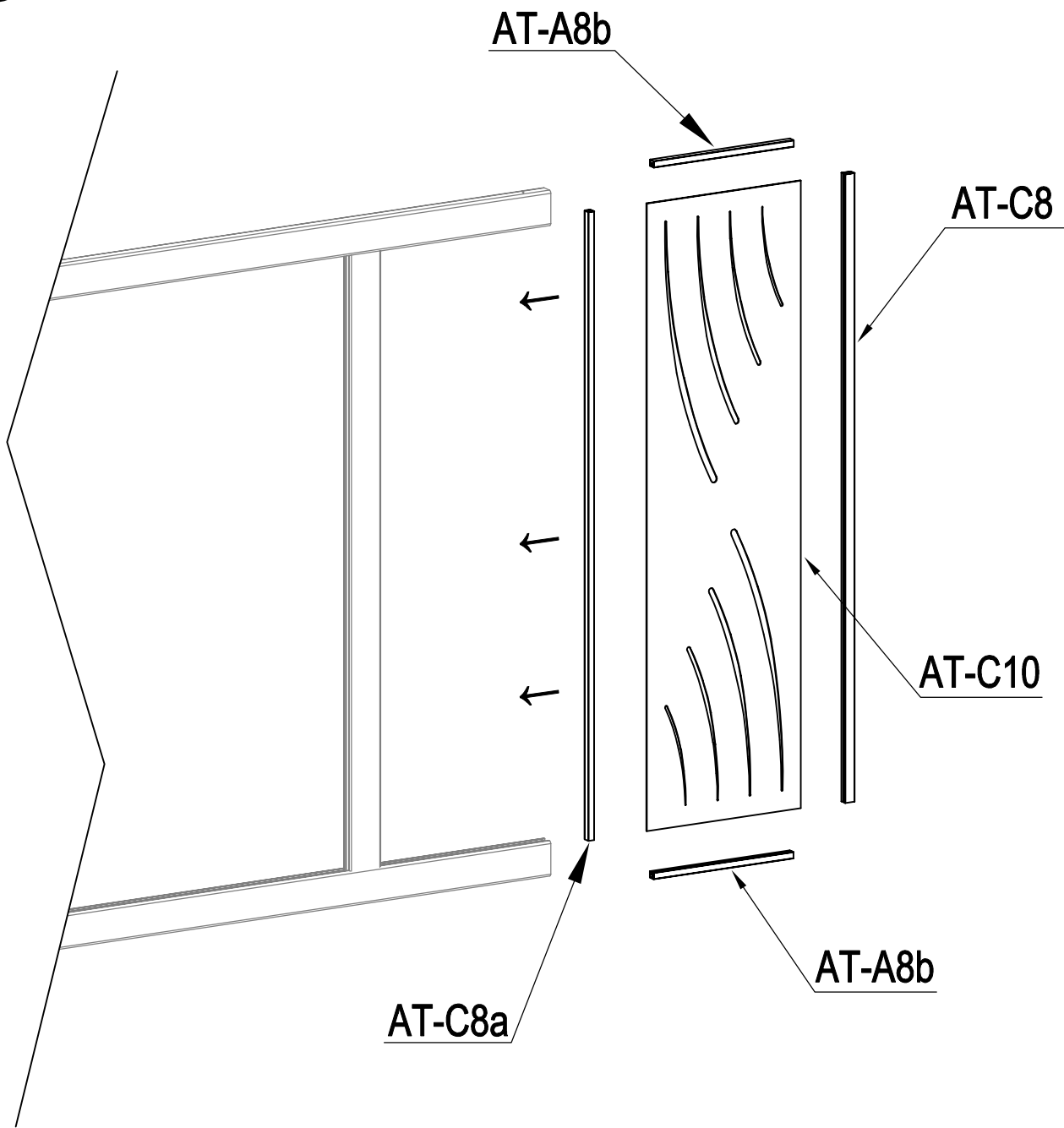

EN :you can flip and switch the direction of this plate to personalize your gate
 FR: vous pouvez retourner et changer la direction de cette plaque pour personnaliser votre portail
 DE: Sie können dieses Schild umdrehen und die Richtung wechseln, um Ihr Tor zu personalisieren.
 ES: puedes girar y cambiar la dirección de esta placa para personalizar tu puerta
 PT: pode virar e mudar a direção desta placa para personalizar o seu portão
 IT: potete capovolgere e cambiare la direzione di questa piastra per personalizzare il vostro cancello
 NL: u kunt de richting van deze plaat omdraaien en veranderen om uw poort te verpersoonlijken...
 PL: można obrócić i przełączyć kierunek tej płyty, aby spersonalizować bramę.

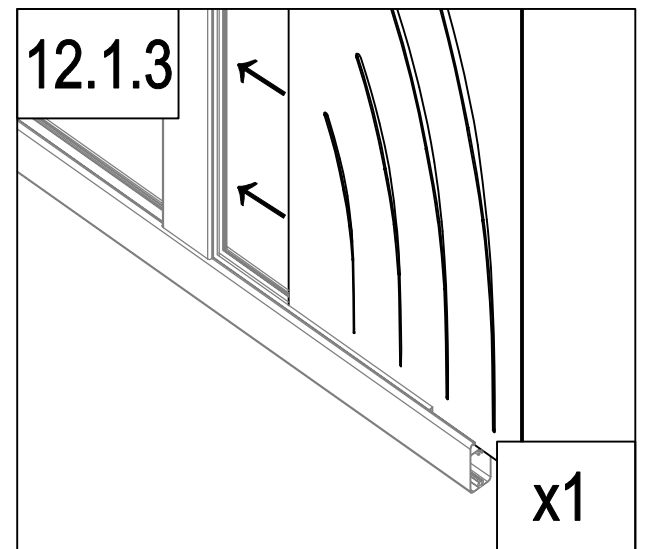
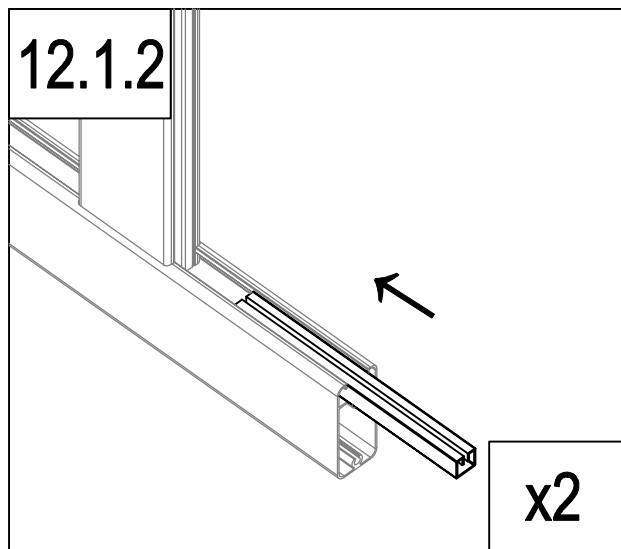
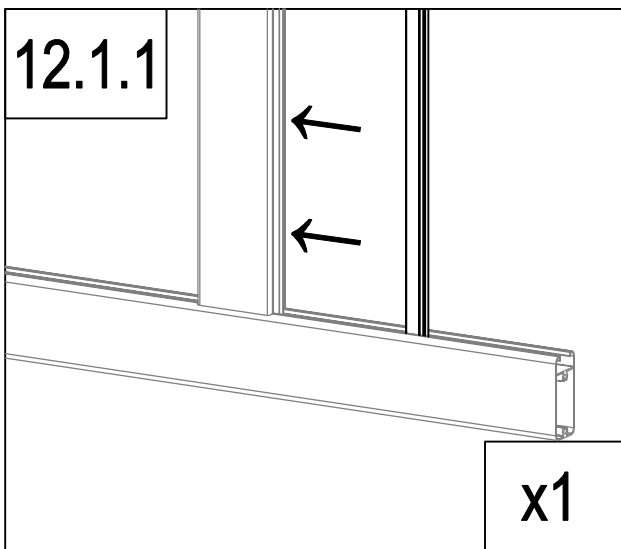

	AT-C8a	1
	AT-A8b	2
	AT-C10	1
	AT-C8	1

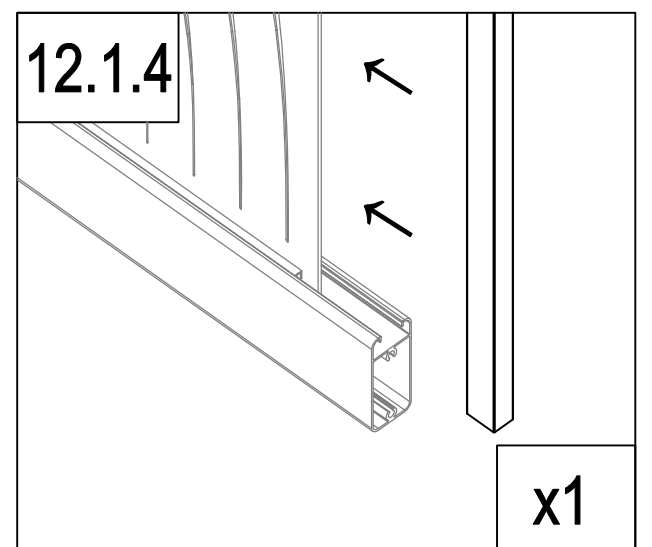

B

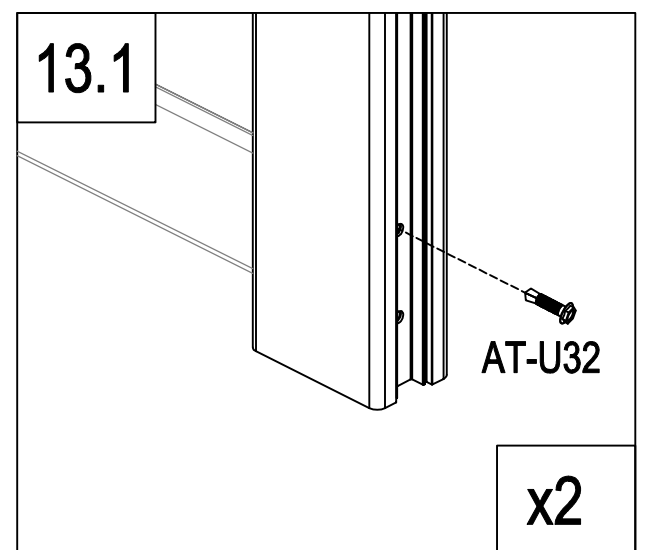
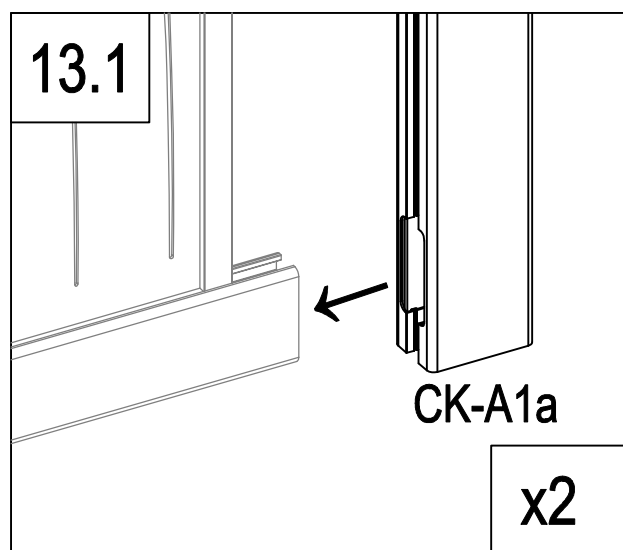
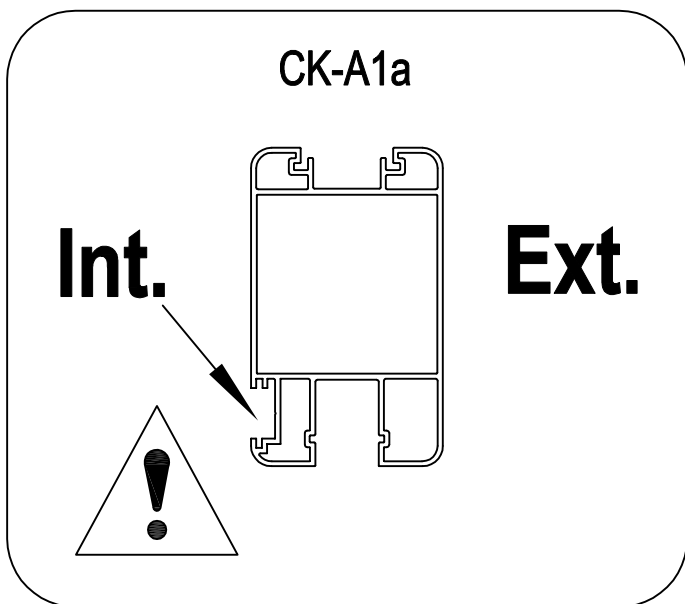
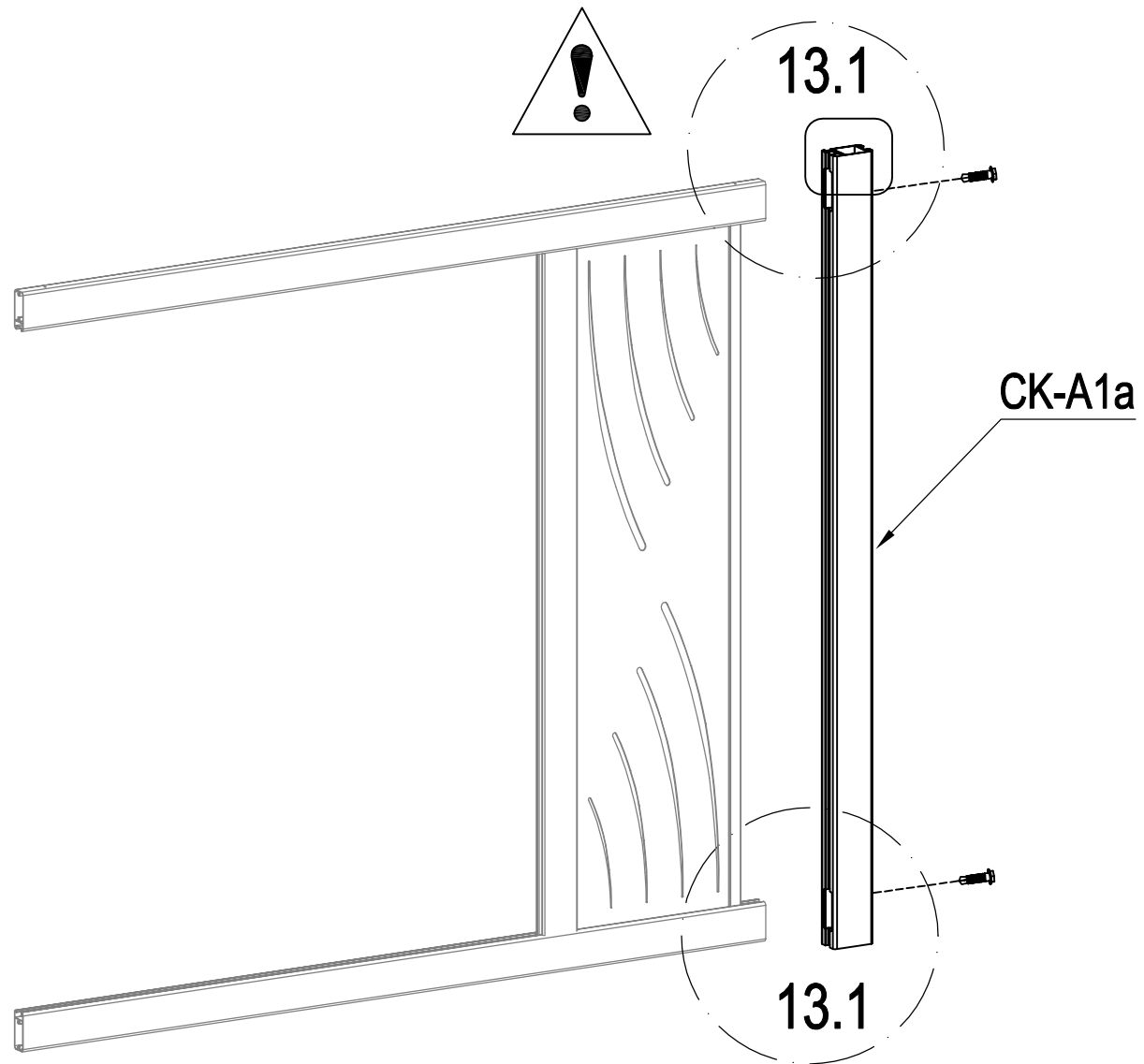

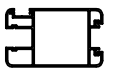
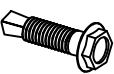
	CK-A1a	1
	AT-U32	2

B

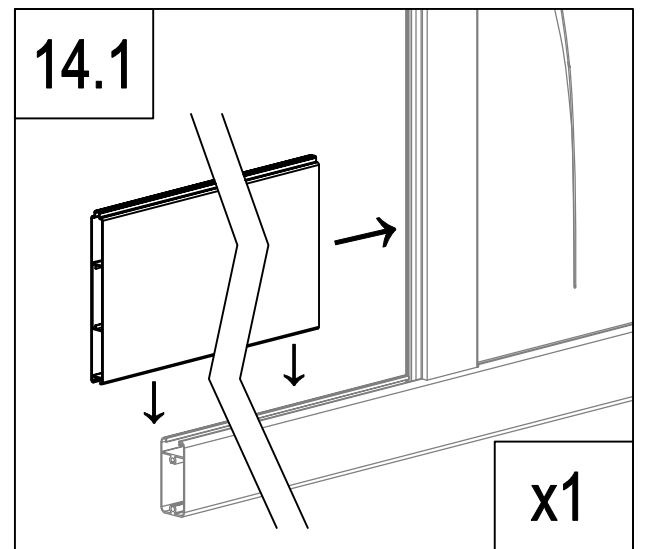
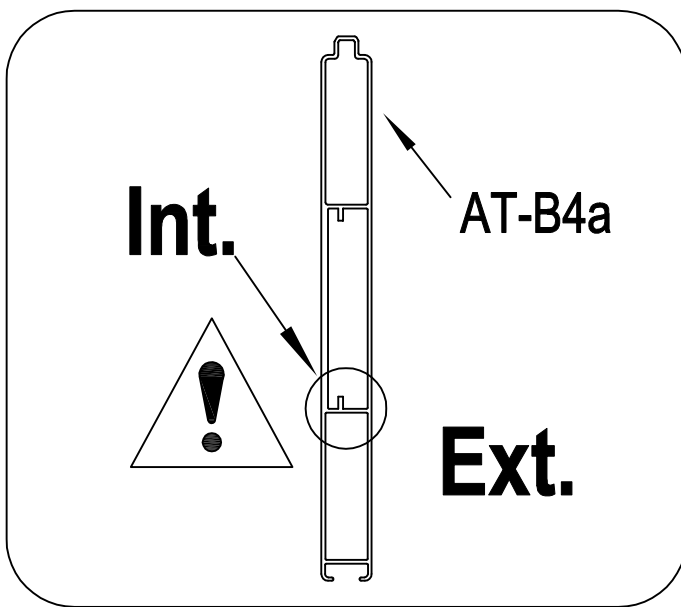
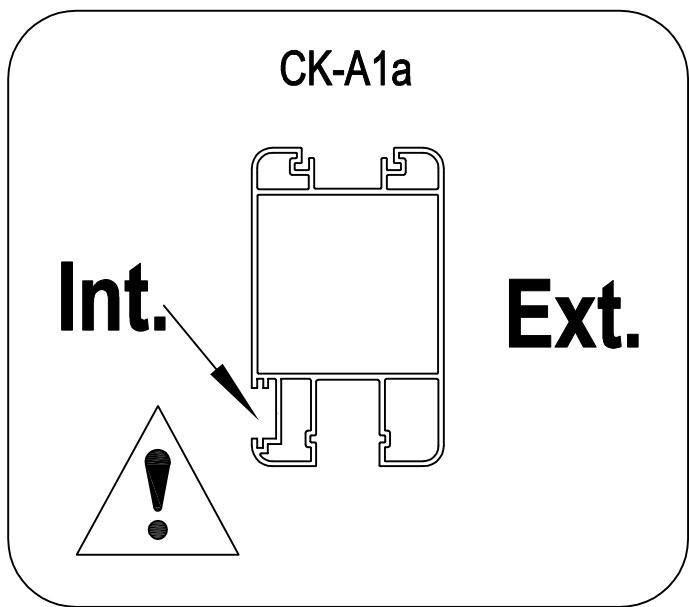
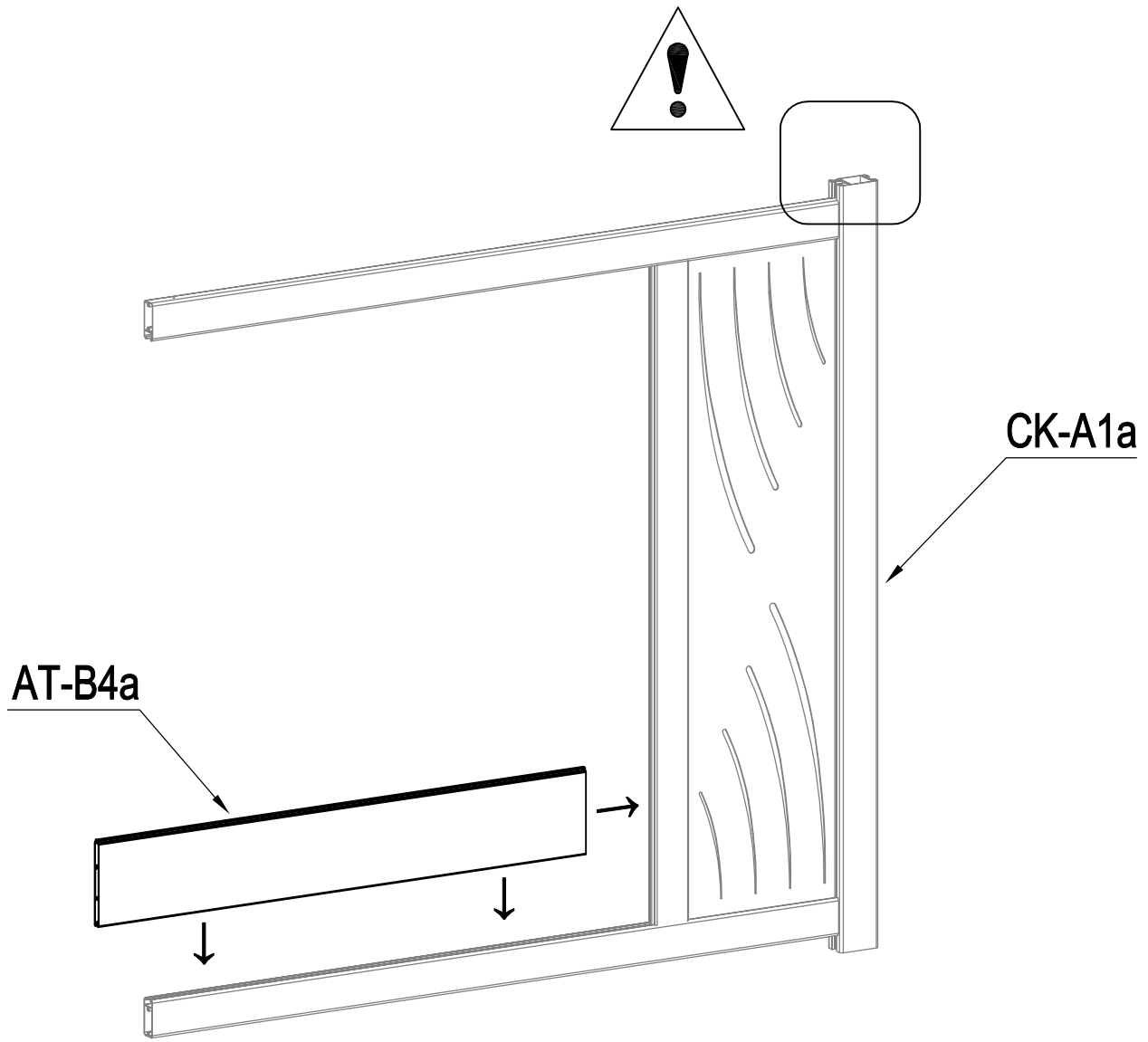

	AT-B4a	1
---	--------	---

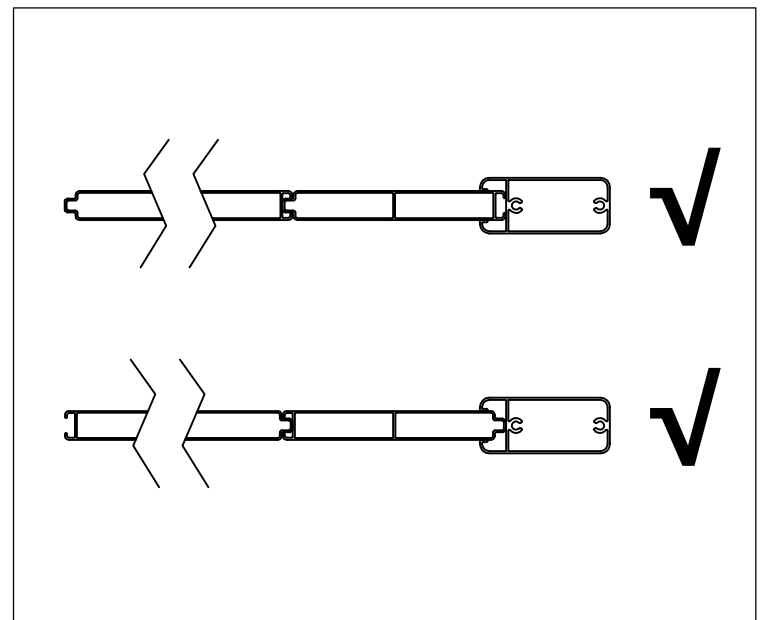
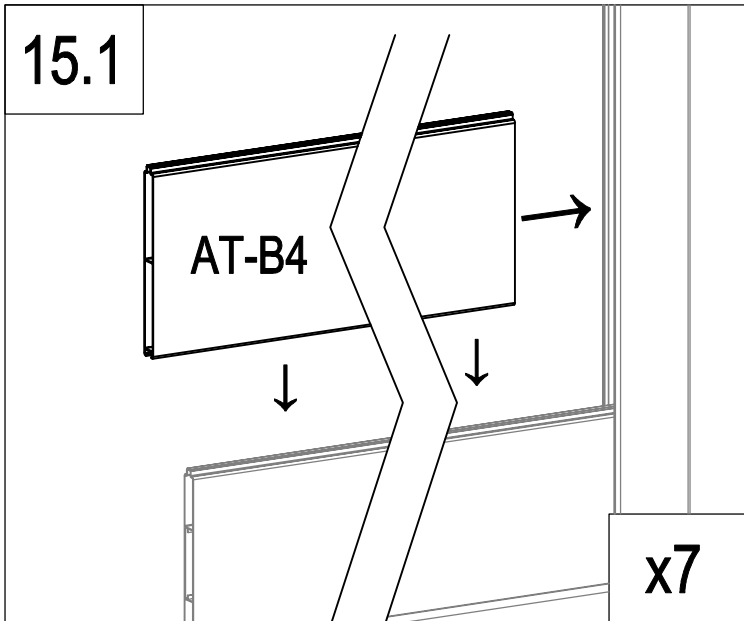
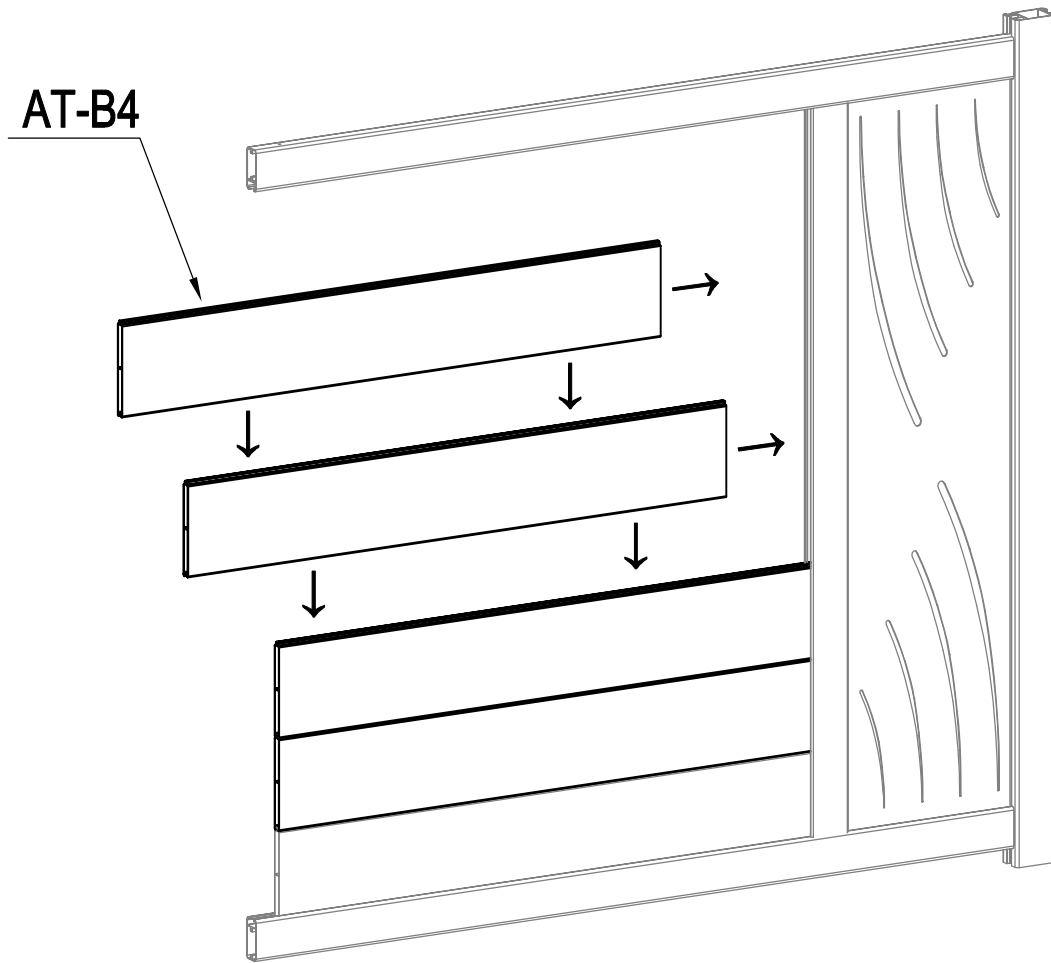

B



	AT-B4	7
---	-------	---

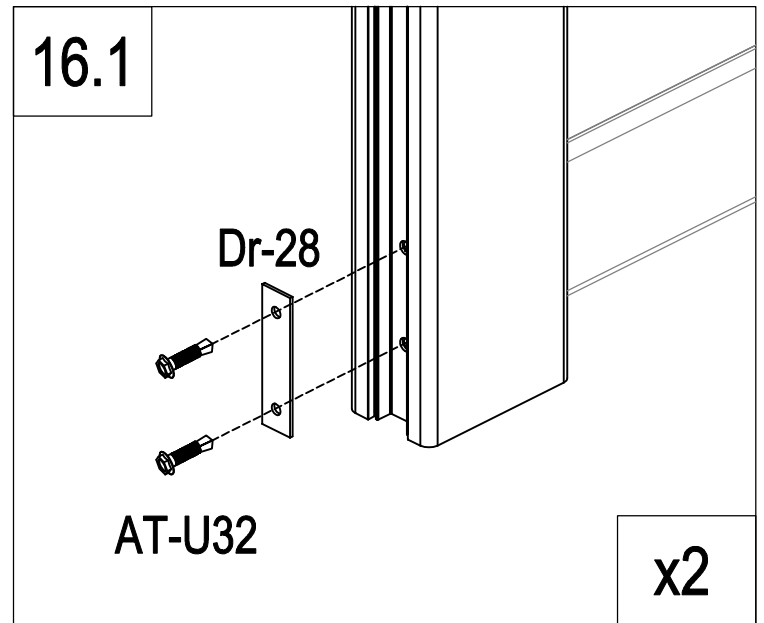
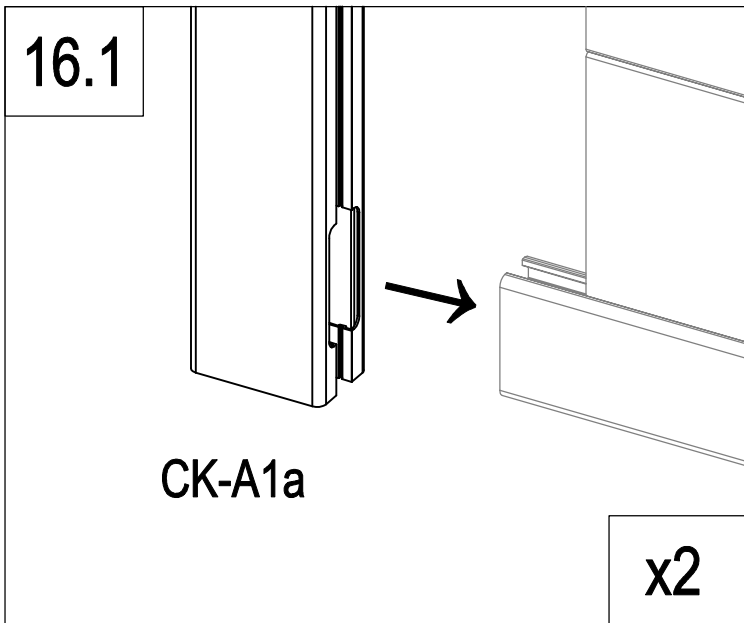
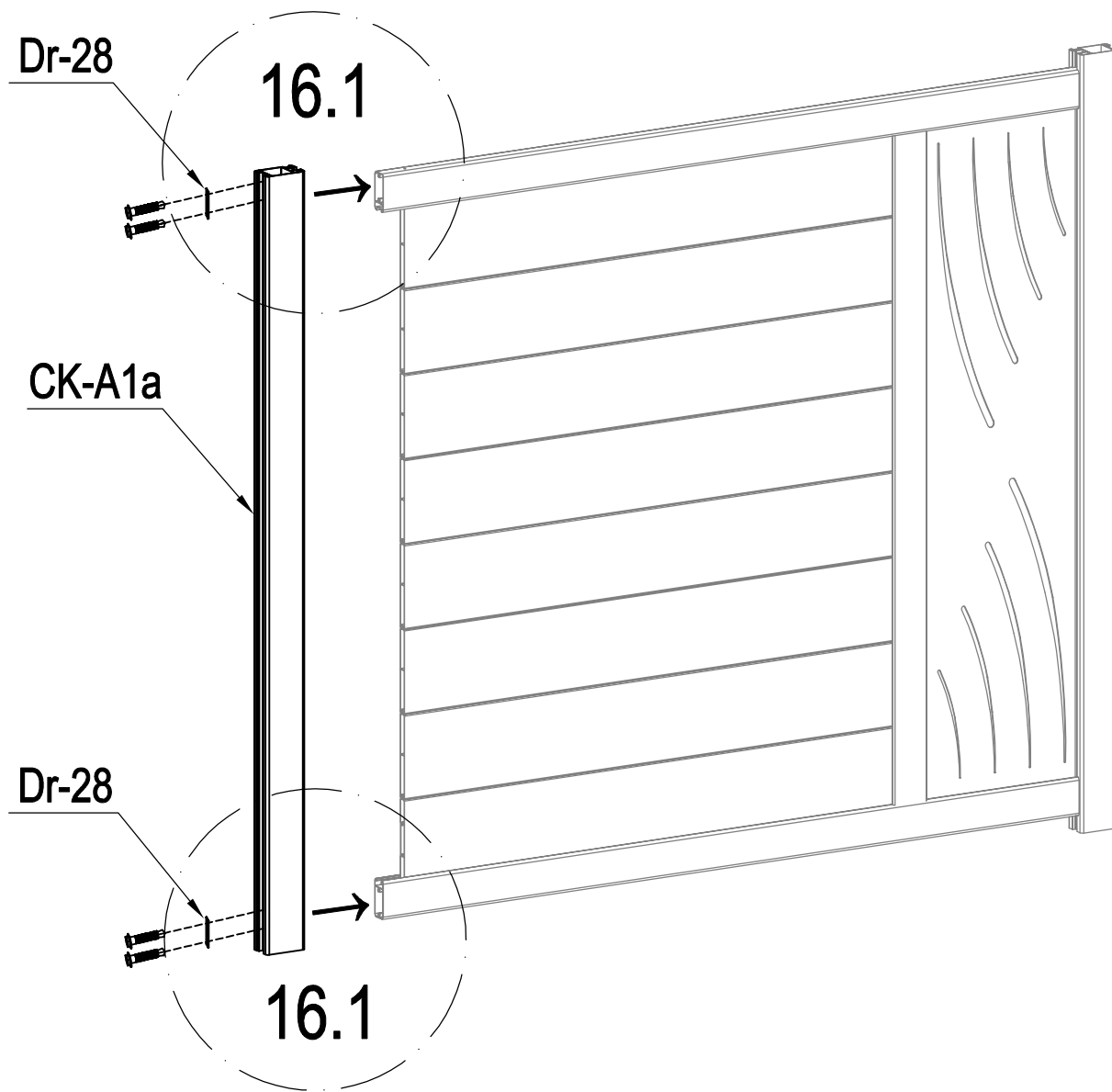

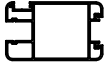
B

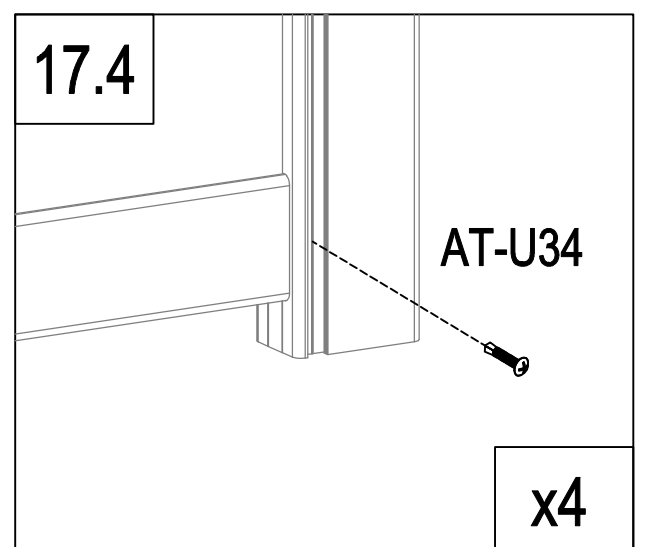
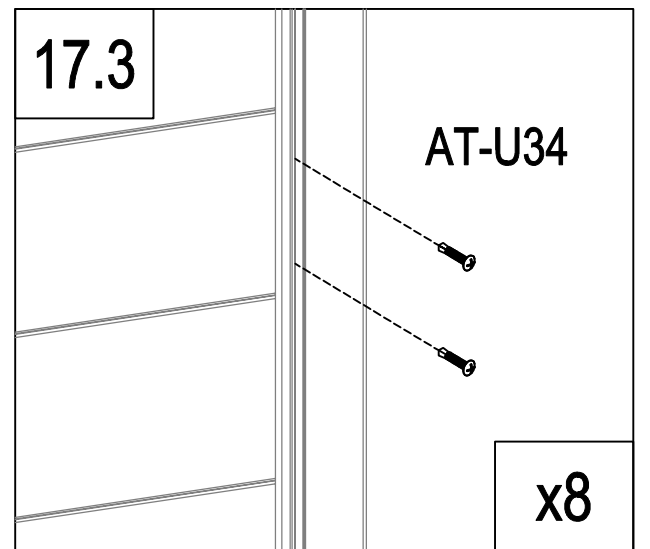
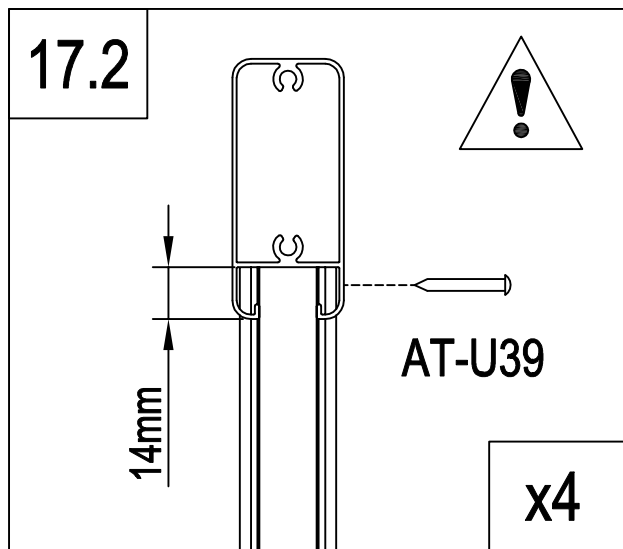
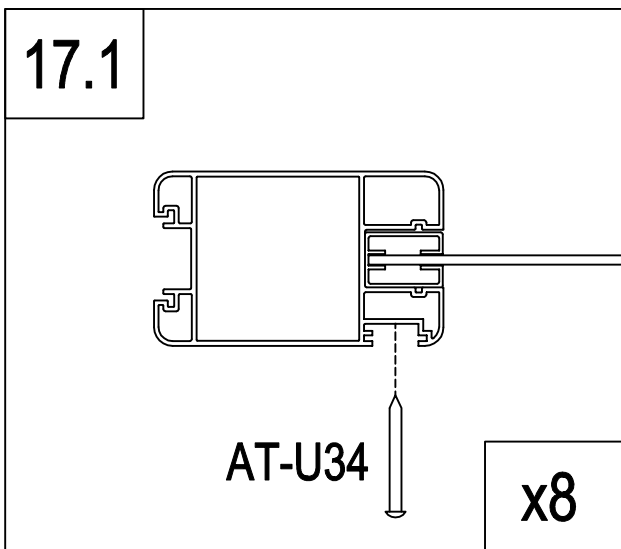
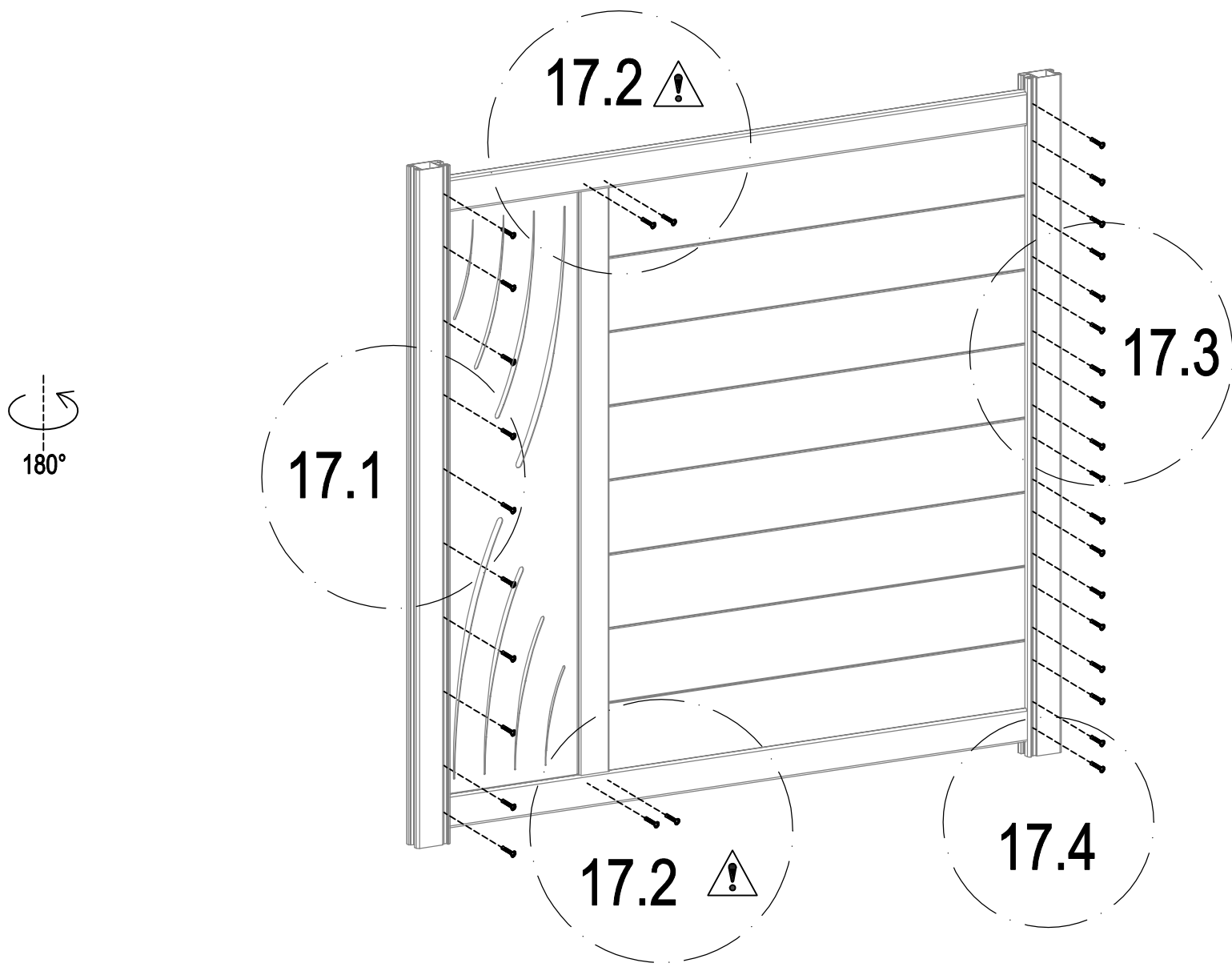

	CK-A1a	1
	Dr-28	2
	AT-U32	4

B



	AT-U34	28
	AT-U39	4

B

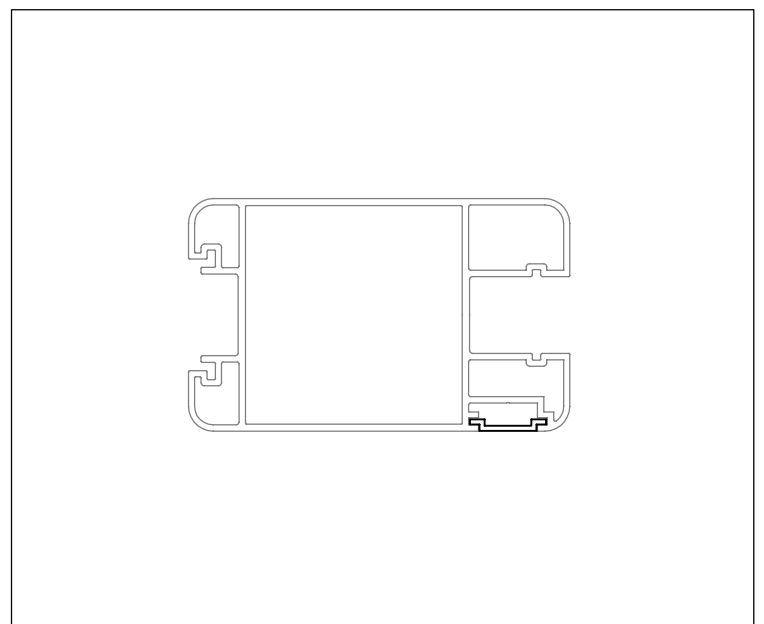
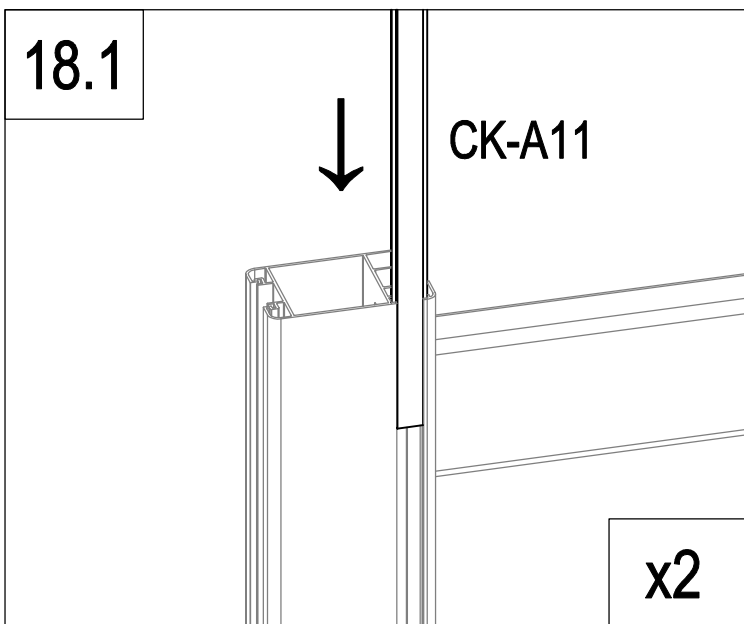
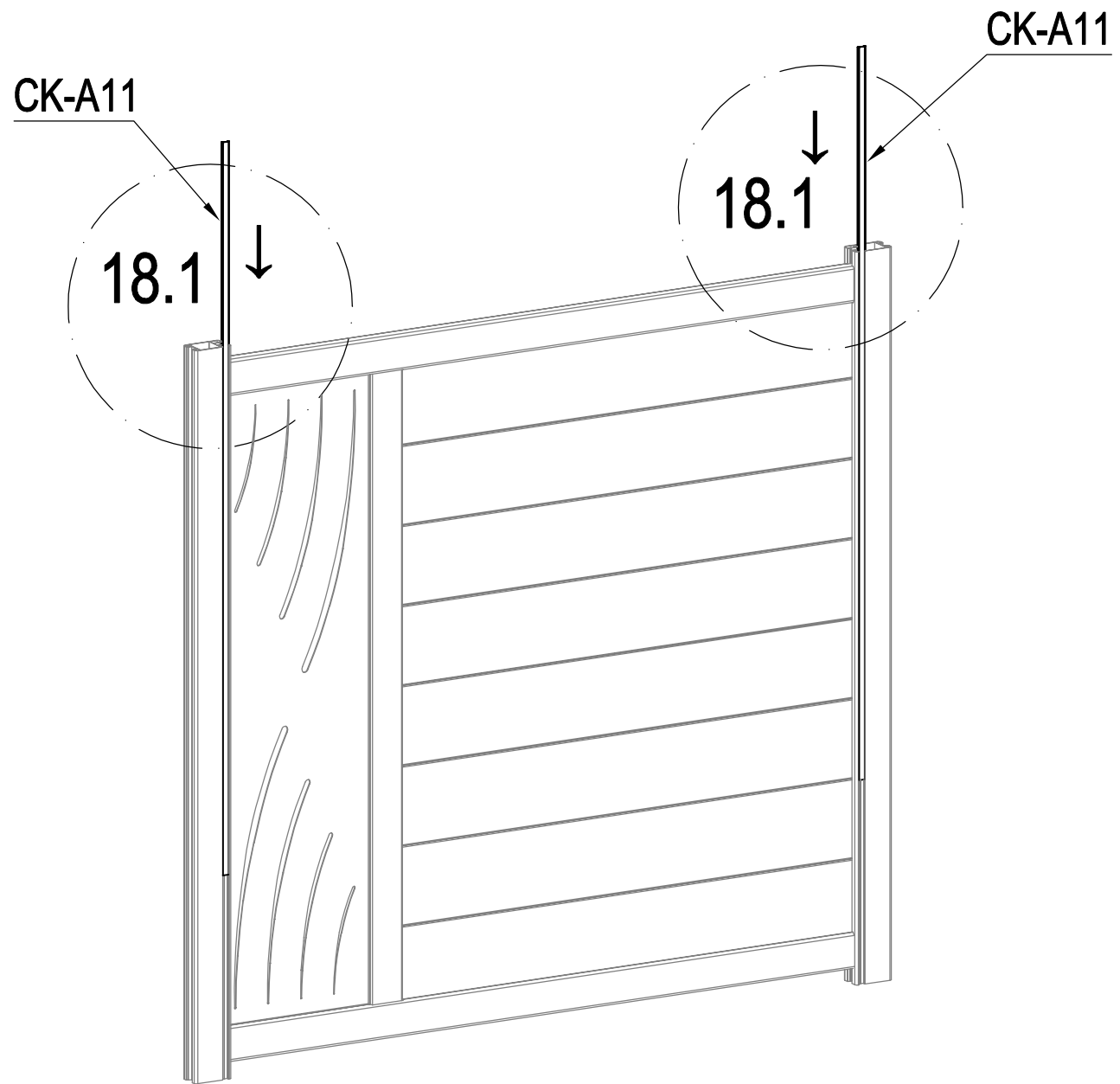



	CK-A11	2
---	--------	---

B

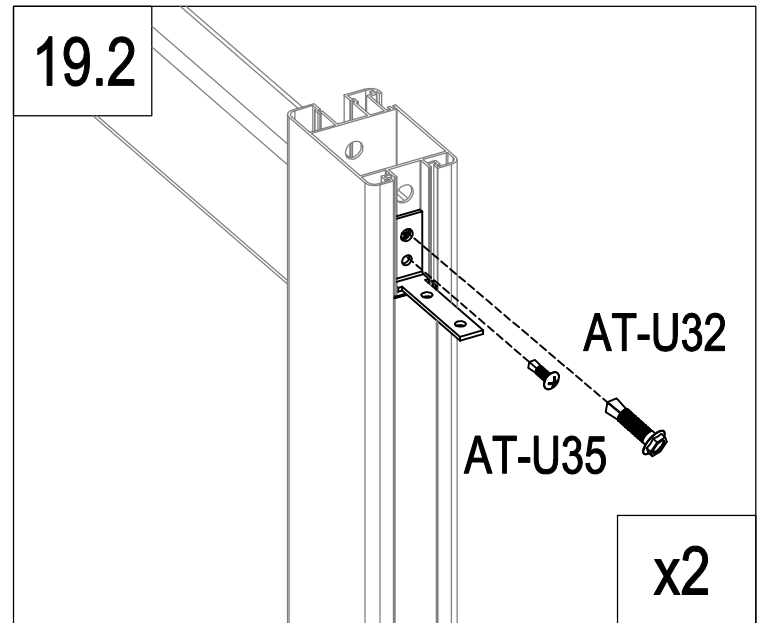
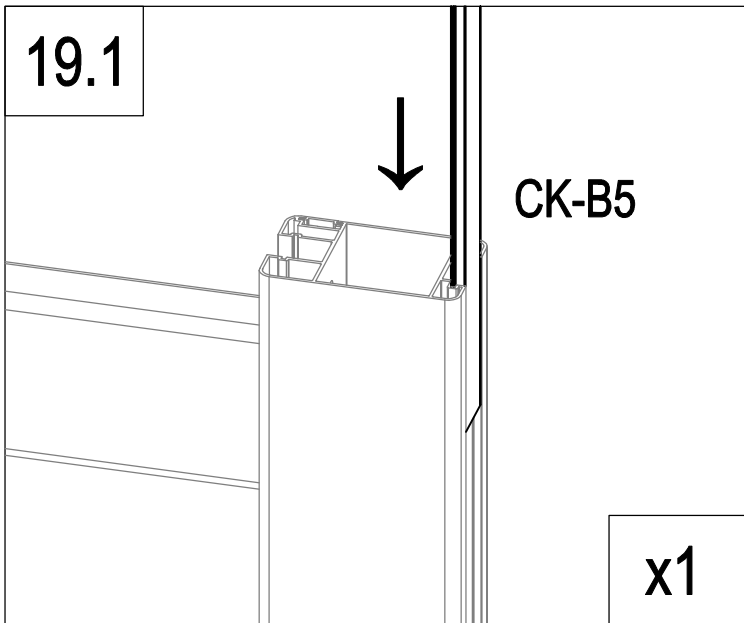
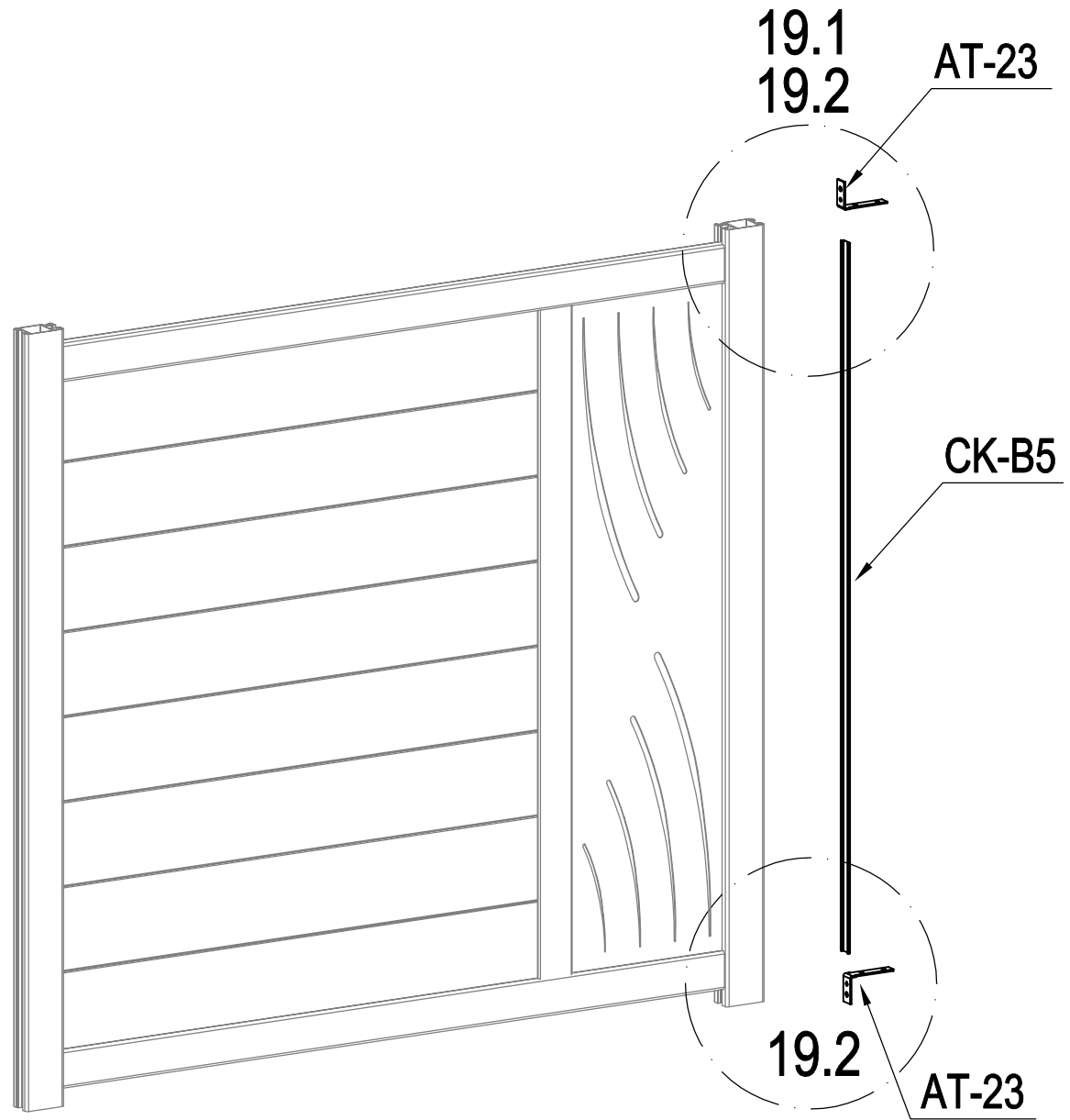
180°



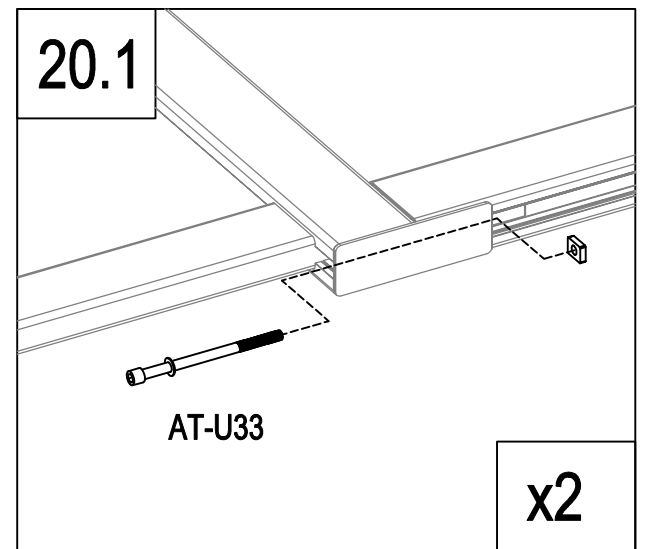
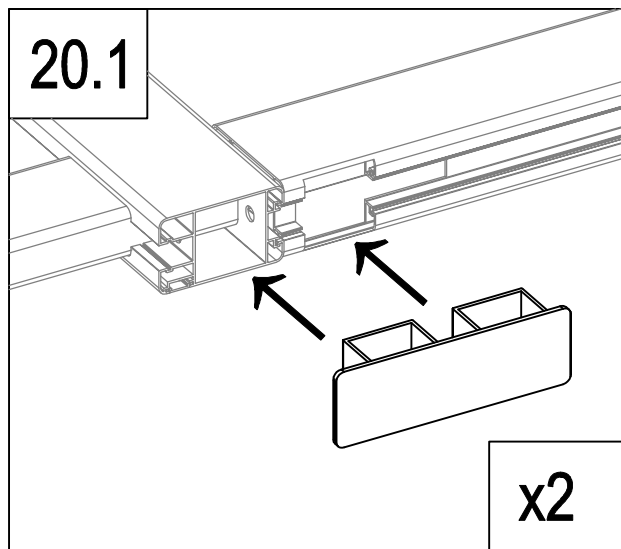
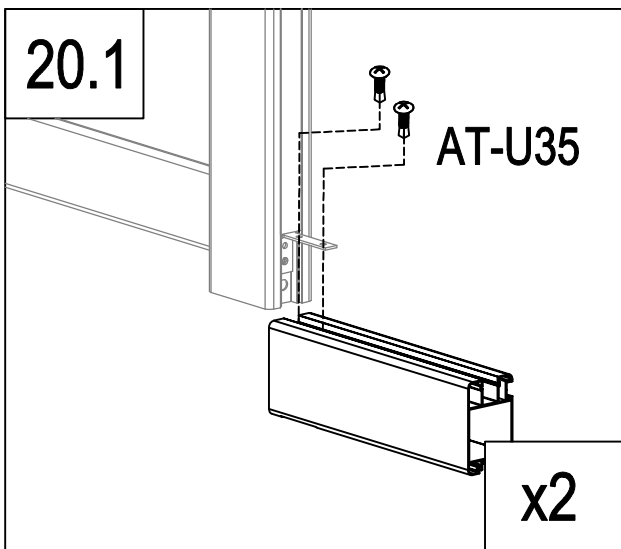
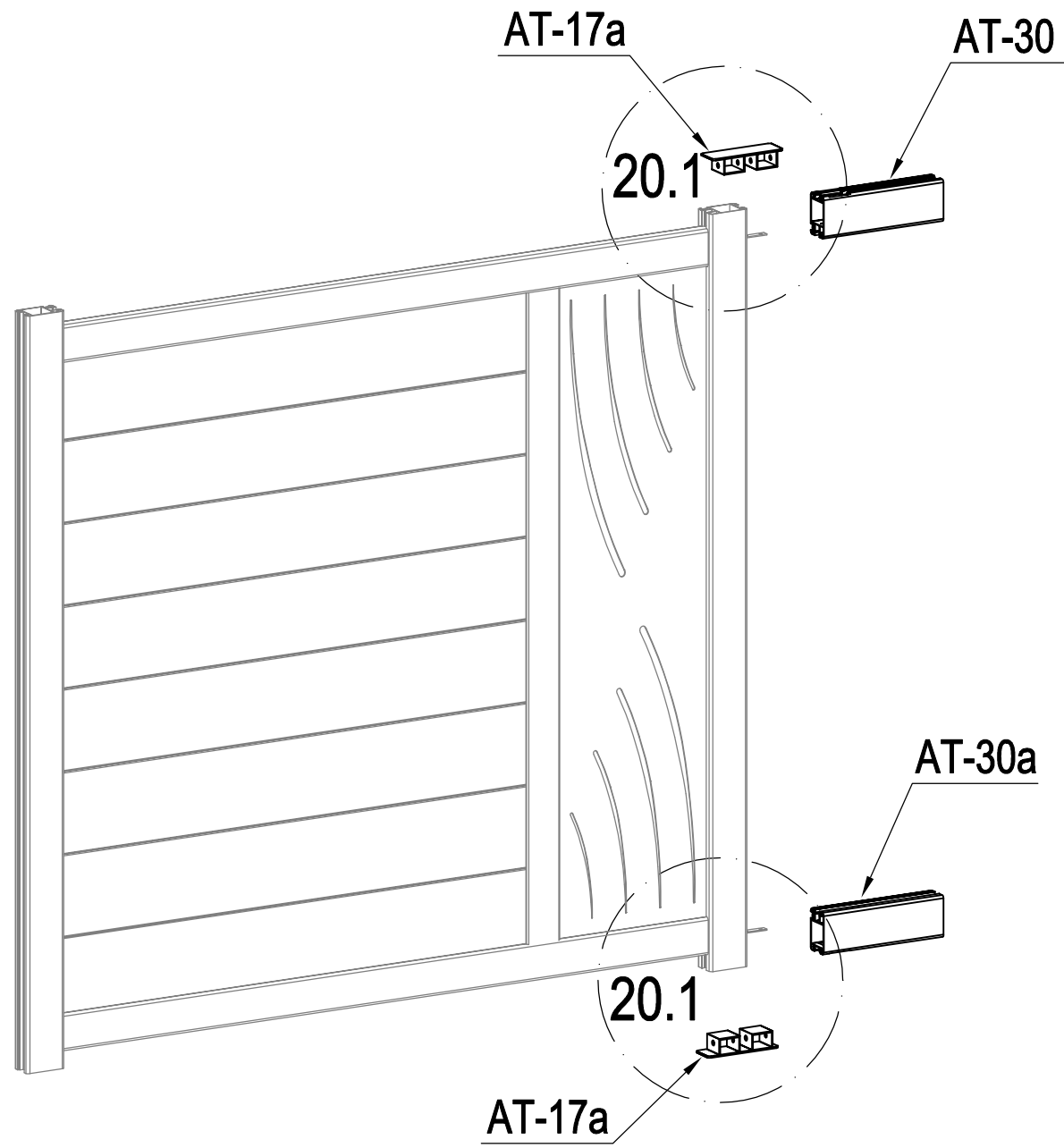

	CK-B5	1
	AT-23	2
	AT-U32	2
	AT-U35	2

B

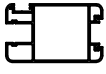
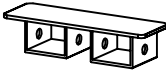



	AT-30	1
	AT-30a	1
	AT-17a	2

	AT-U33	2
	AT-U35	4

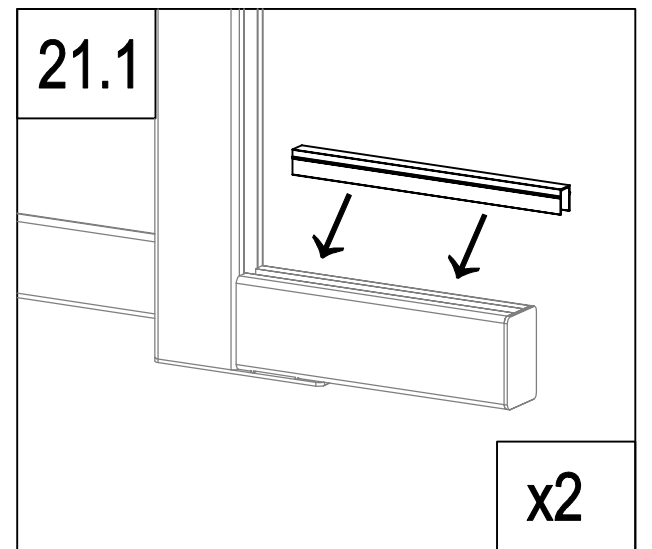
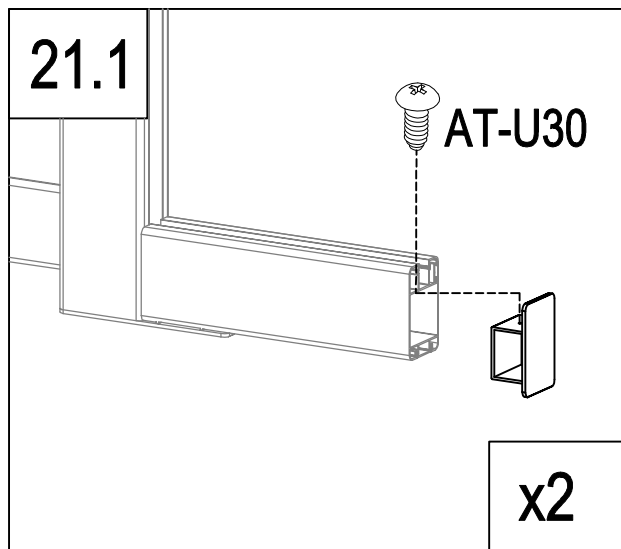
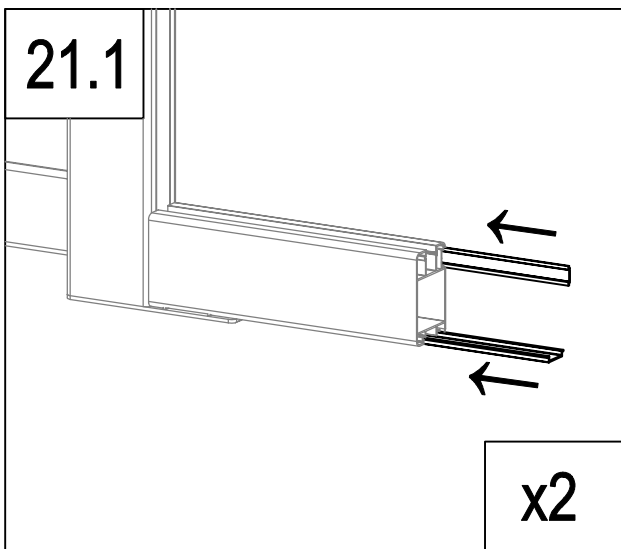
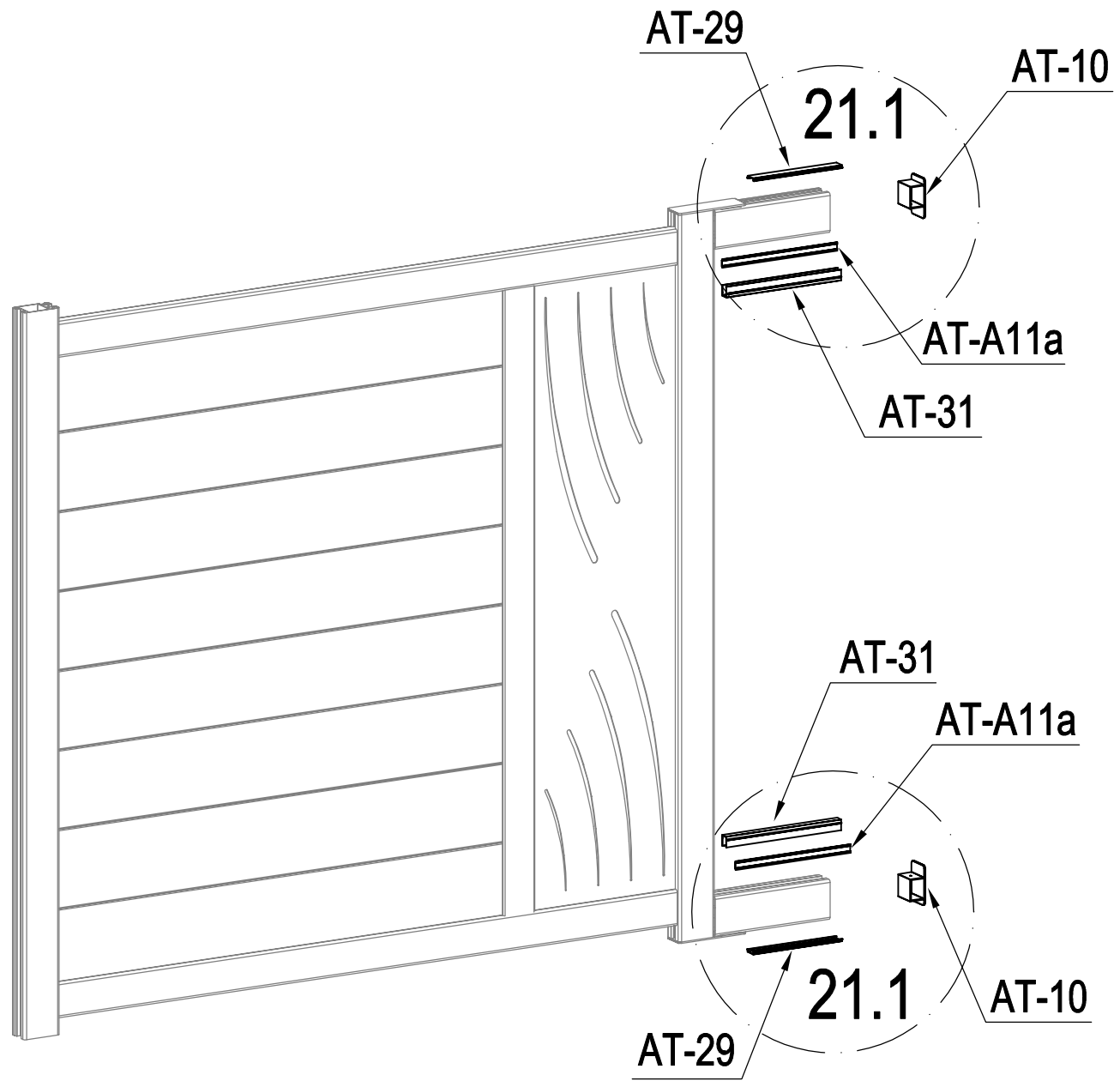
B

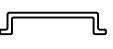
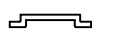
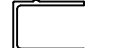



	AT-29	2
	AT-A11a	2
	AT-31	2

	AT-10	2
	AT-U30	2

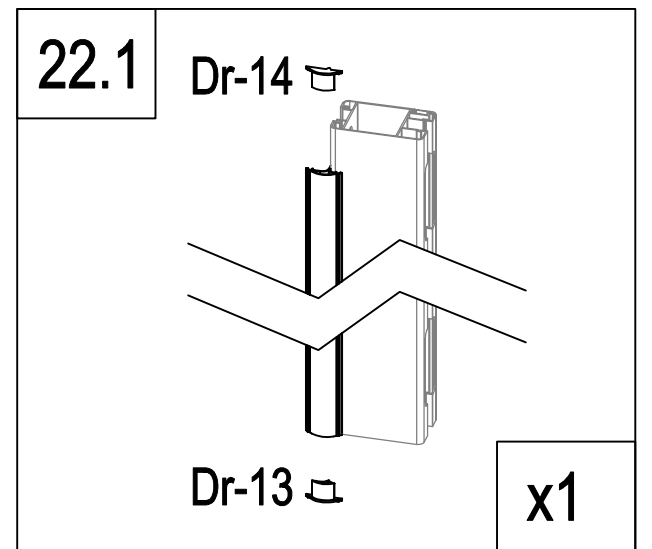
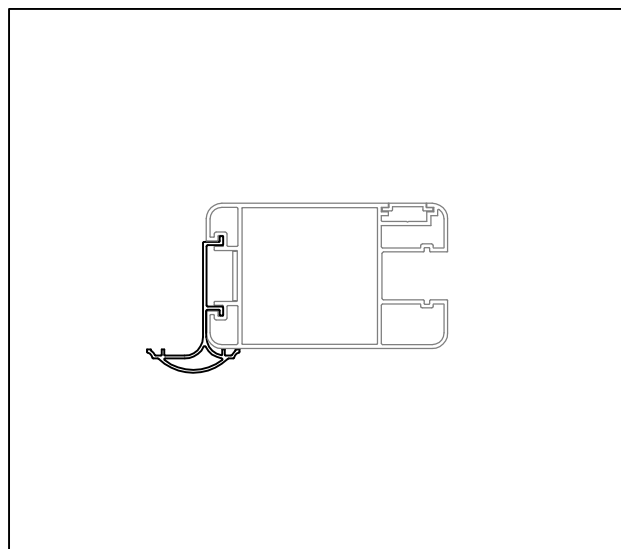
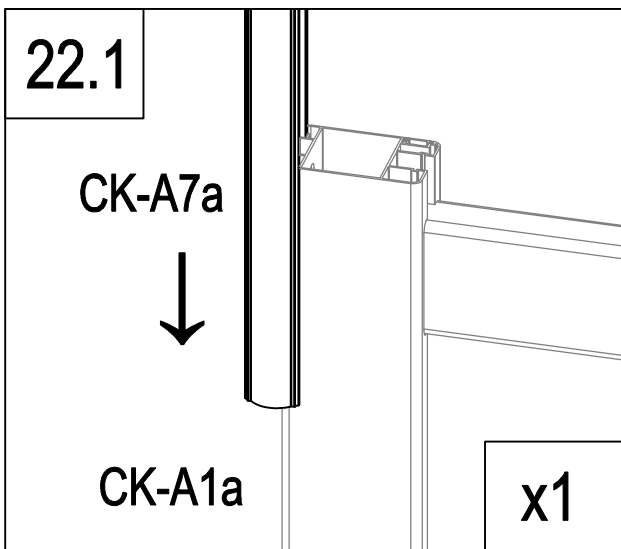
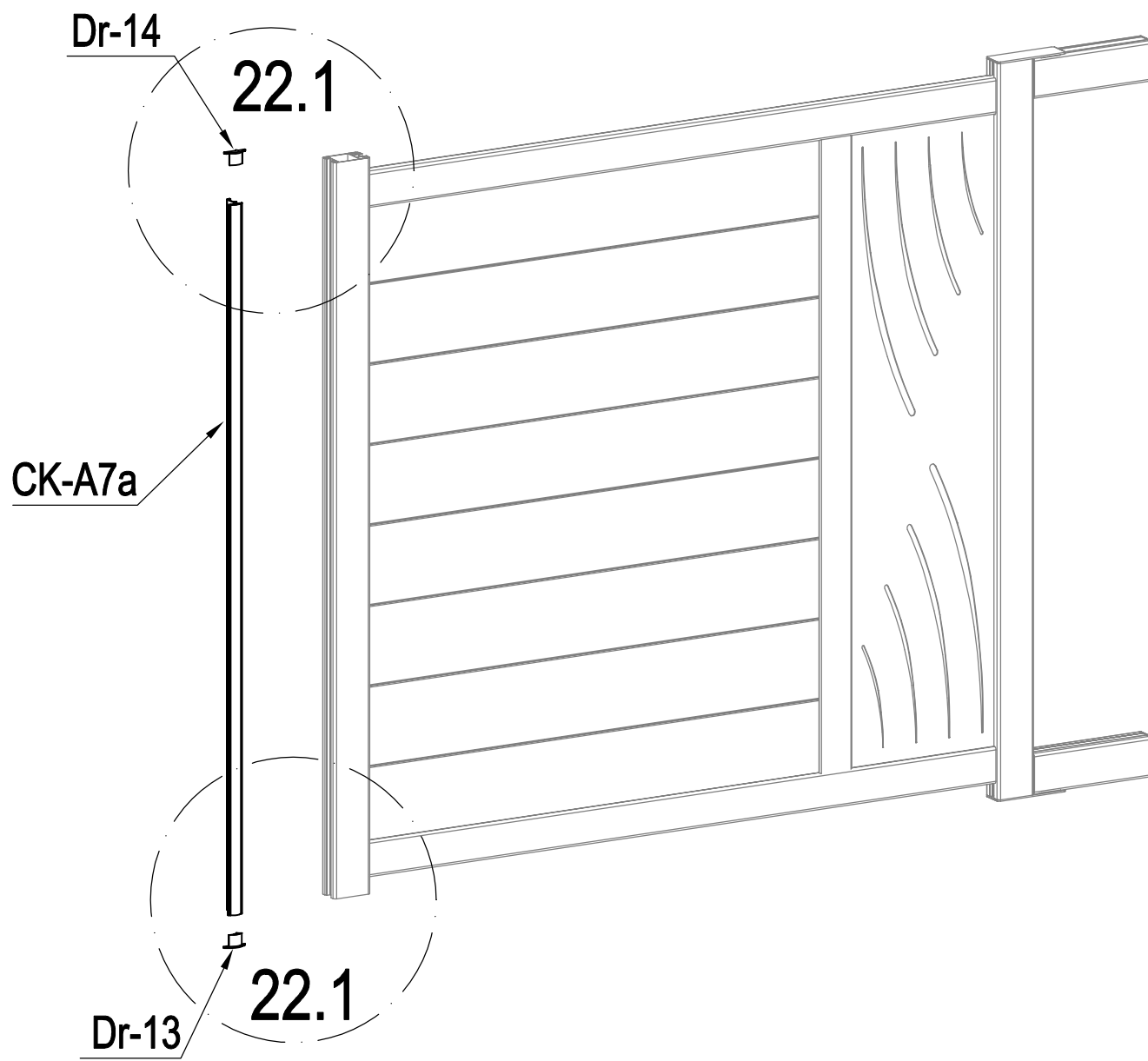

B

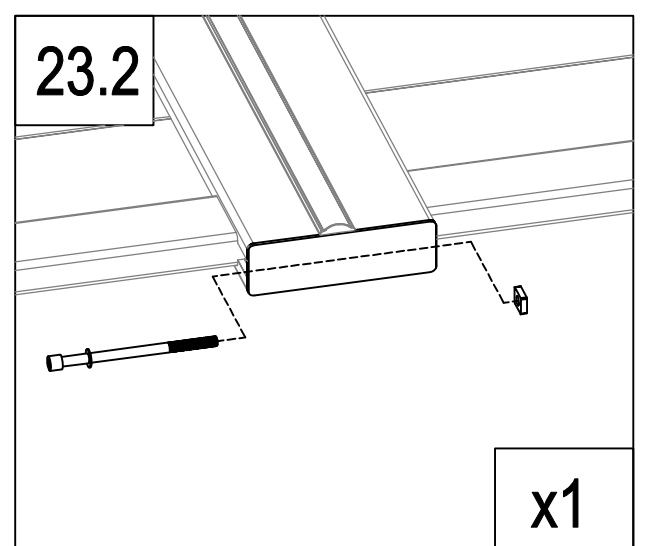
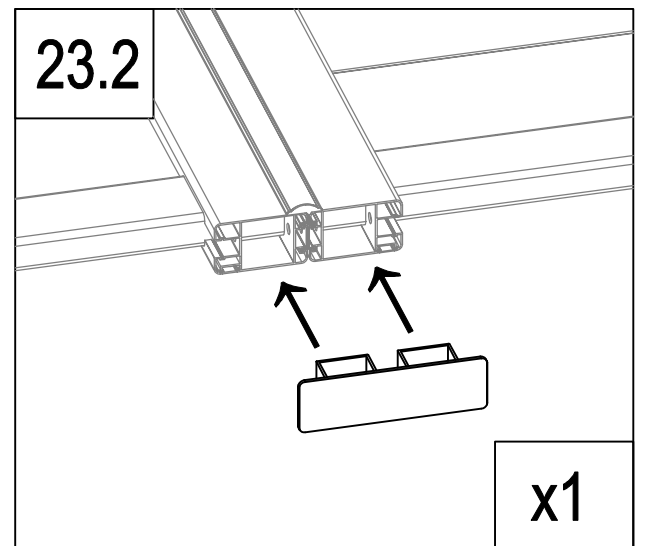
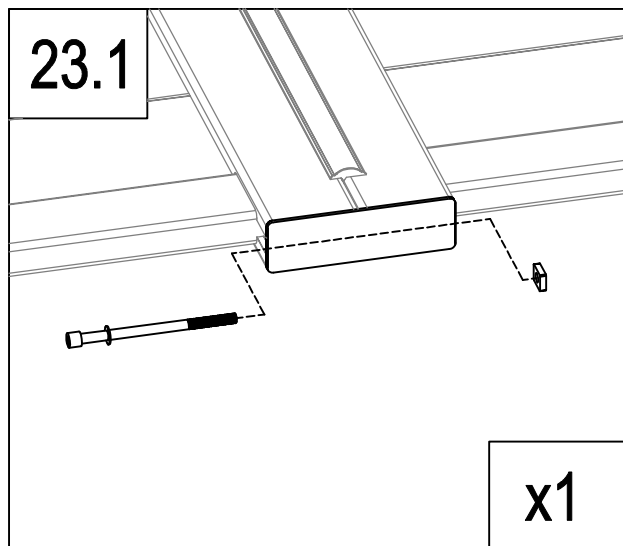
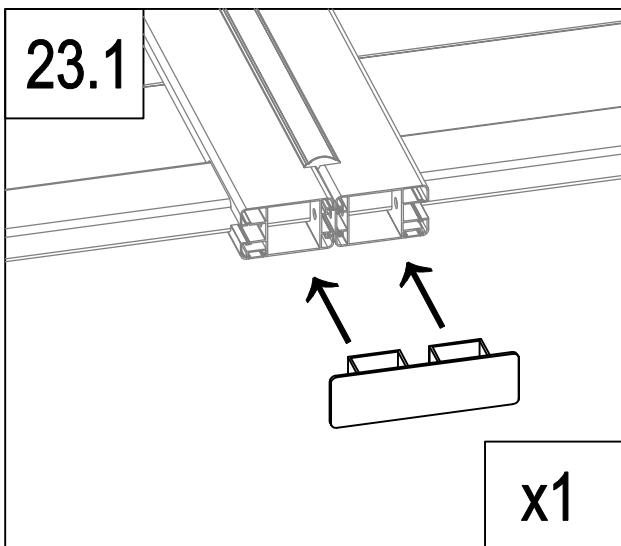
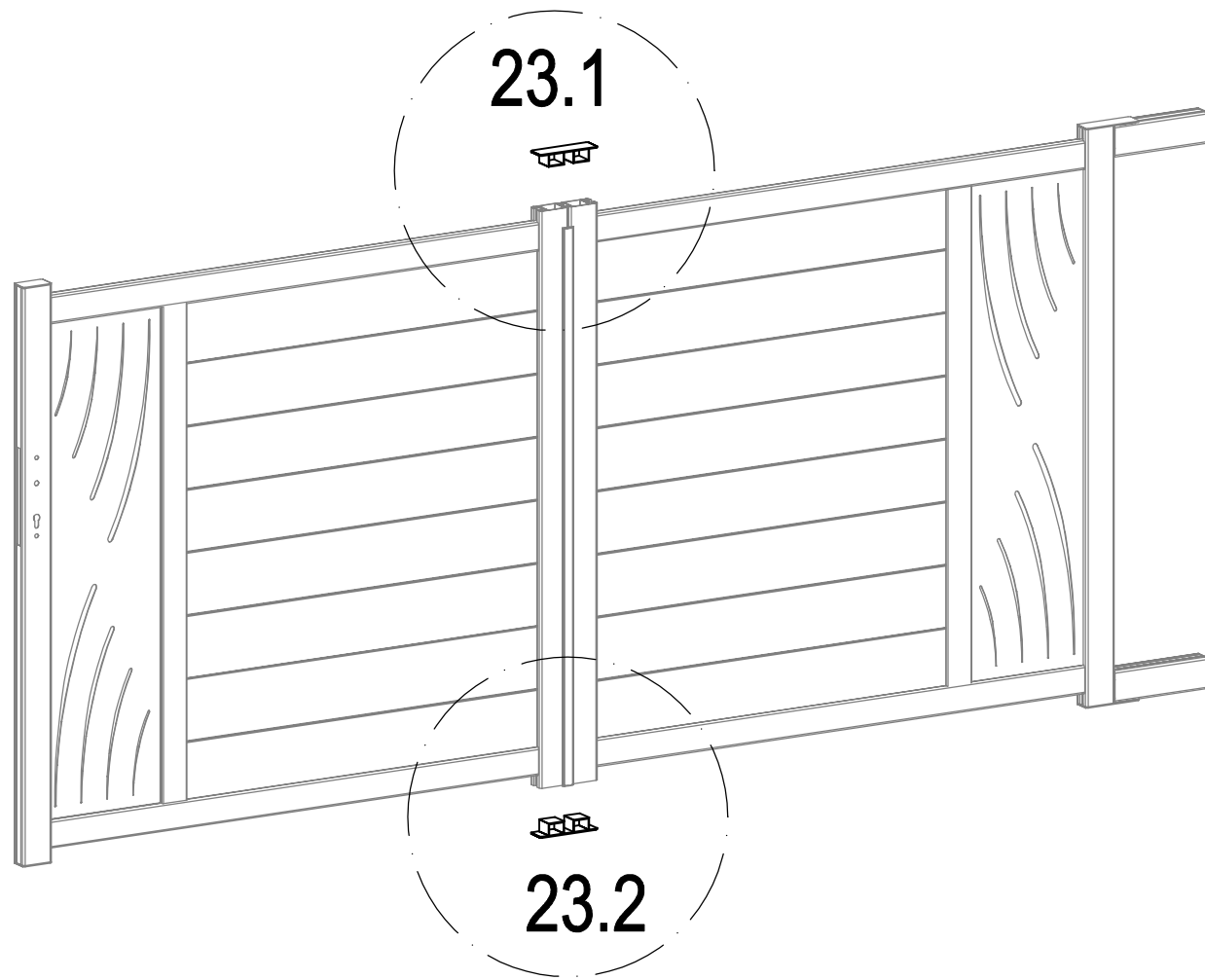

	CK-A7a	1
	Dr-13	1
	Dr-14	1

B

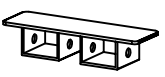

	AT-17	2
	AT-U33	2

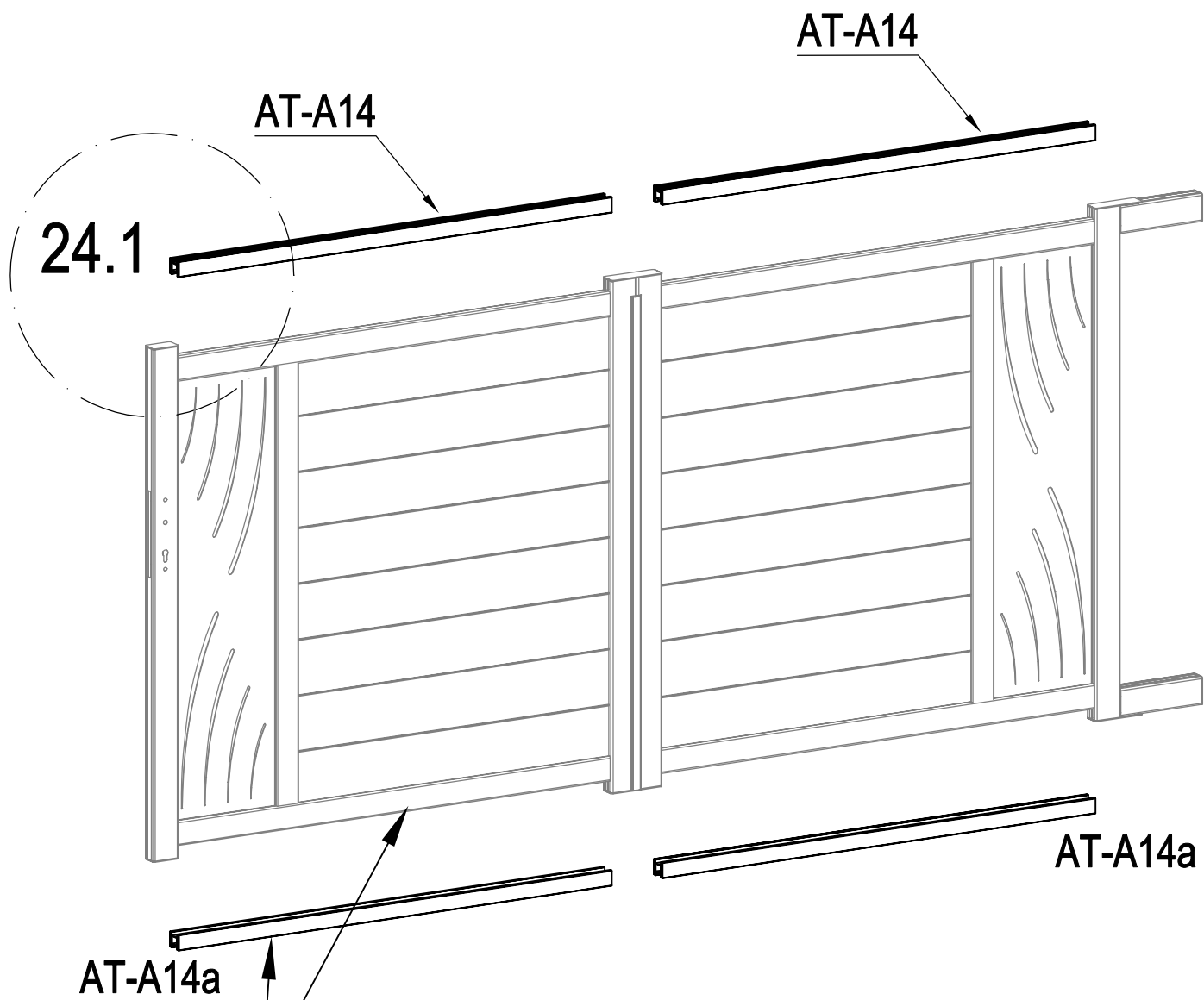
B

- EN: These parts are made for connecting your gate's automation
 FR: Ces pièces sont faites pour relier l'automatisation de votre portail
 DE: Diese Teile sind für den Anschluss der Automatisierung Ihres Tores vorgesehen
 ES: Estas piezas están hechas para conectar la automatización de su puerta
 PT: Estas peças são feitas para ligar a automatização do seu portão
 IT: Queste parti sono realizzate per collegare l'automazione del vostro cancello
 NL: Deze onderdelen zijn gemaakt voor het aansluiten van de automatisering van uw poort.
 PL: Te części są wykonane do podłączenia automatyki bramy.

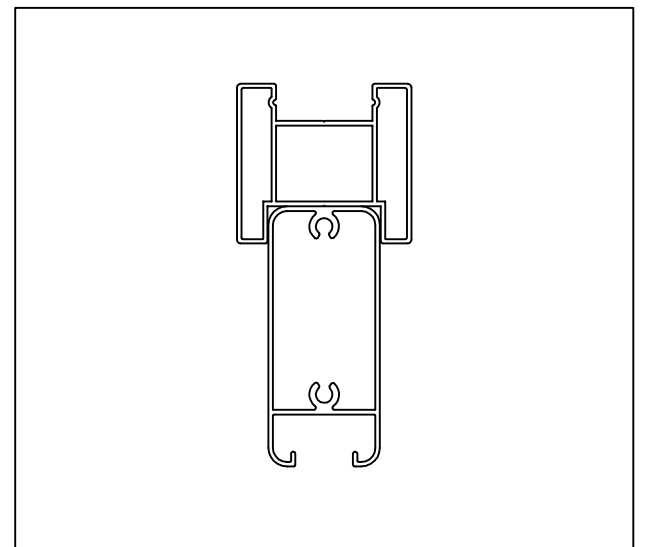
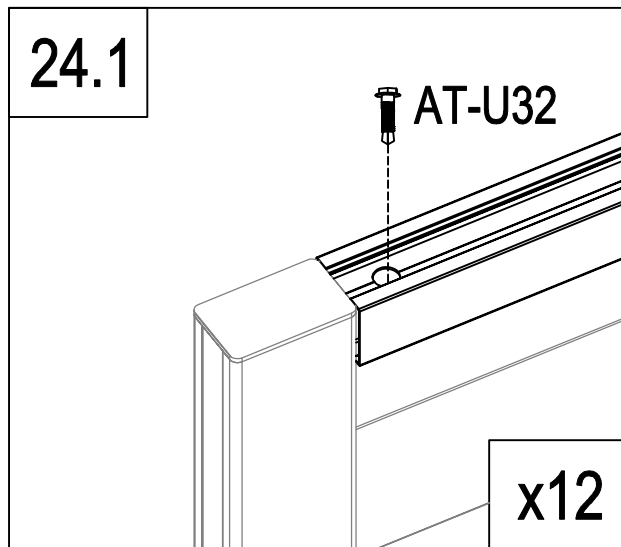
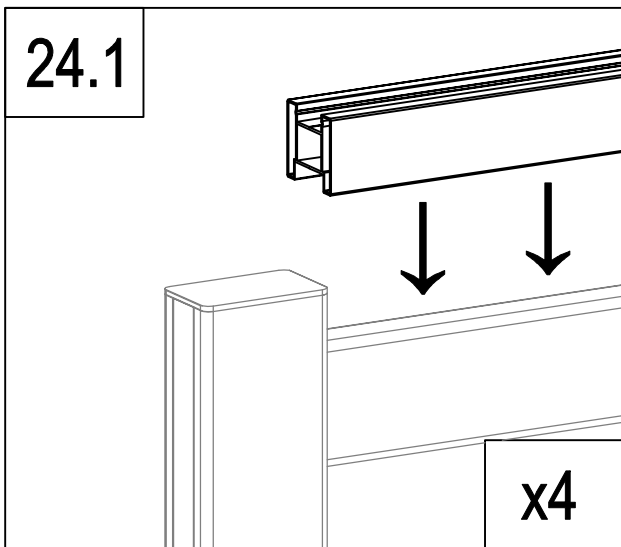

	AT-A14	2
	AT-A14a	2
	AT-U32	12

B

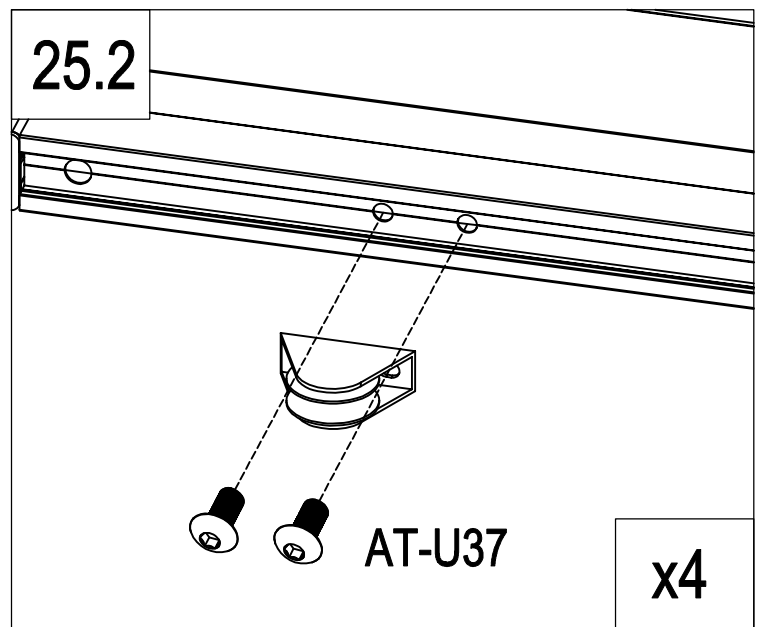
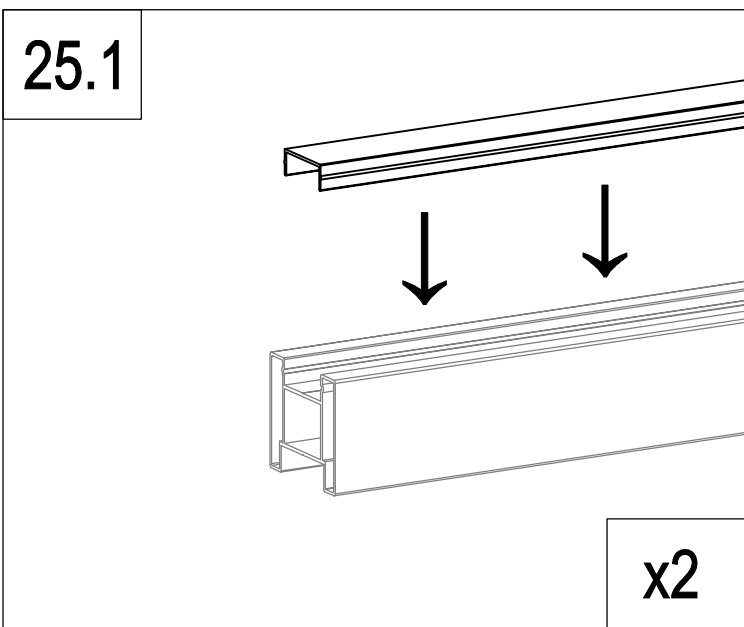
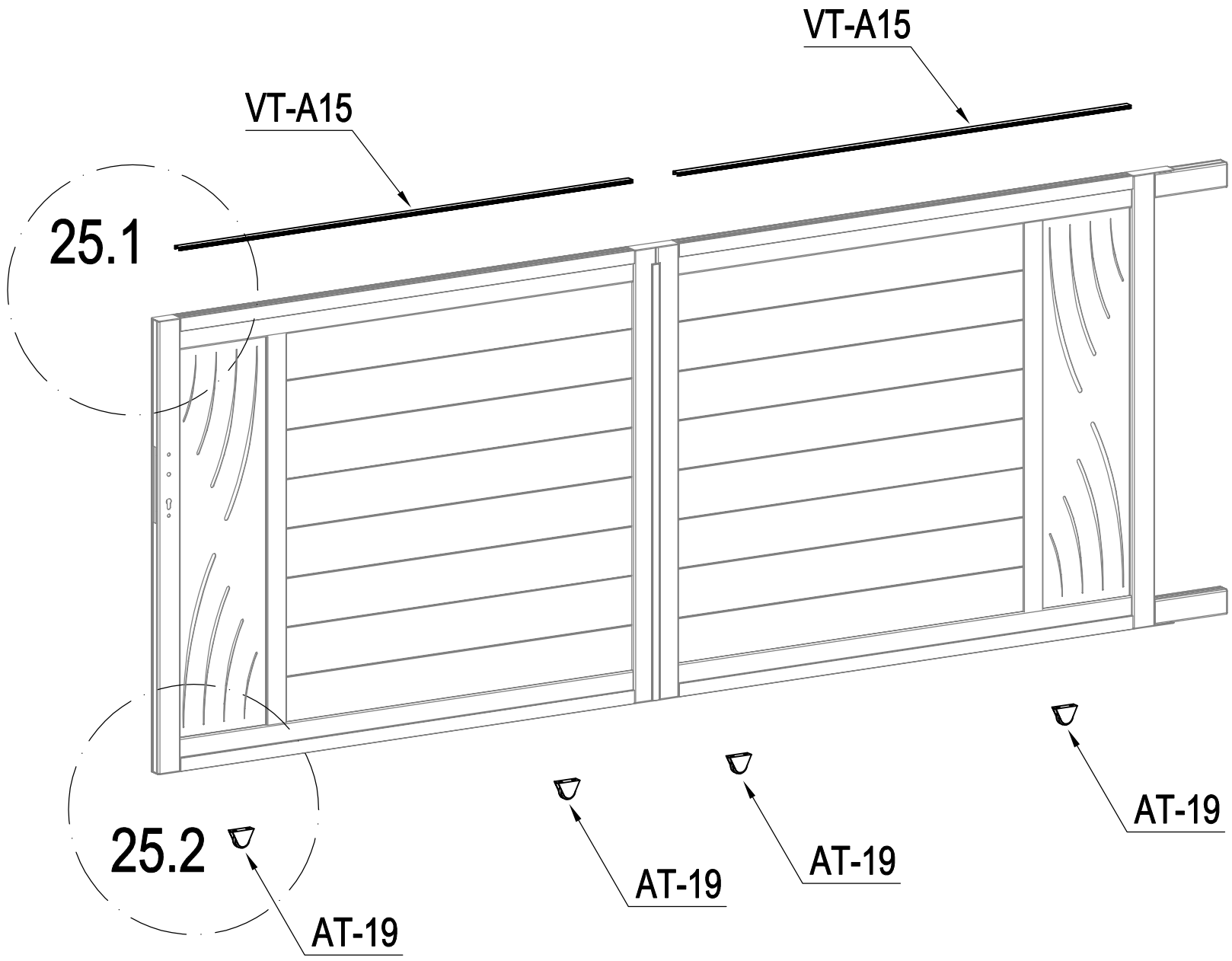

	VT-A15	2
	AT-19	4
	AT-U37	8

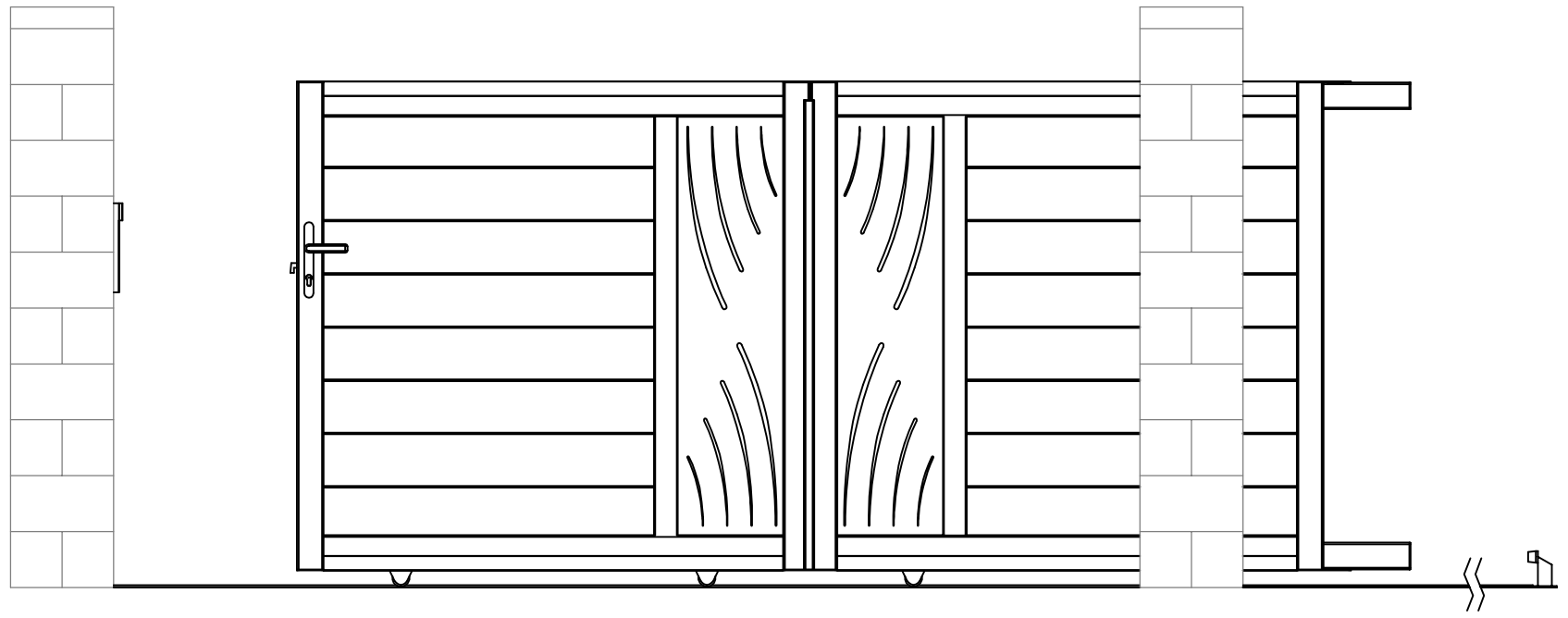

L : P51~56

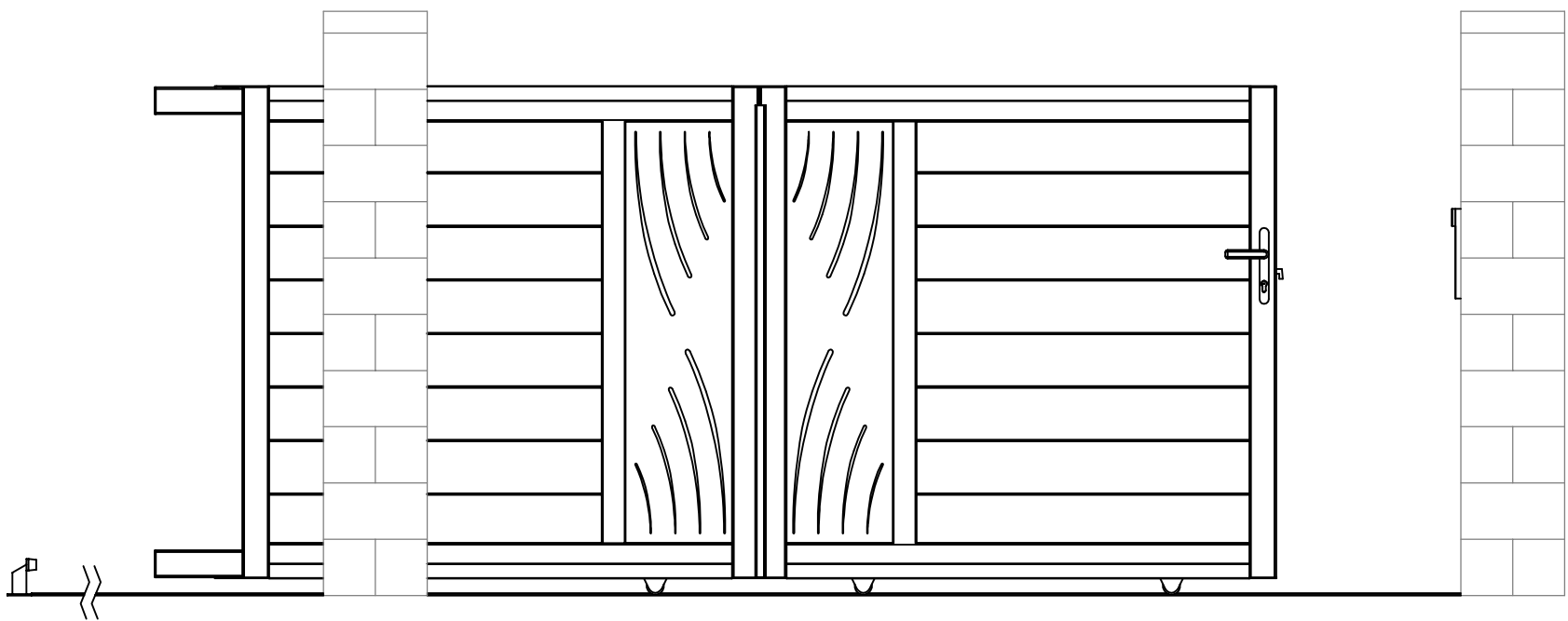

R : P57~62

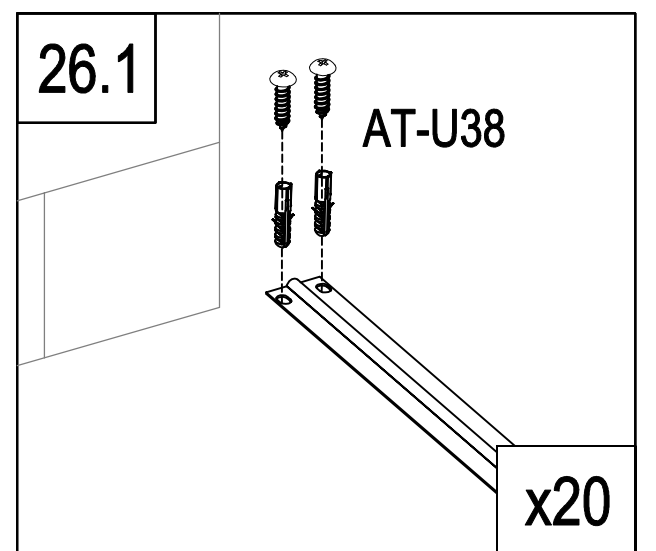
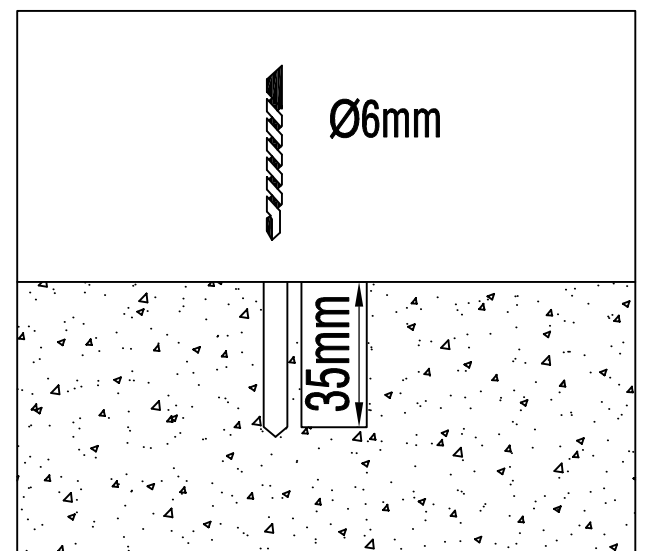
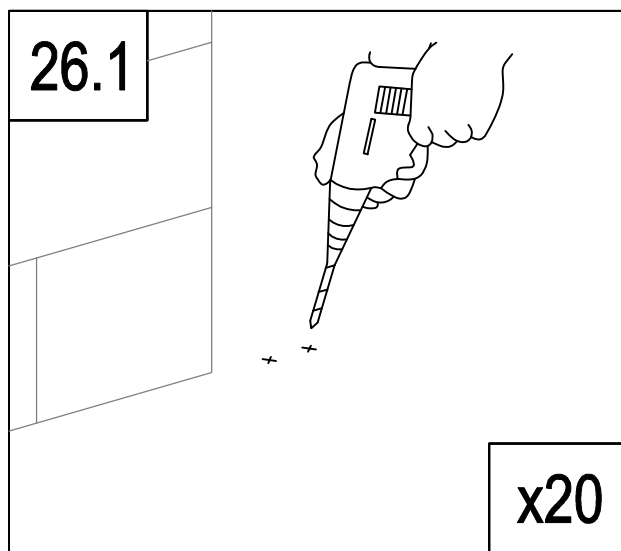
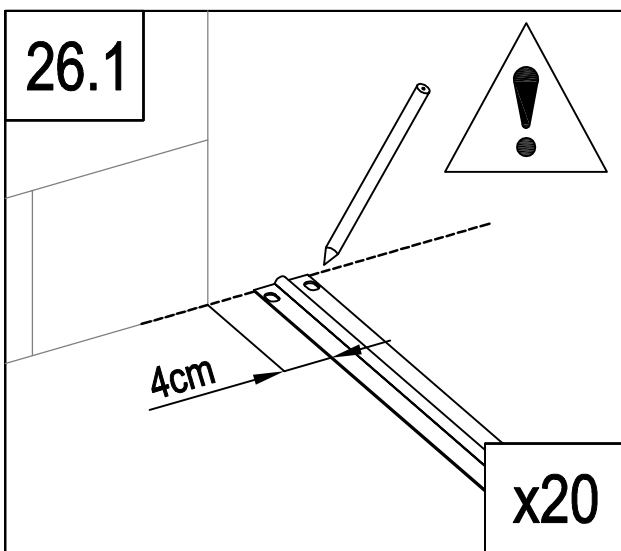
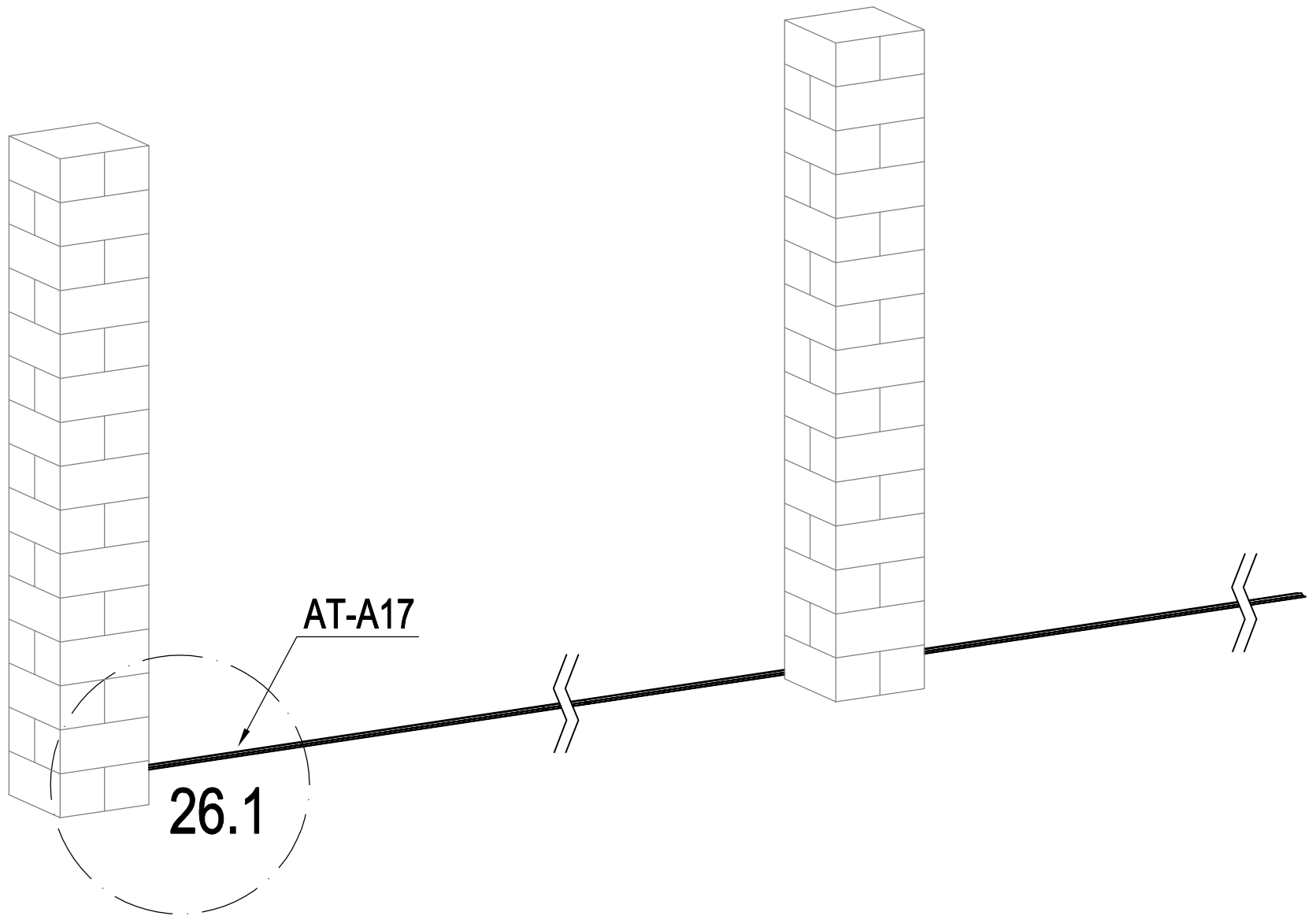

	AT-A17	5
	AT-U38	40

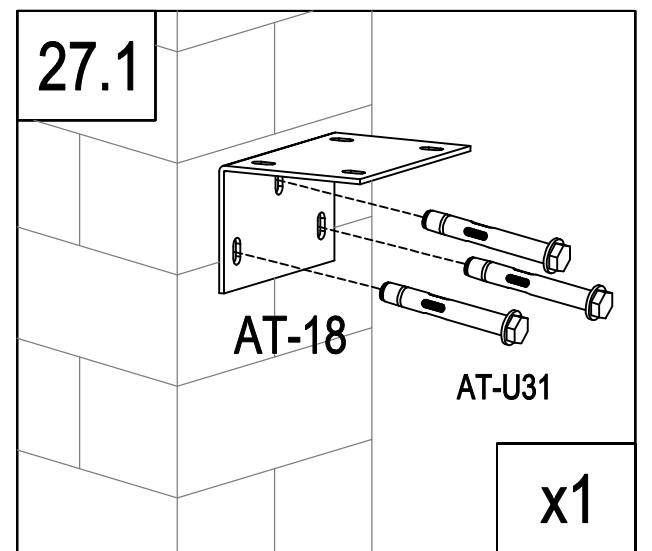
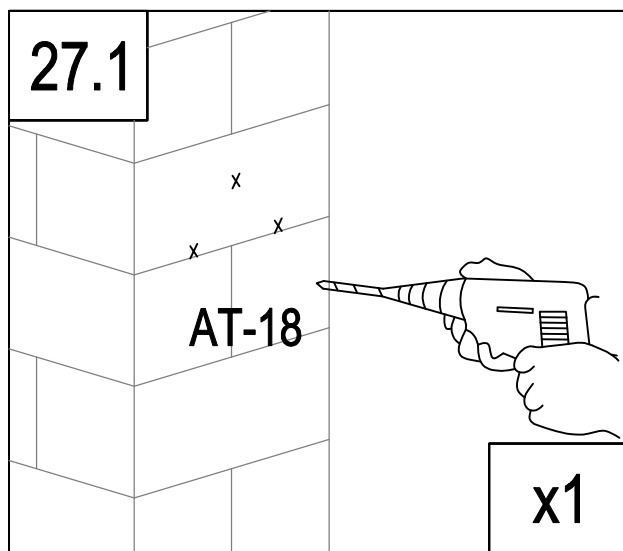
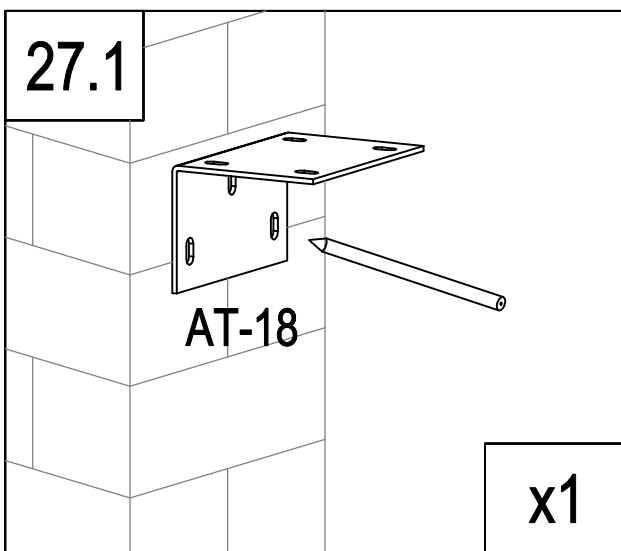
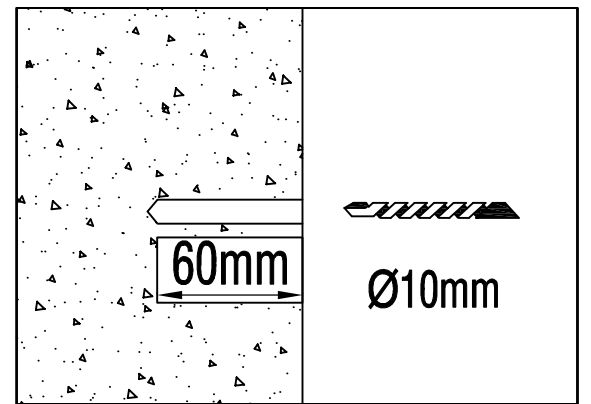
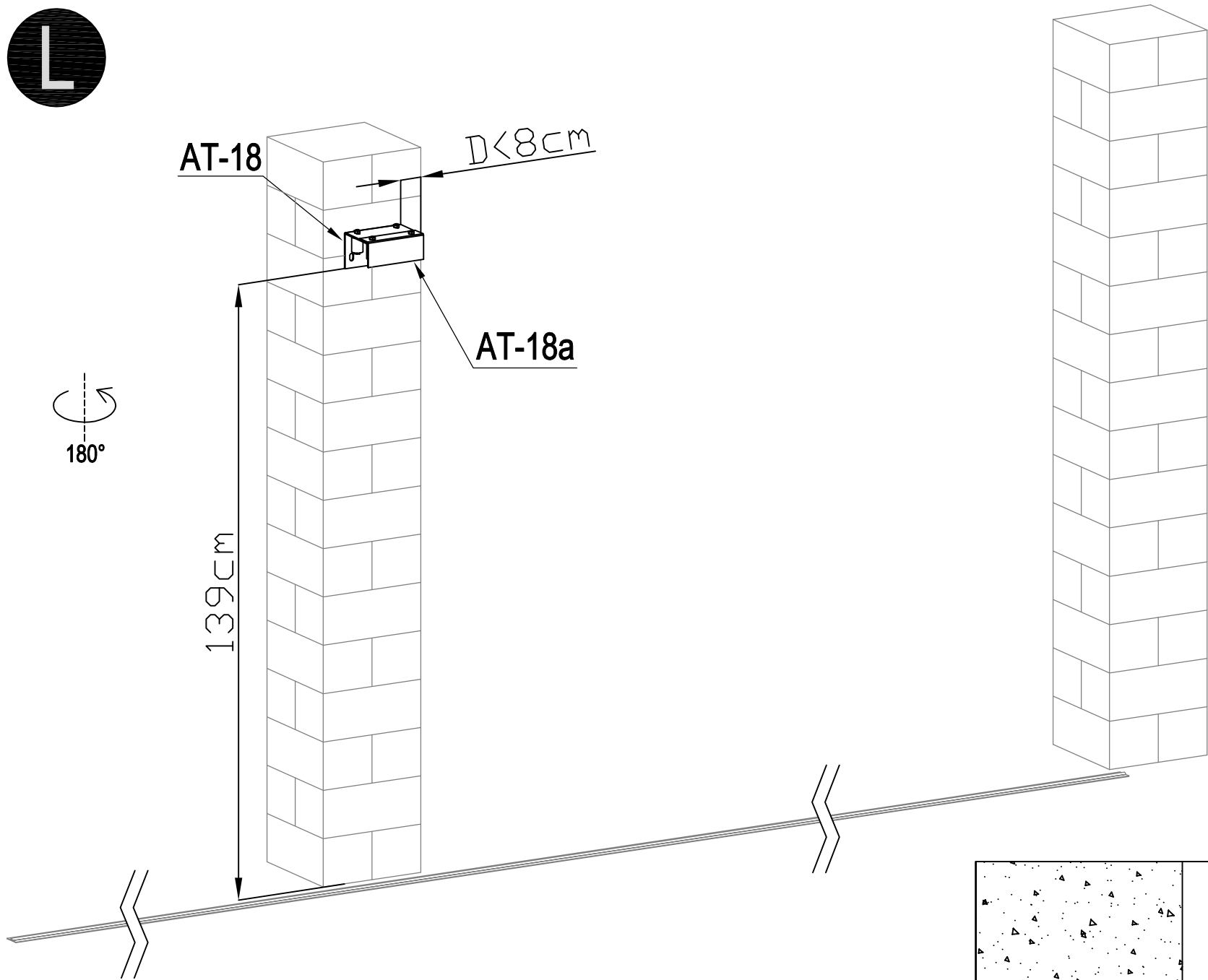

	AT-18	1
	AT-18a	1
	AT-20	4
	AT-U31	3

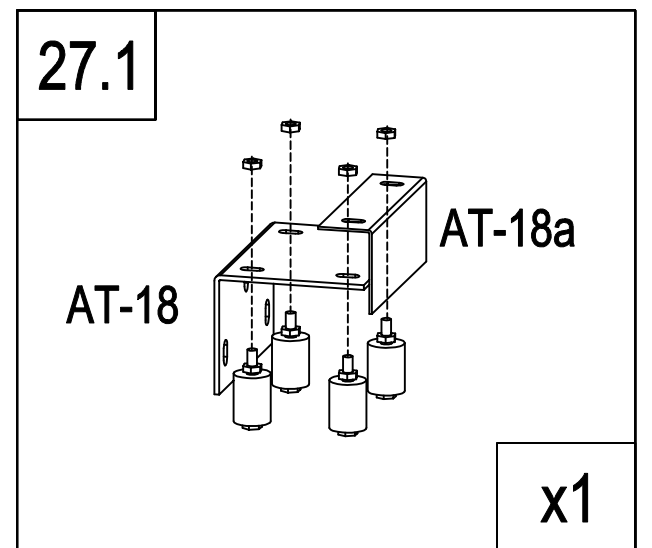
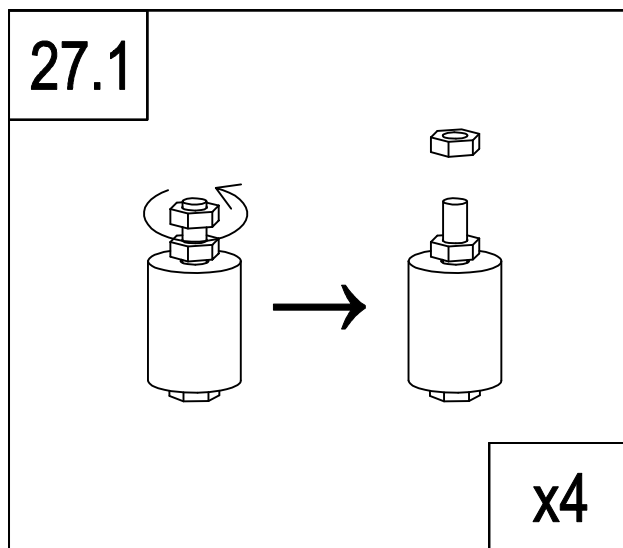

L

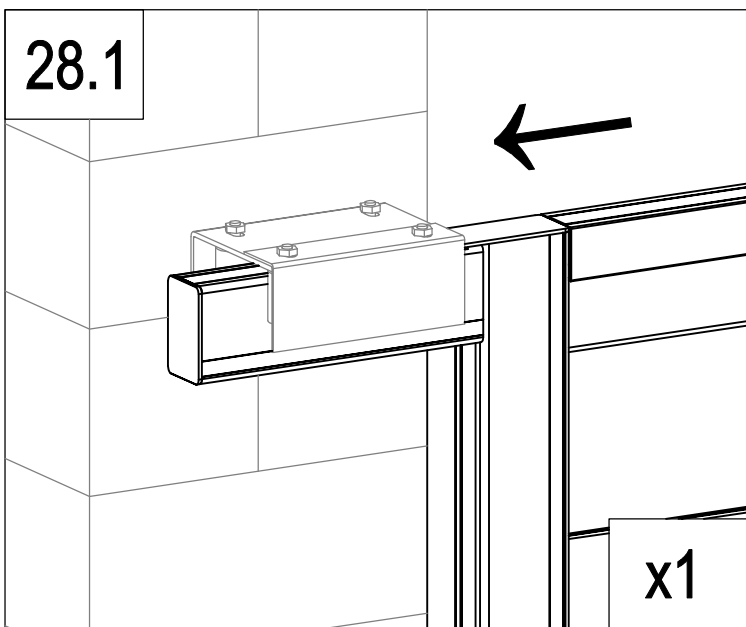
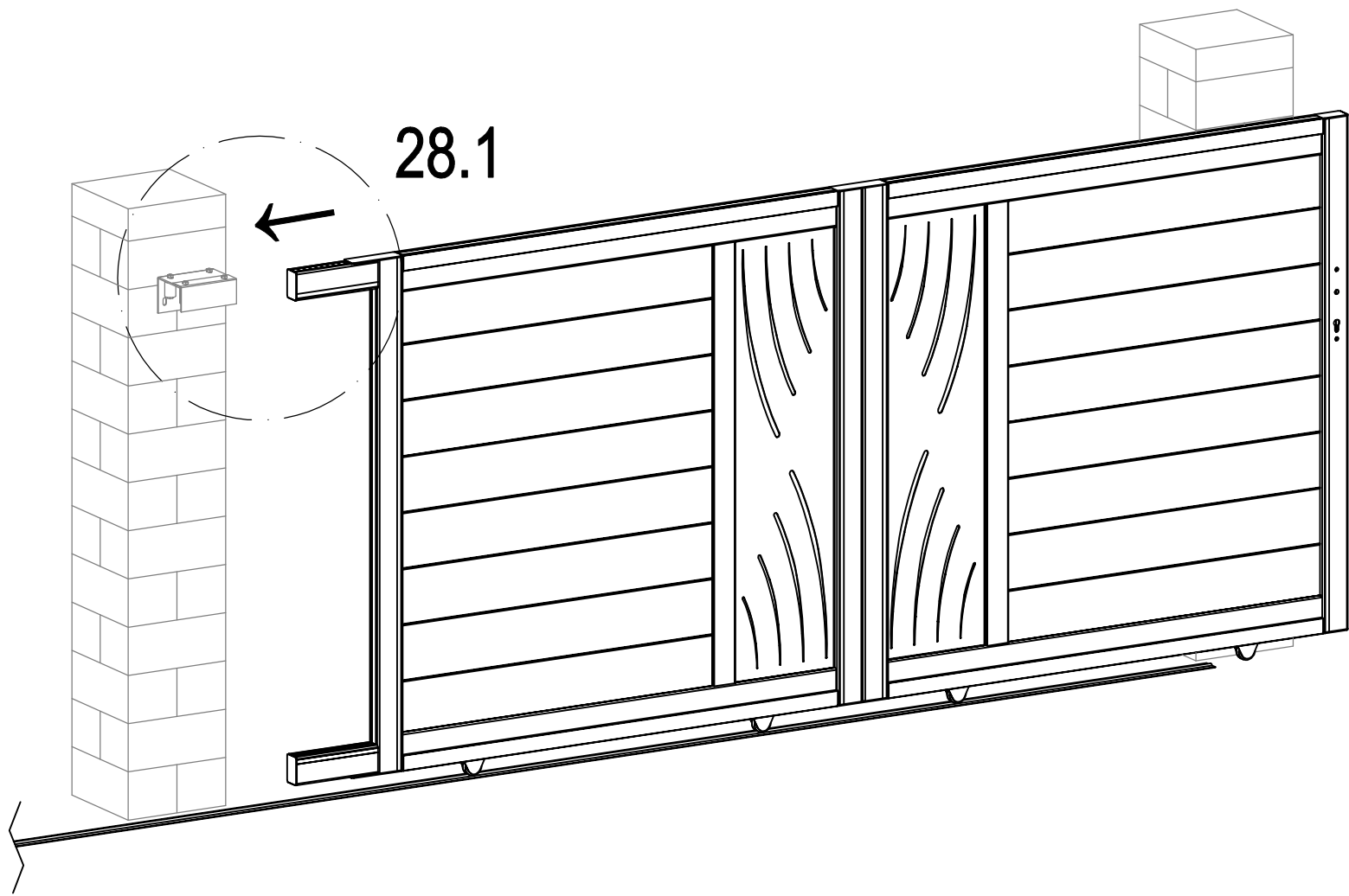

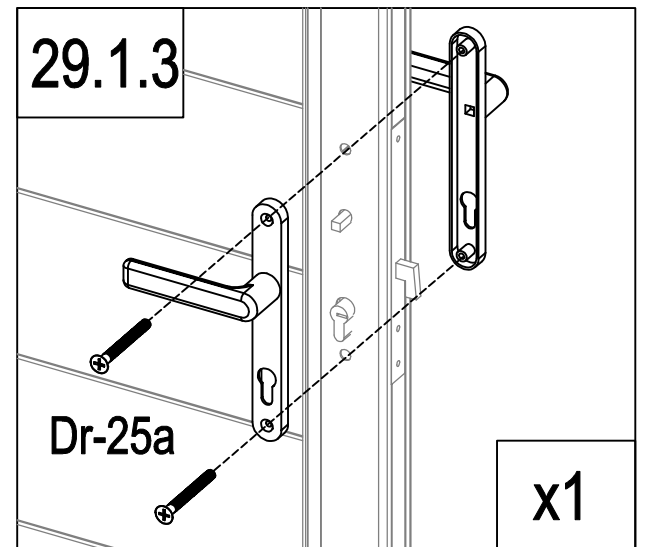
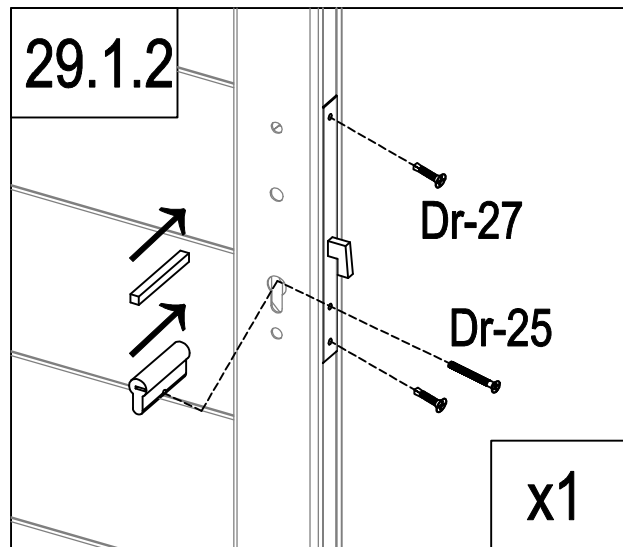
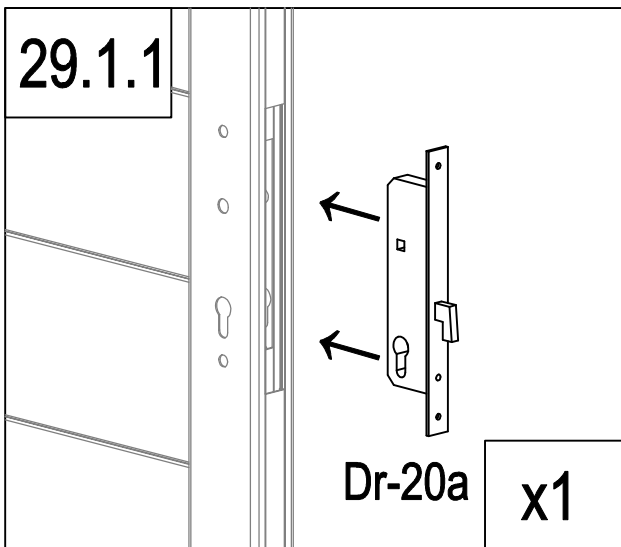
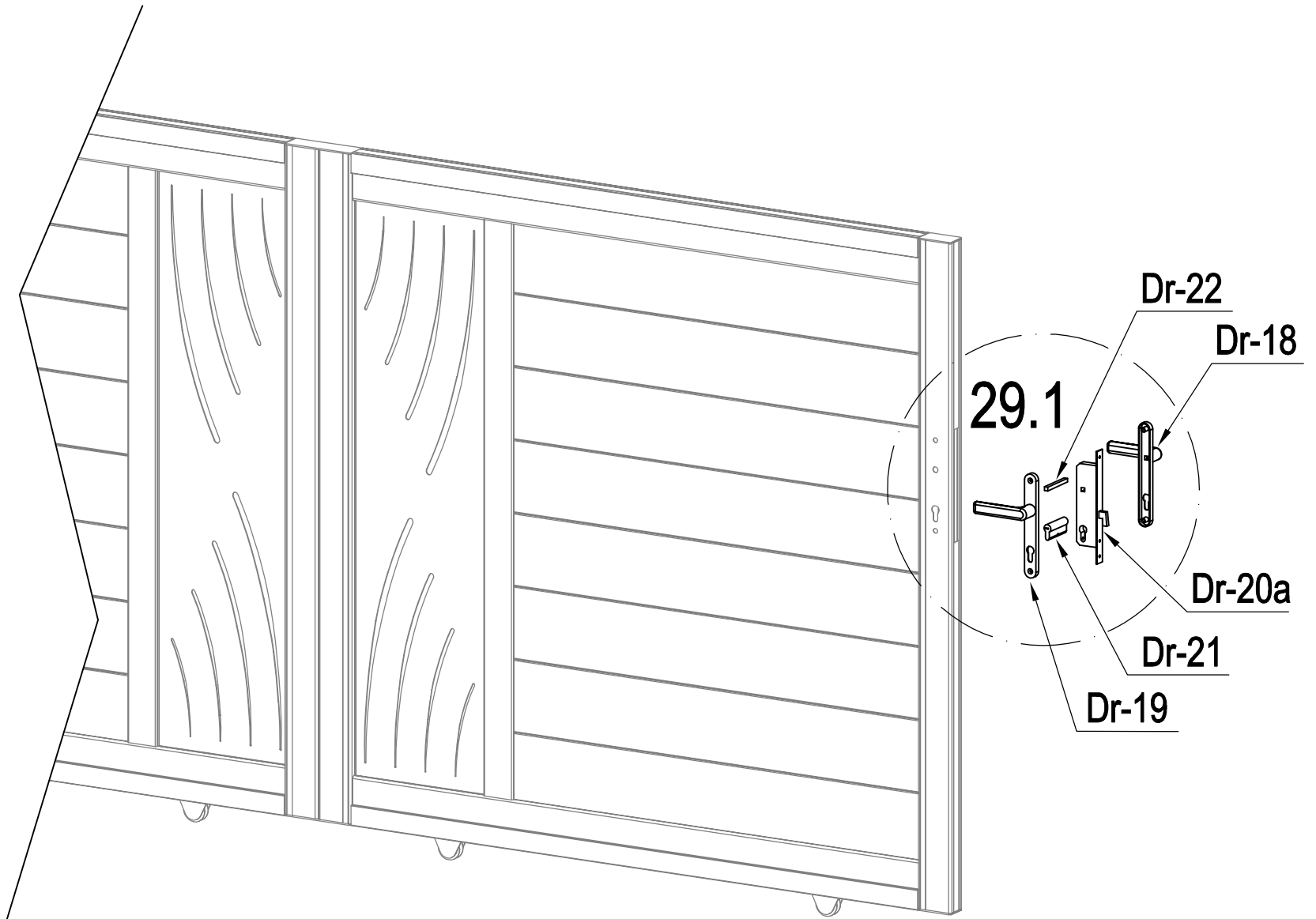

	Dr-20a	1
	Dr-21	1
	Dr-22	1
	Dr-25	1

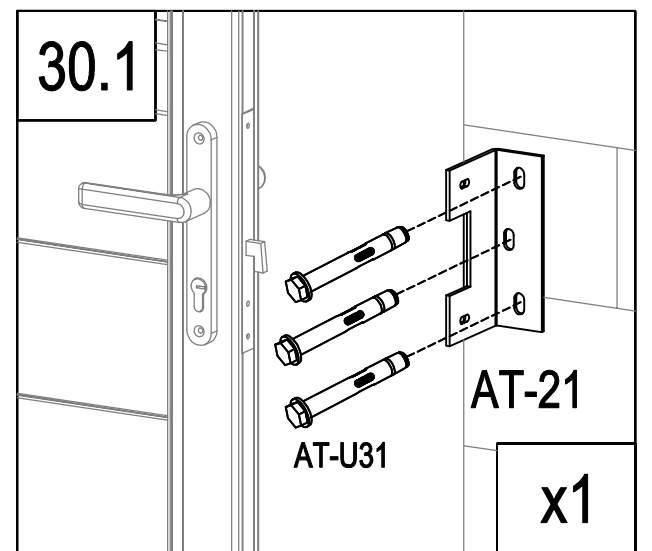
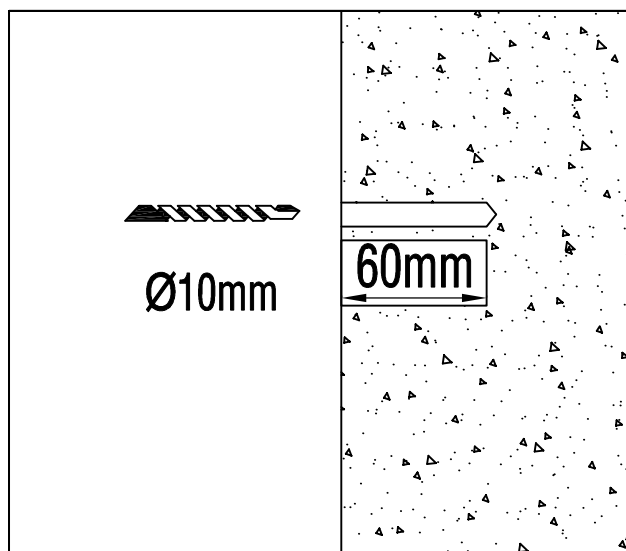
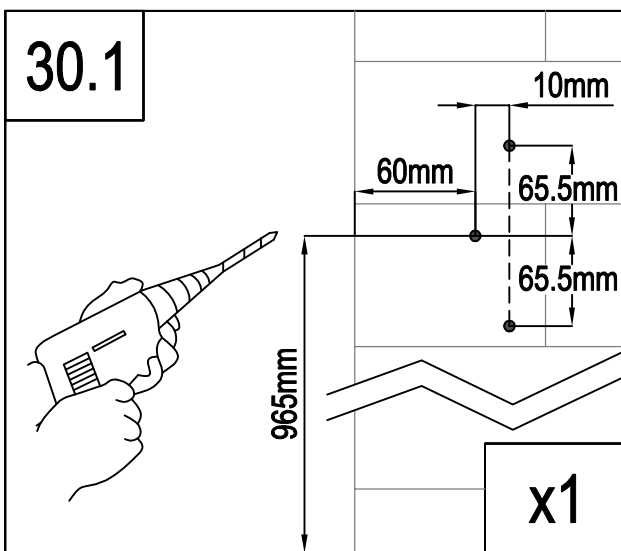
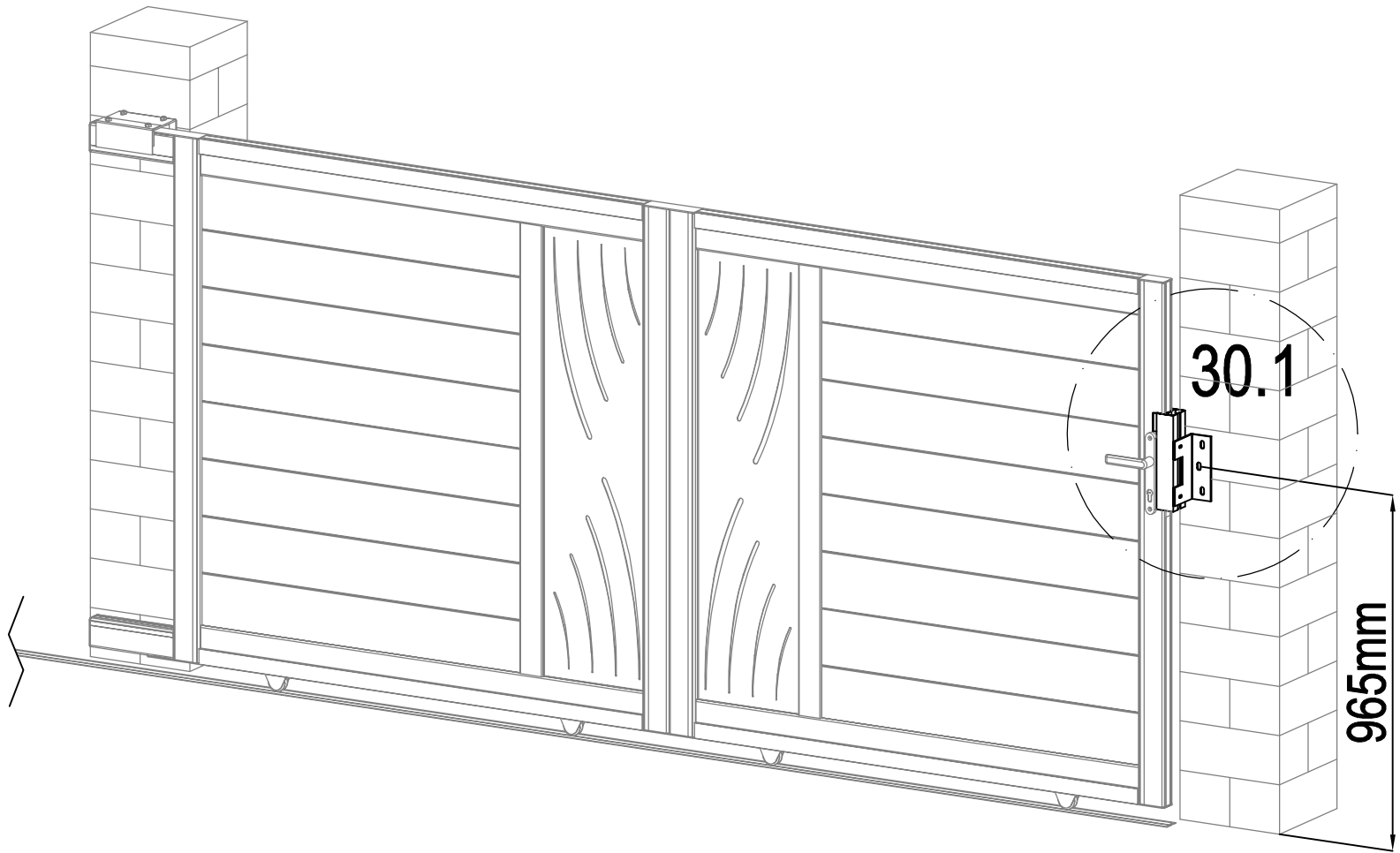

	Dr-18	1
	Dr-19	1
	Dr-25a	2
	Dr-27	2

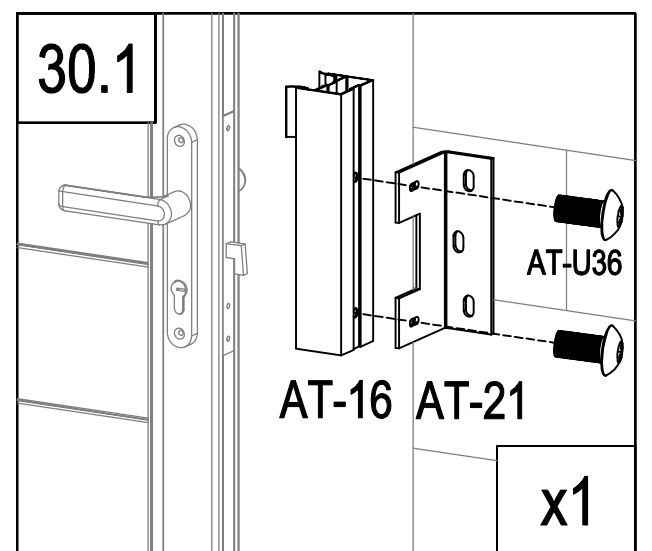

	AT-16	1
	AT-21	1
	AT-U36	2
	AT-U31	3

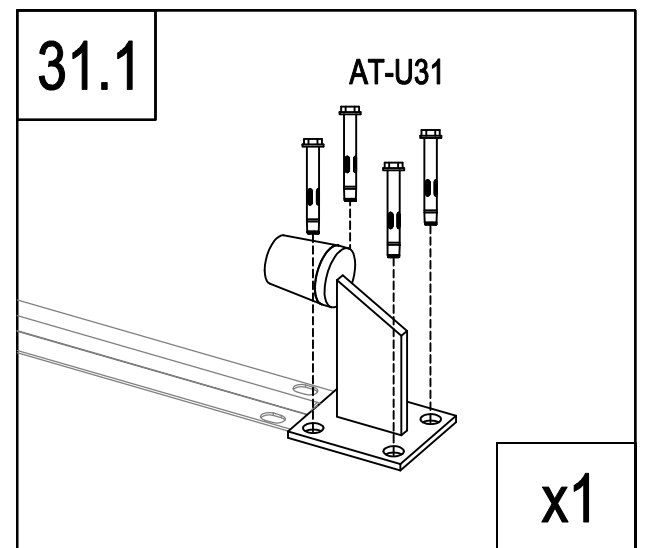
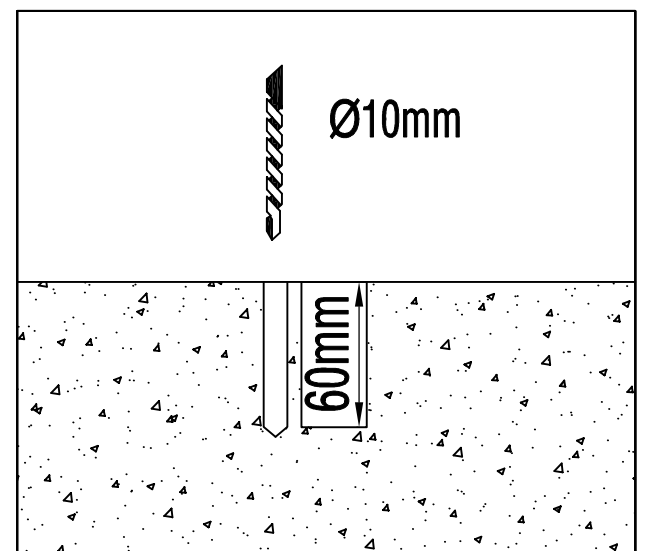
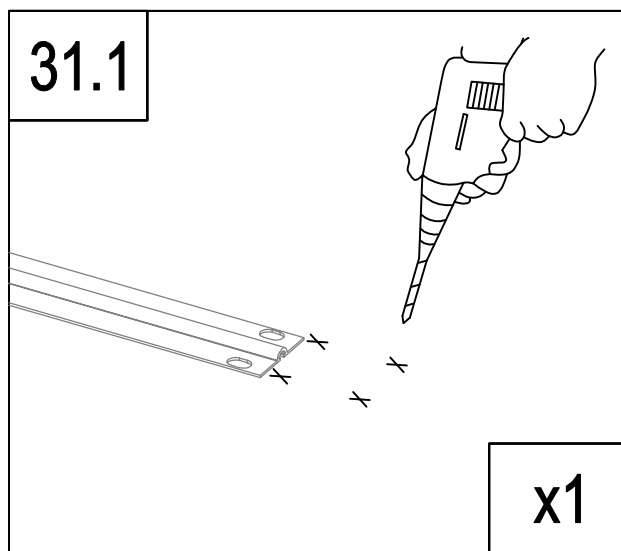
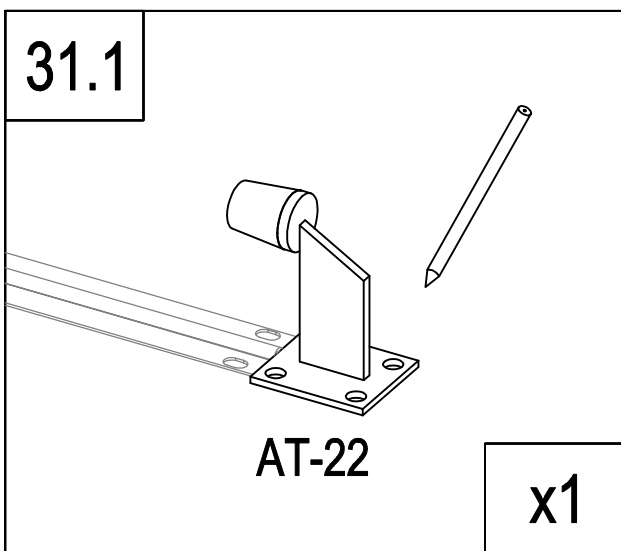
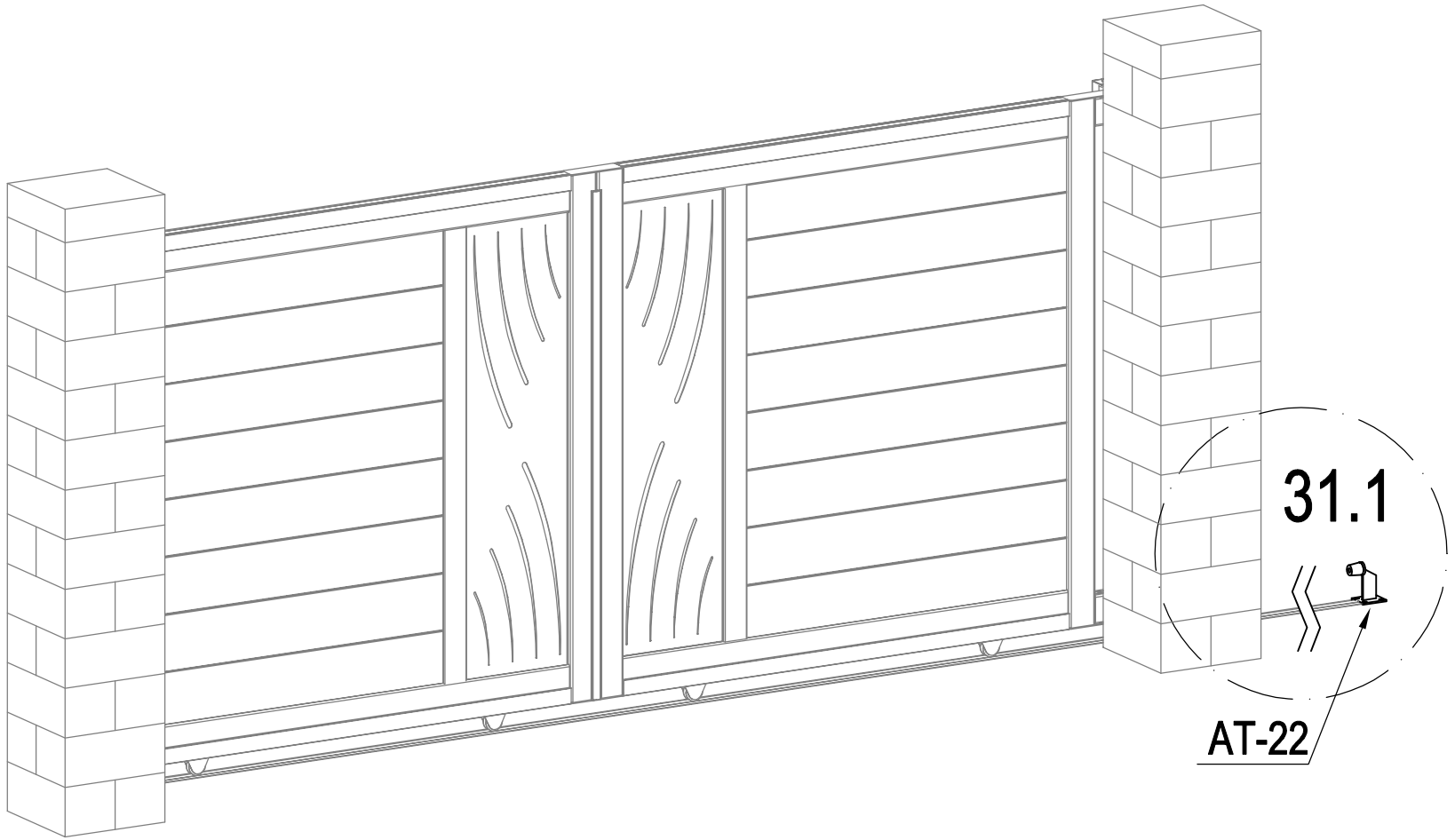



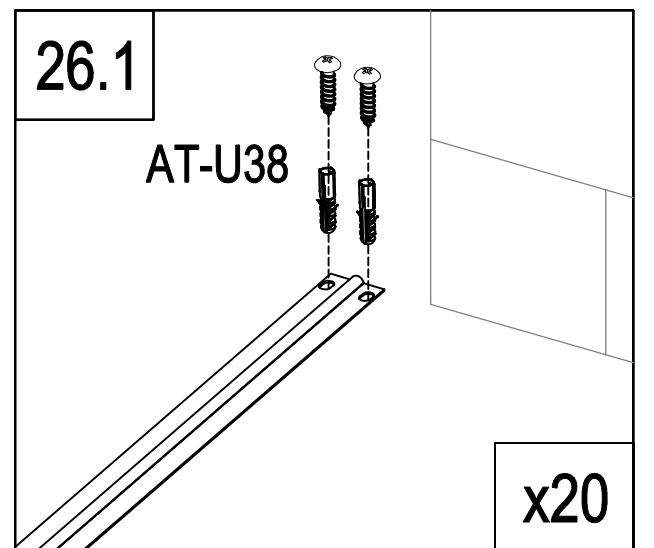
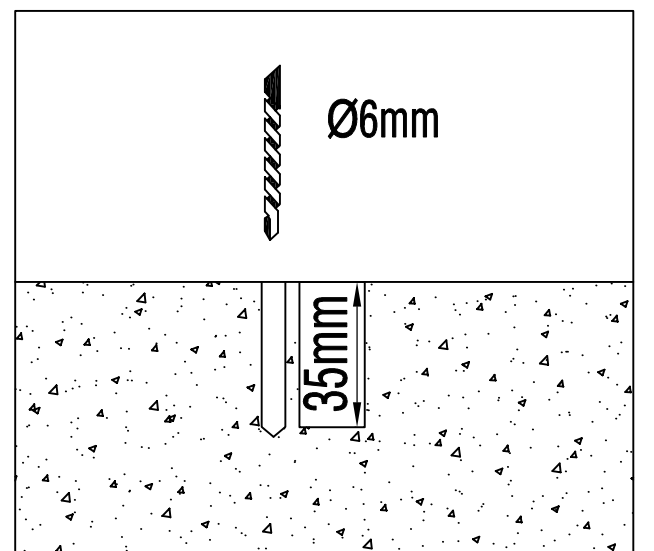
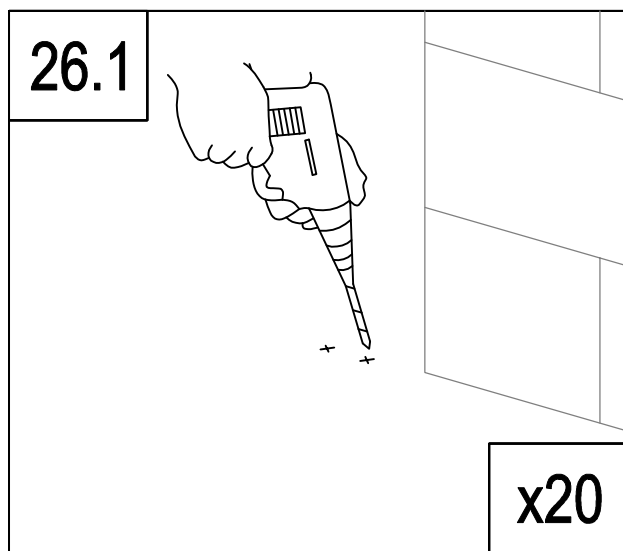
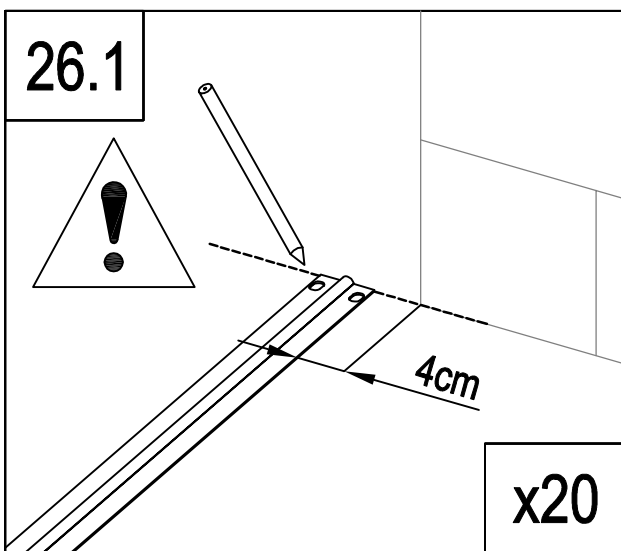
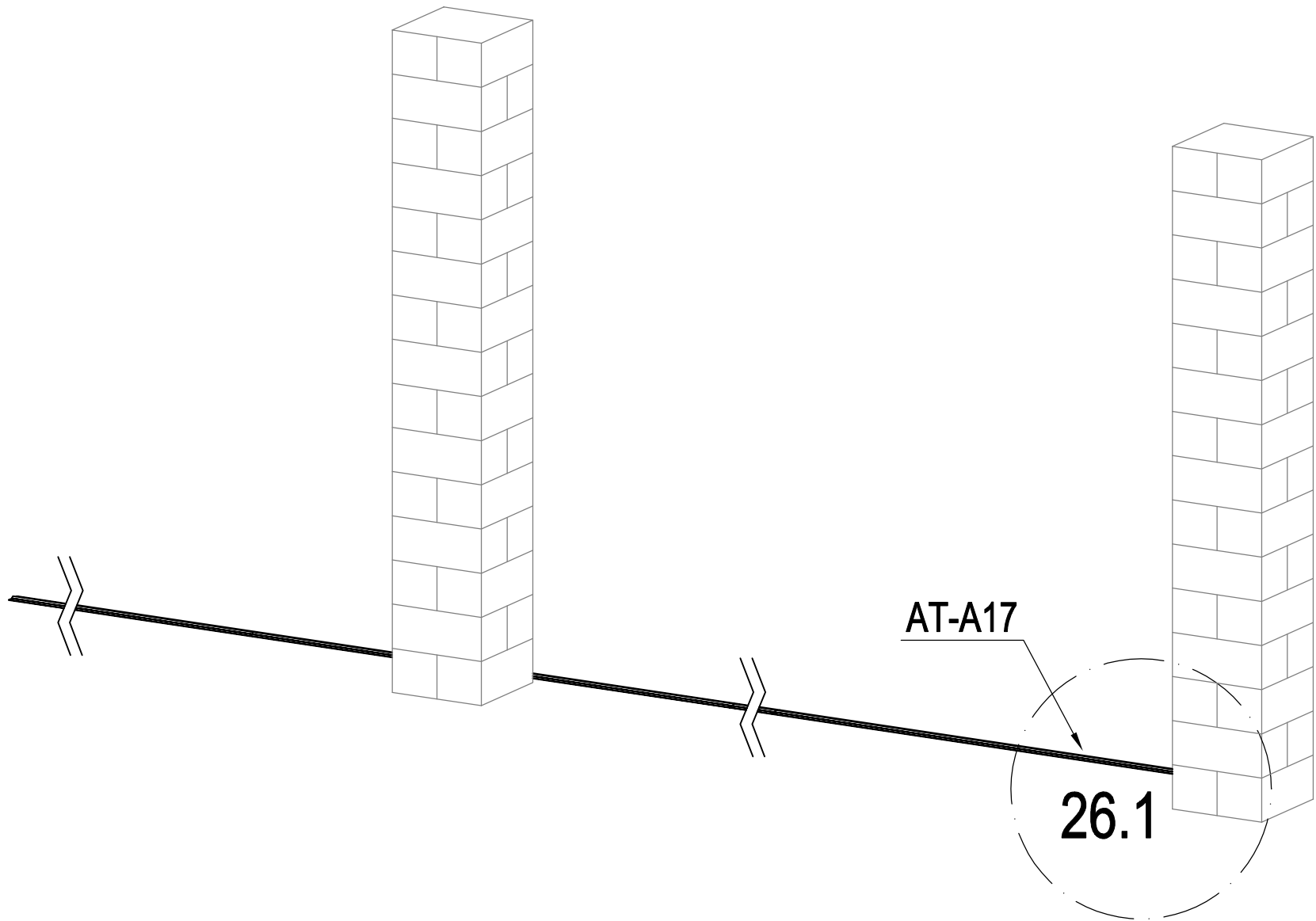

	AT-22	1
	AT-U31	4

R



	AT-A17	5
	AT-U38	40

R

180°

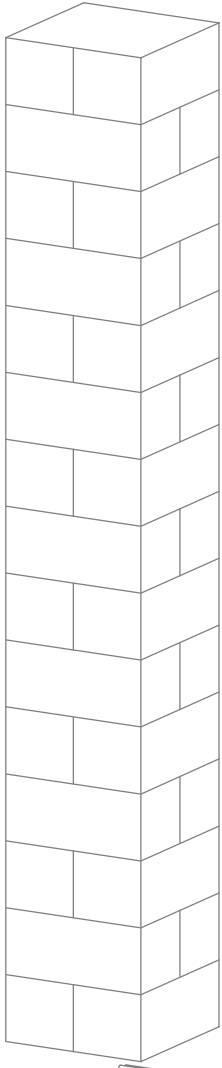

$D < 8\text{cm}$ AT-18

AT-18a

139cm

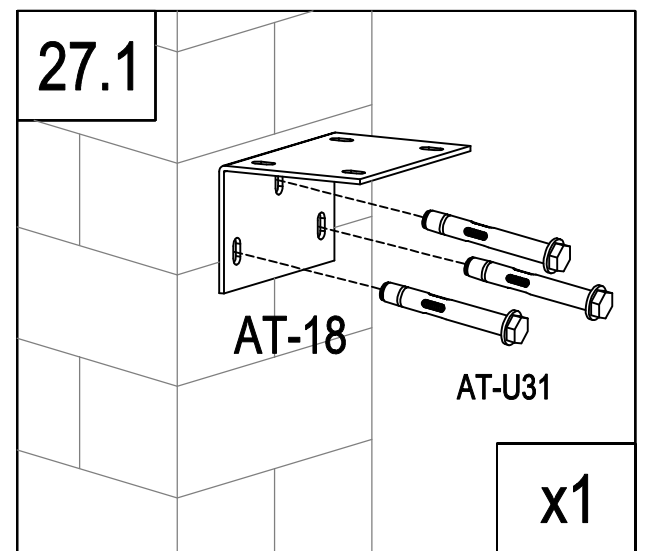
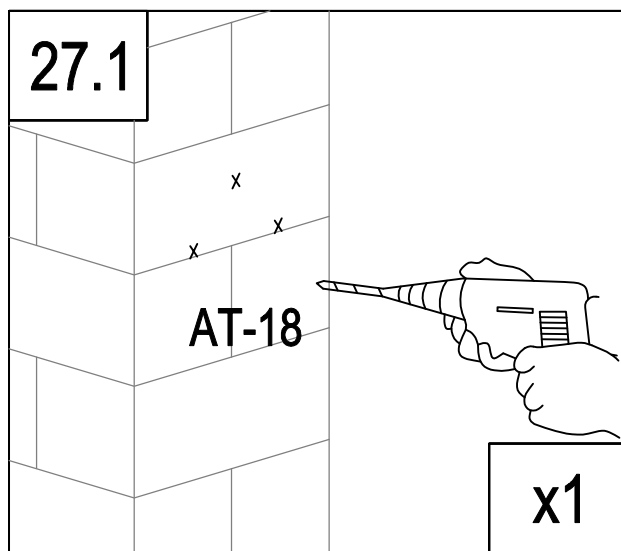
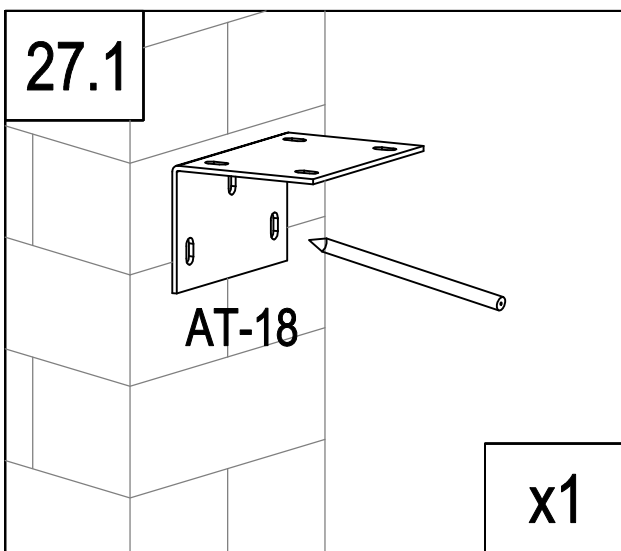
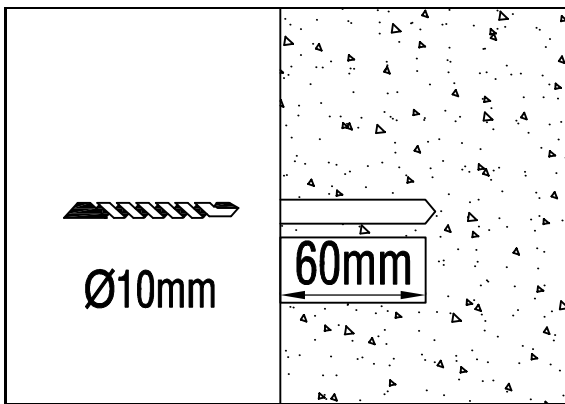

	AT-18	1
	AT-18a	1
	AT-20	4
	AT-U31	3

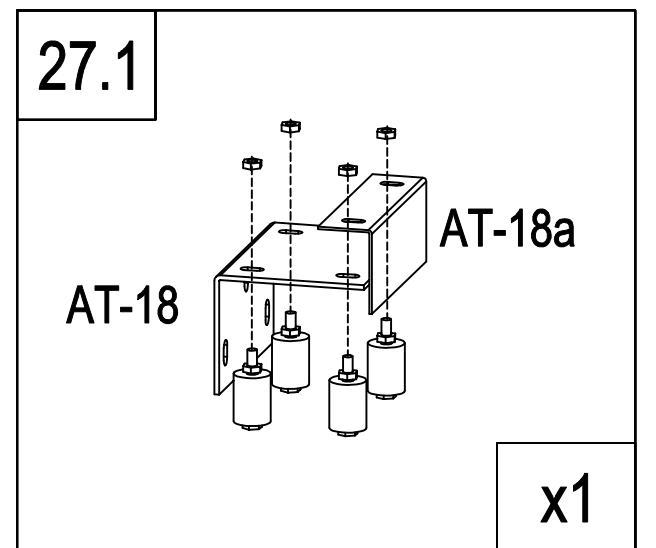
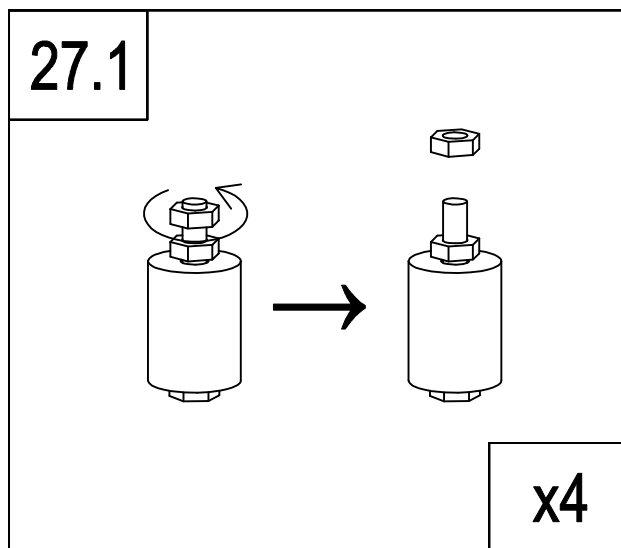

R

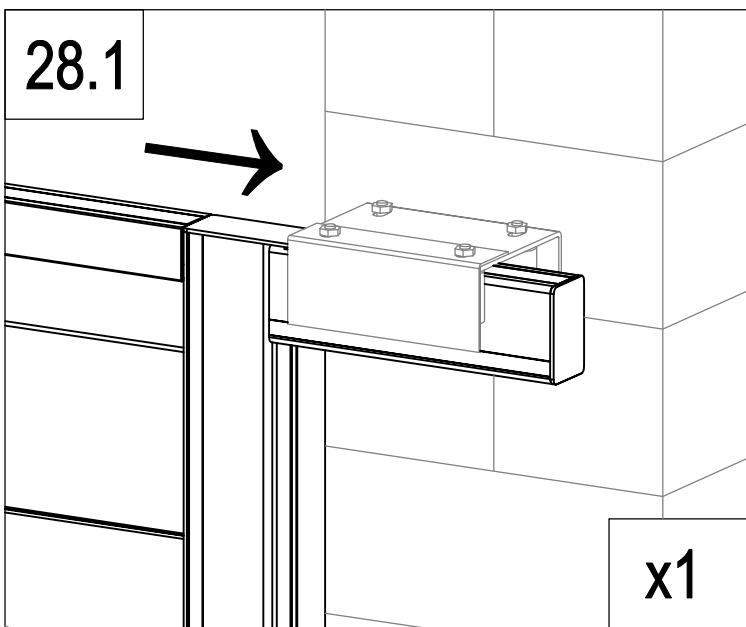
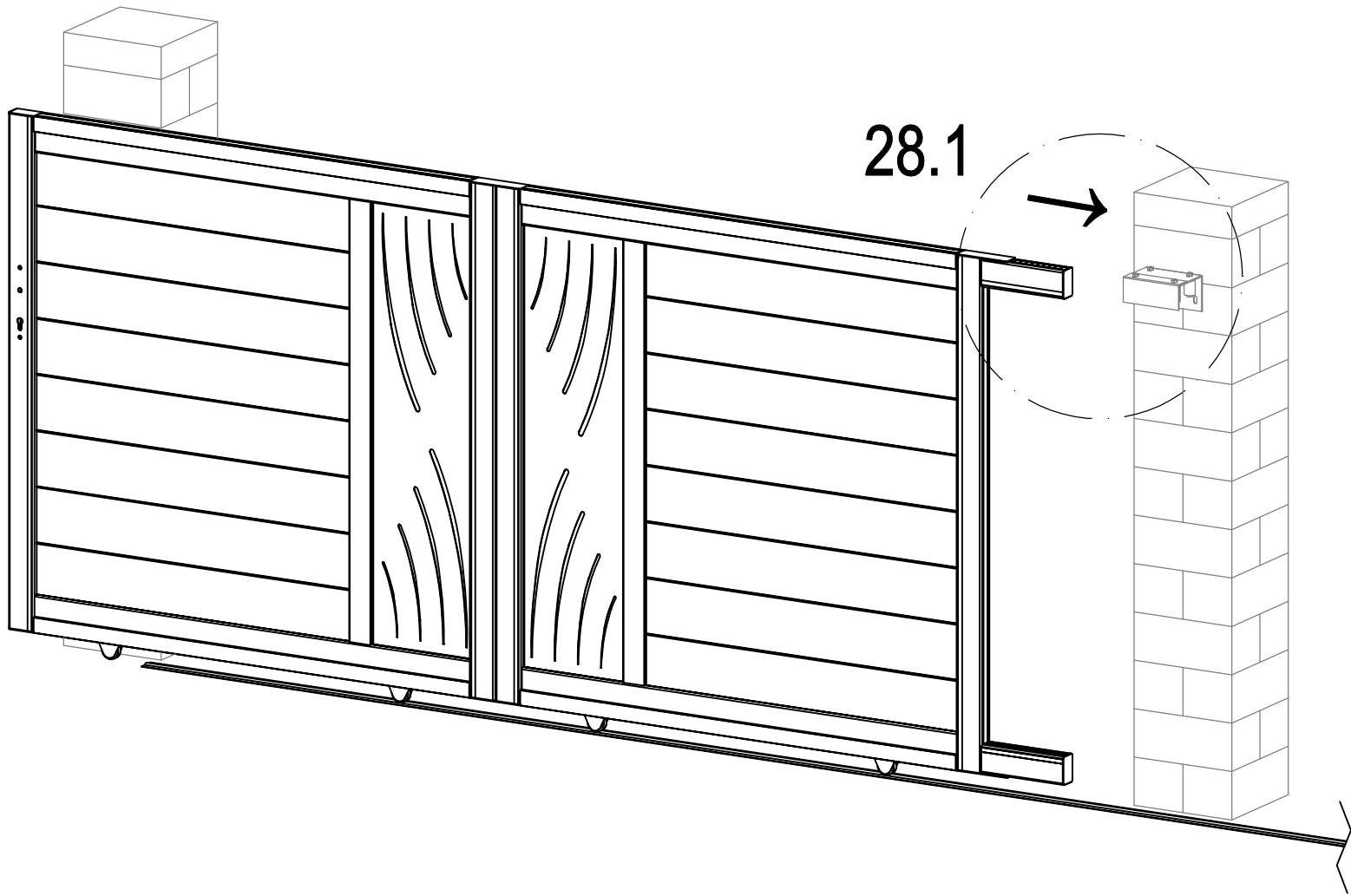

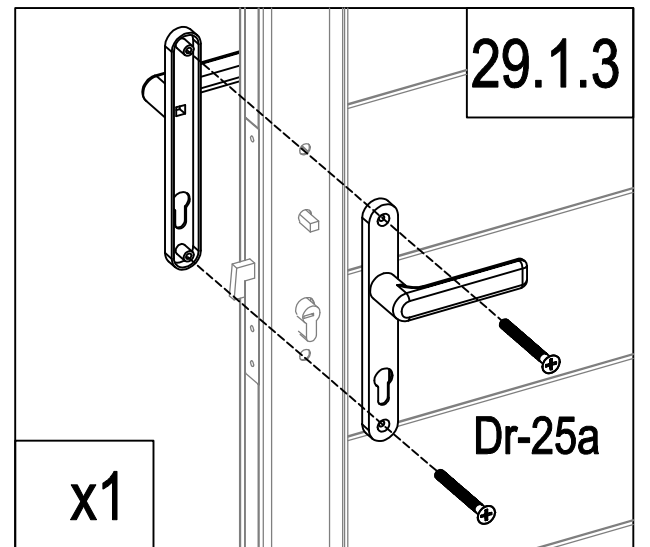
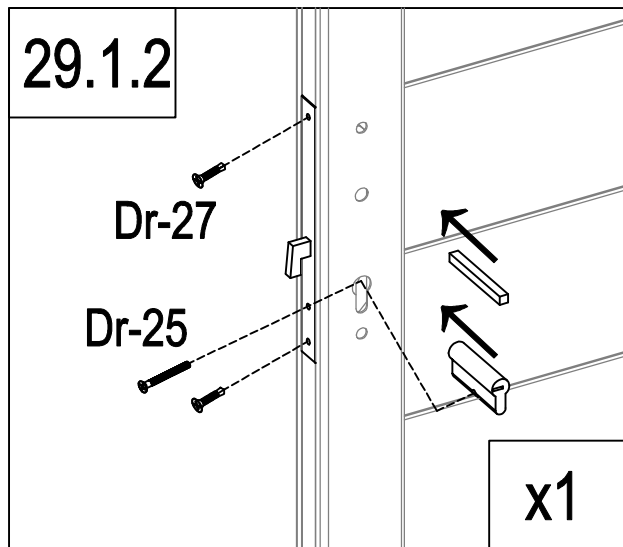
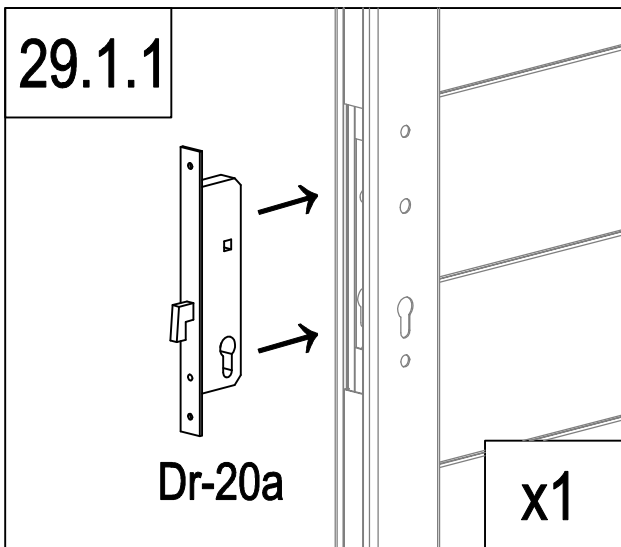
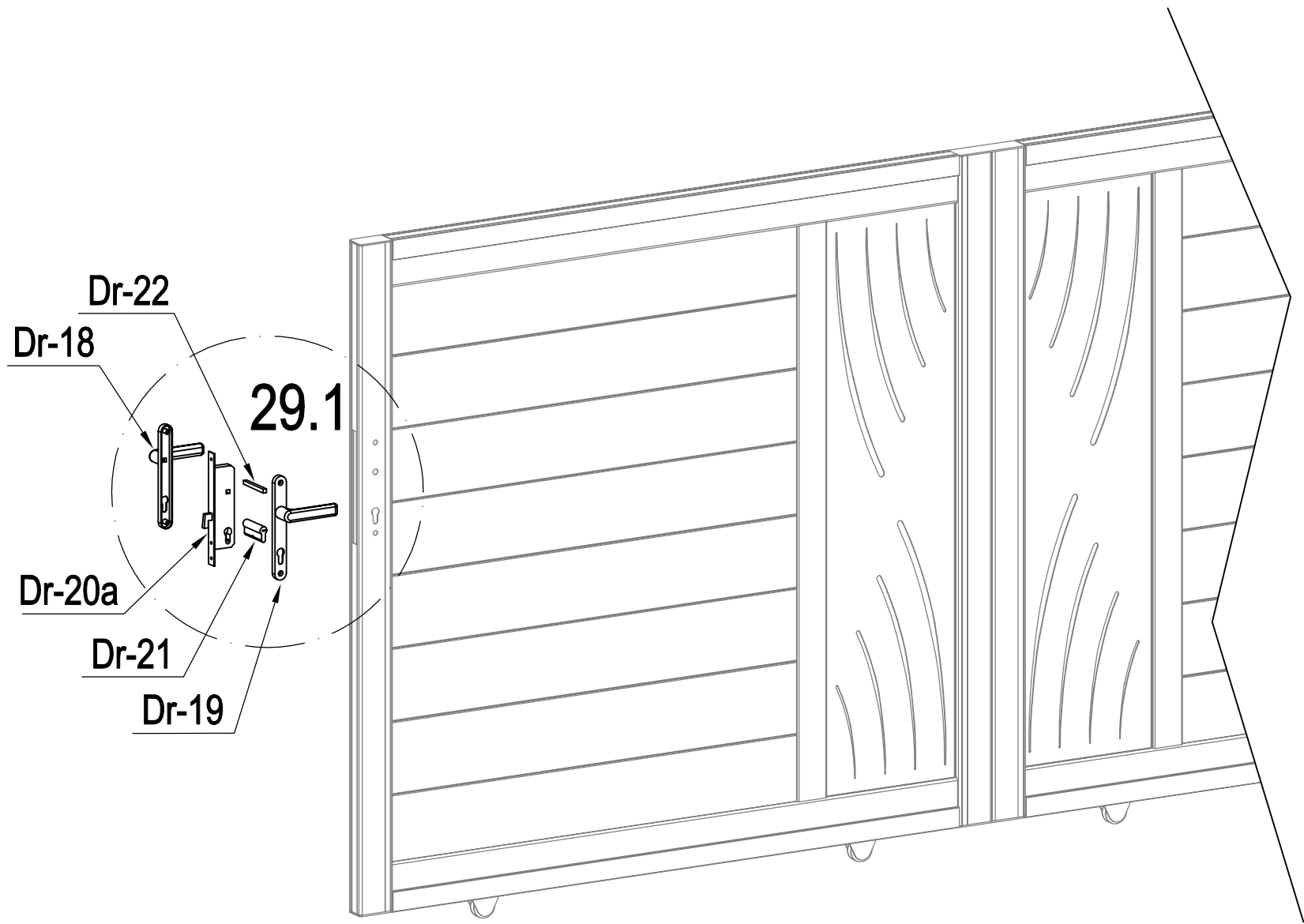

	Dr-20a	1
	Dr-21	1
	Dr-22	1
	Dr-25	1

	Dr-18	1
	Dr-19	1
	Dr-25a	2
	Dr-27	2

R

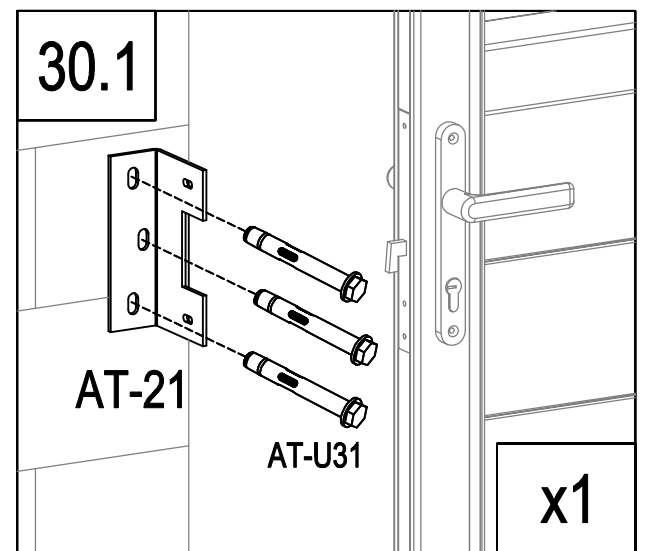
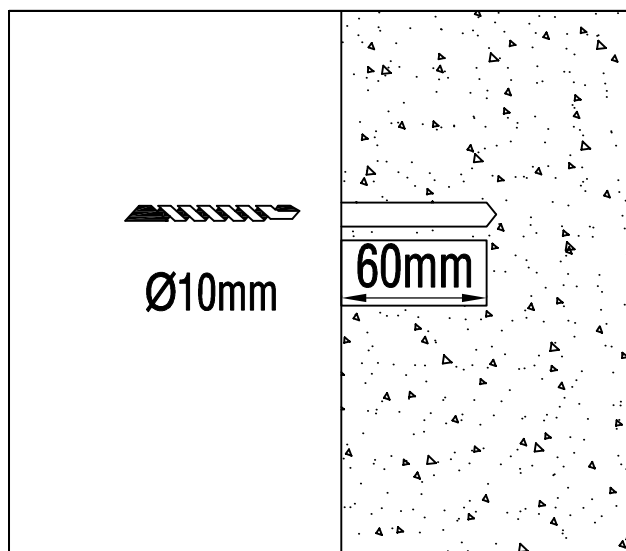
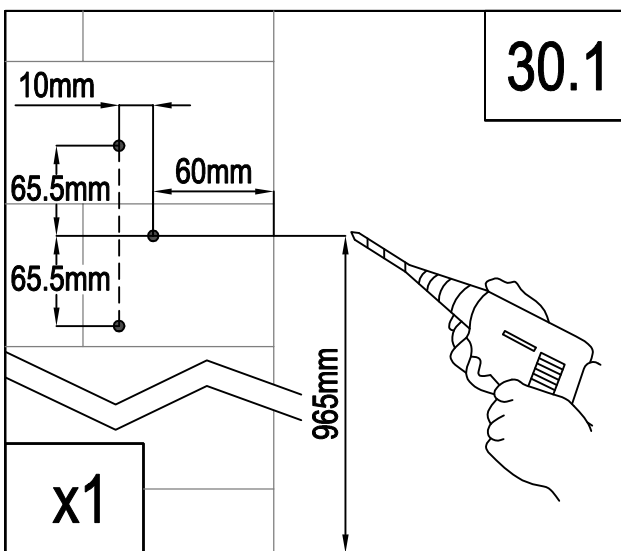
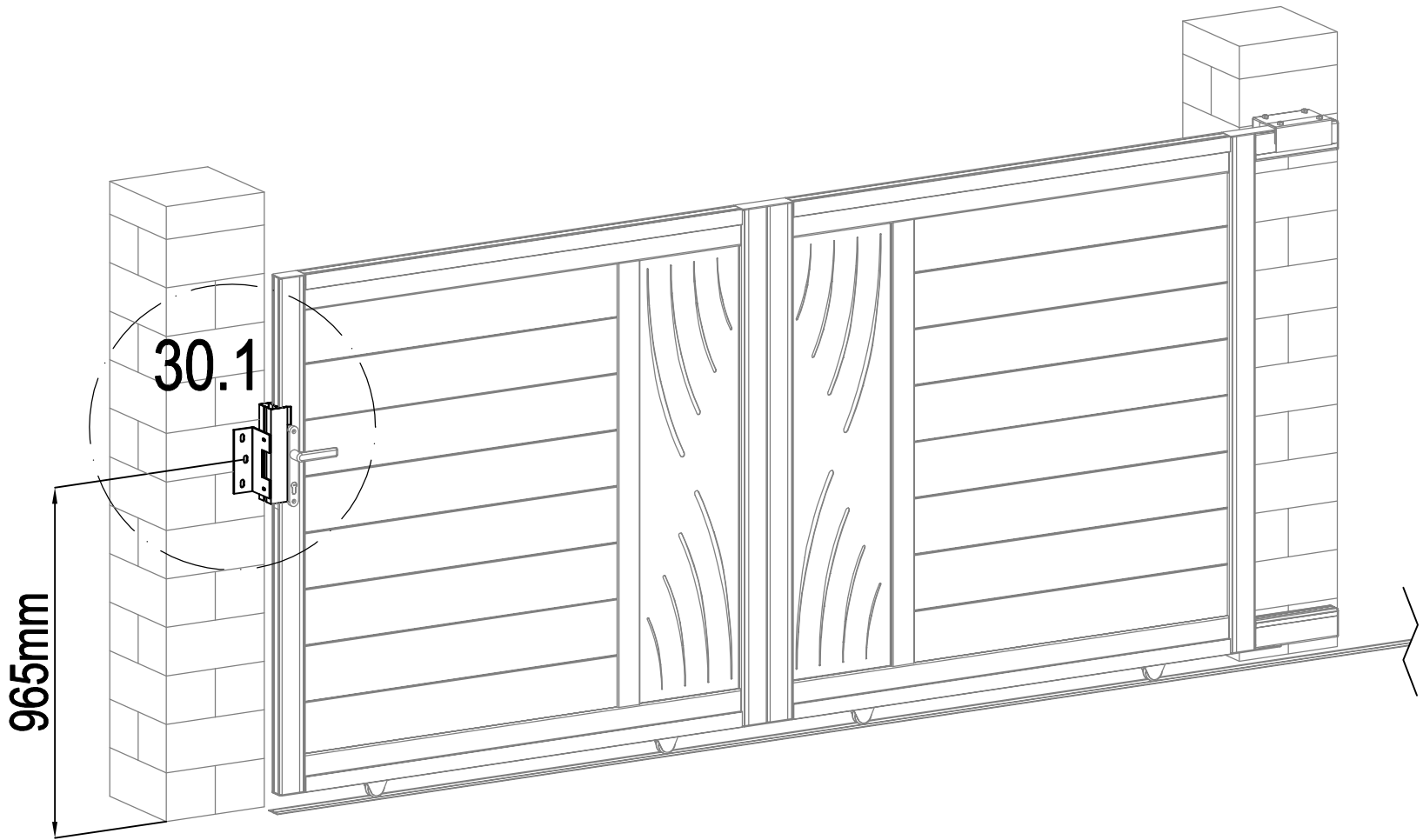

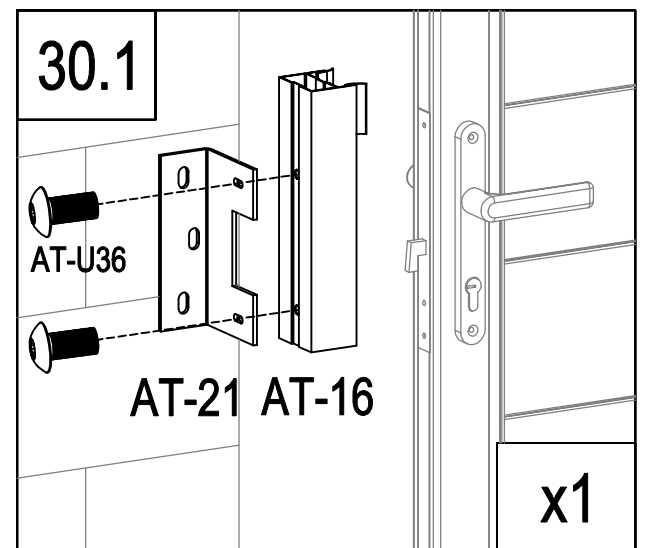

	AT-16	1
	AT-21	1
	AT-U36	2
	AT-U31	3

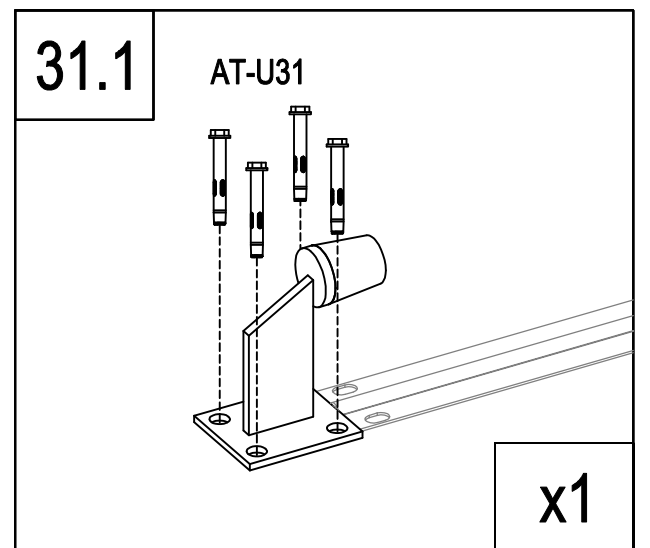
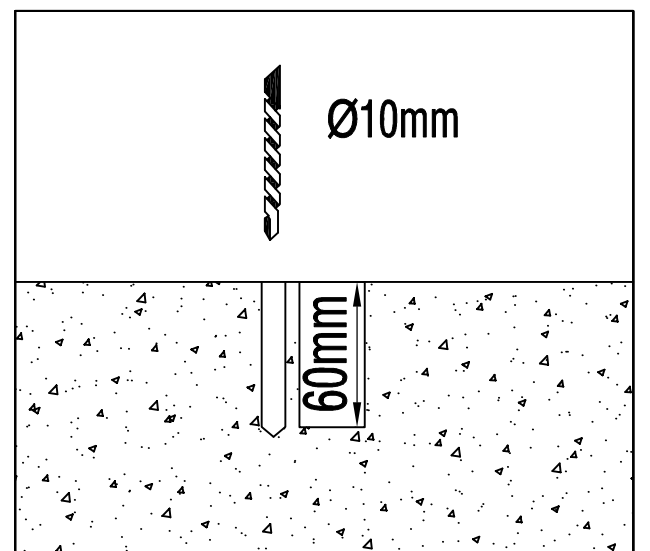
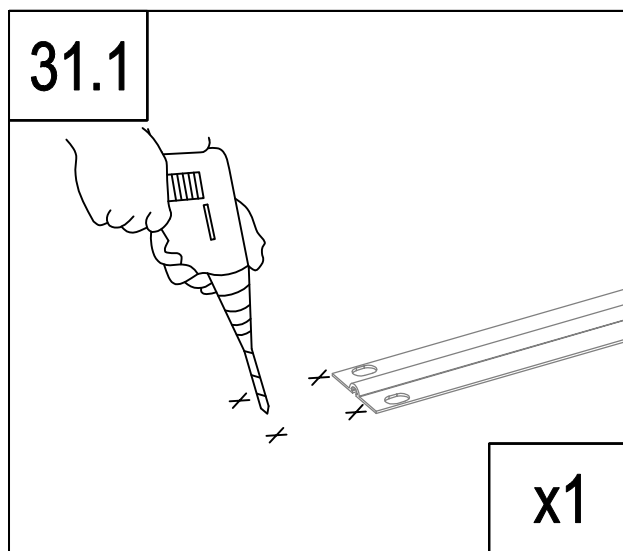
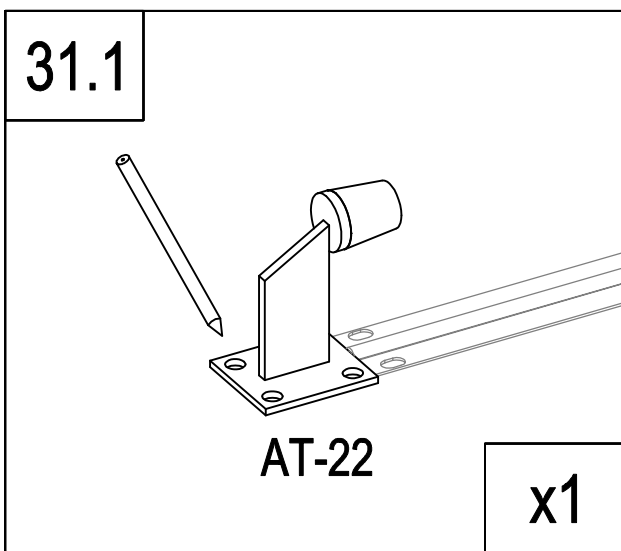
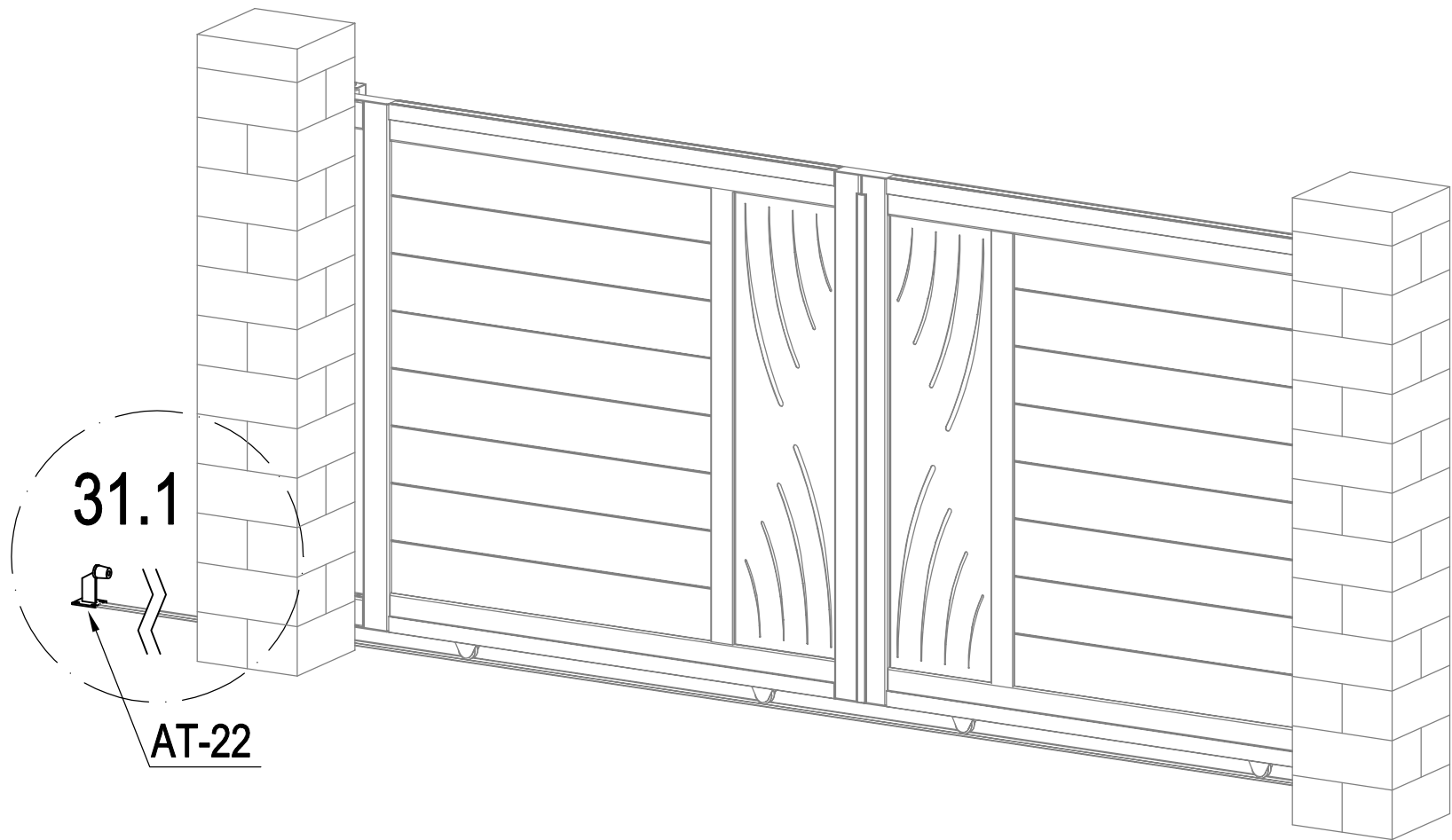

R



	AT-22	1
	AT-U31	4