

CASANOVO

VOGEL 450C140

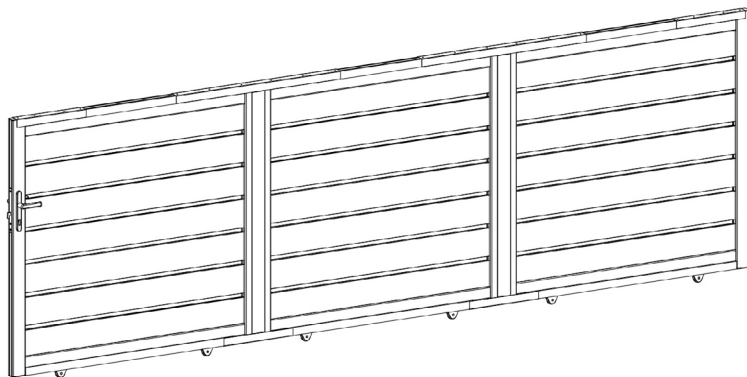

COM-001097 [x1]

COM-001098 [x1]

COM-001099 [x1]

COM-001211 [x1]



7-8H



X 2



INSTRUCTION MANUAL / NOTICE DE MONTAGE / MONTAGEANLEITUNG / MANUAL DE MONTAJE / MANUAL DE MONTAGEM / MANUALE DI MONTAGGIO /
MONTAGEHANDLEIDING / INSTRUKCJA MONTAŻU / KÄYTTÖOHJEET / BRUKSANVISNING / BRUGSANVISNING / INSTRUCȚIUNI DE ASAMBLARE /
NAVODILA ZA SESTAVLJANJE / NÁVOD NA MONTÁŽ / ÖSSZESZERELÉSI ÚTMUTATÓ / NÁVOD K MONTÁŽI / UPUTE ZA INSTALACIJU /
ΟΔΗΓΙΕΣ ΣΥΝΑΡΜΟΛΟΓΗΣΗΣ / SURINKIMO INSTRUKCIJOS / MONTĀŽAS INSTRUKCIJAS

Ext.

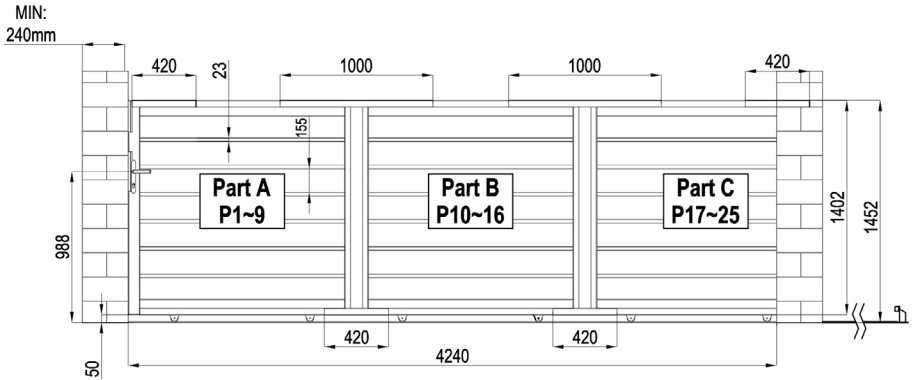

Int.

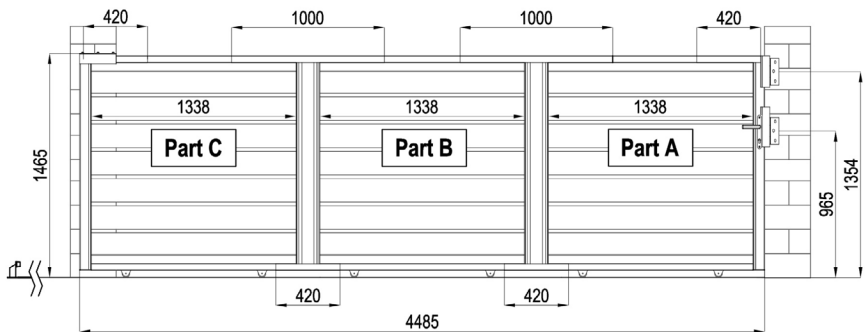

Part A.

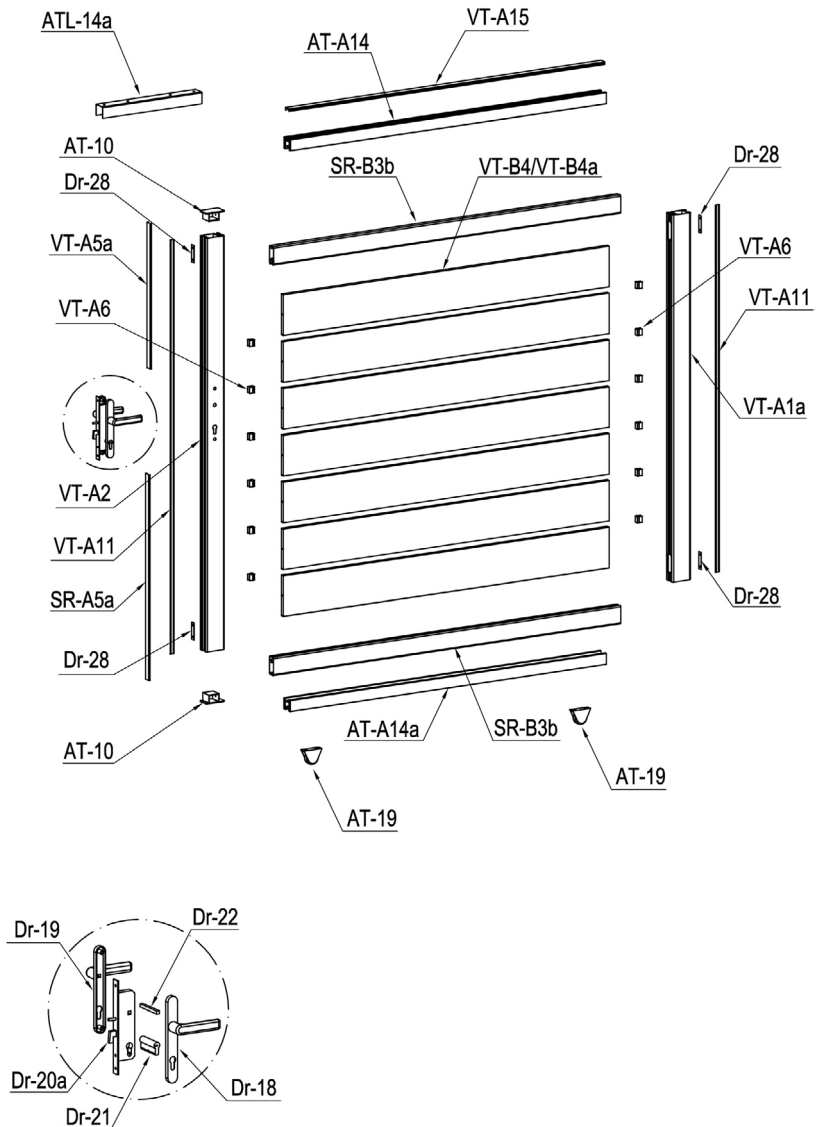

Part B.

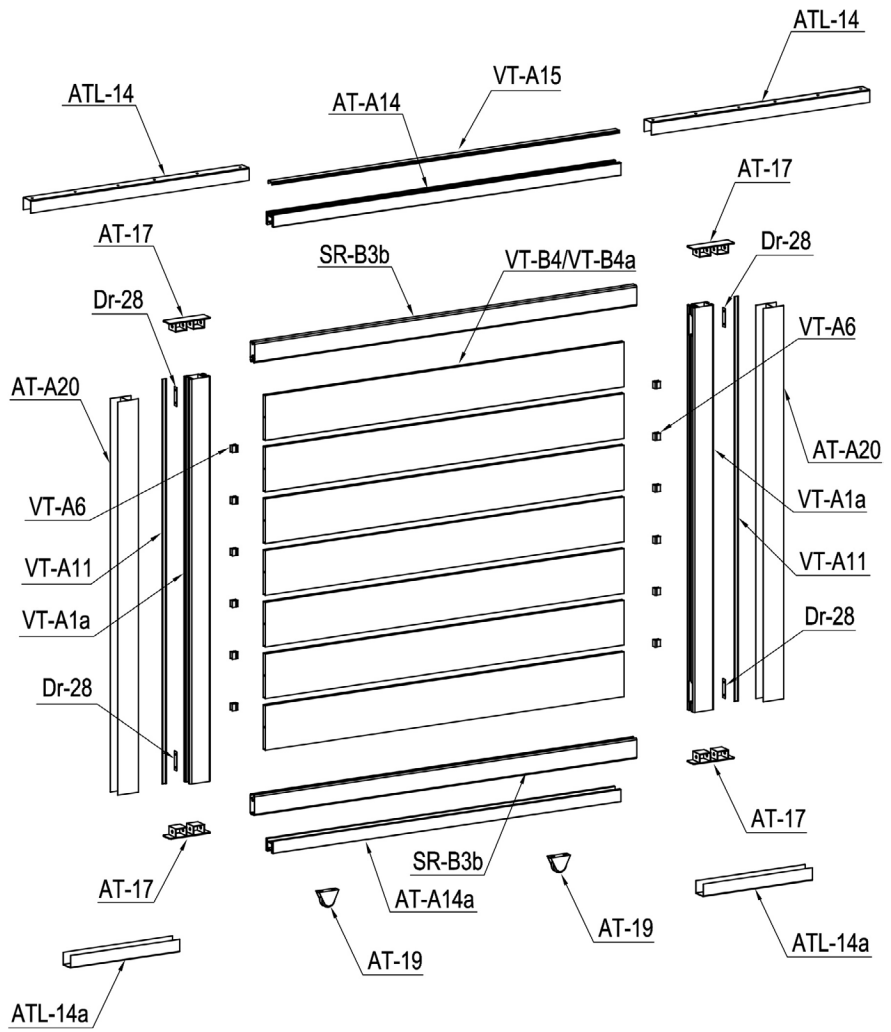



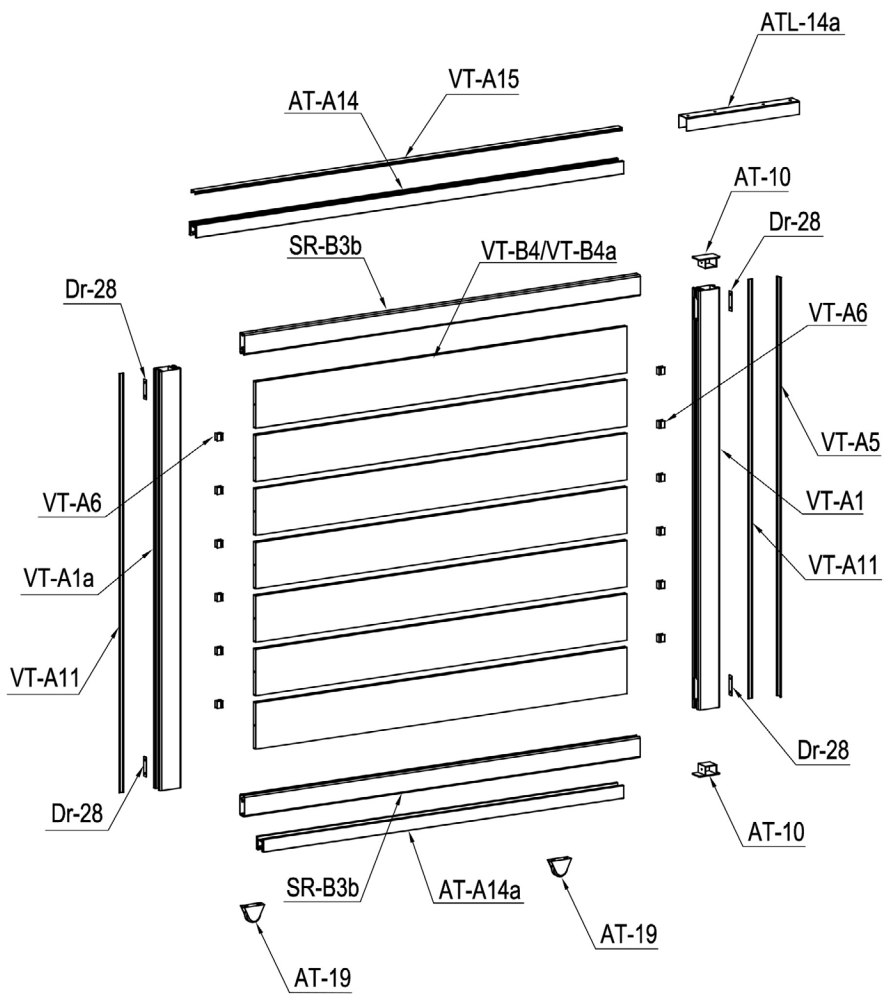

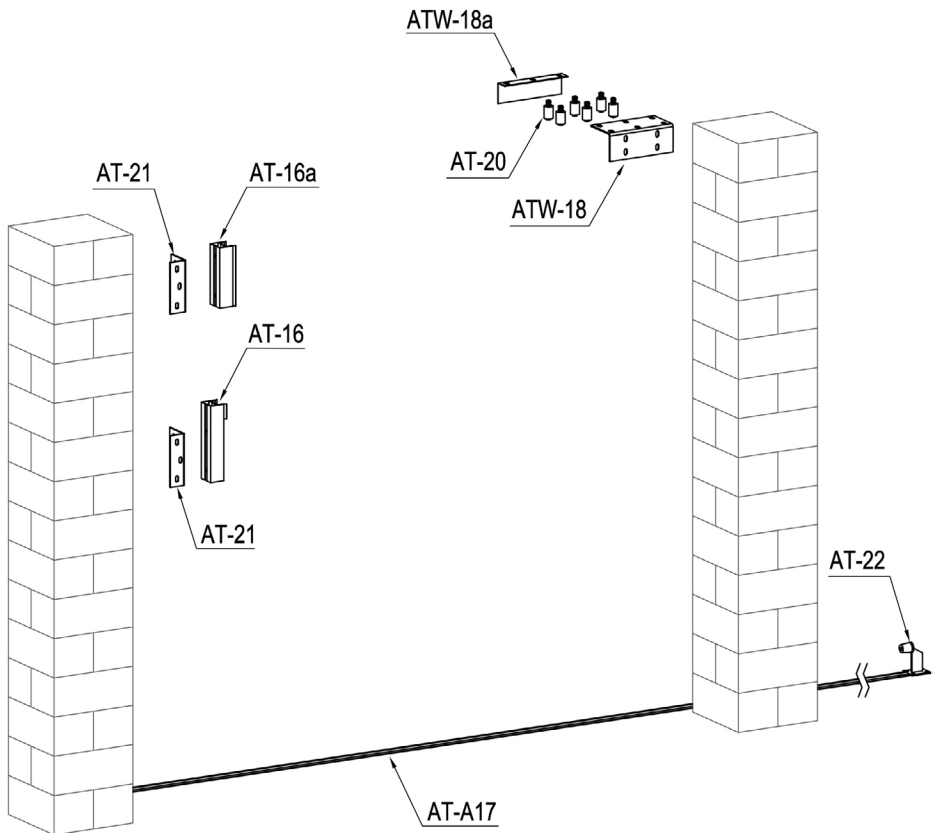



































Part C.







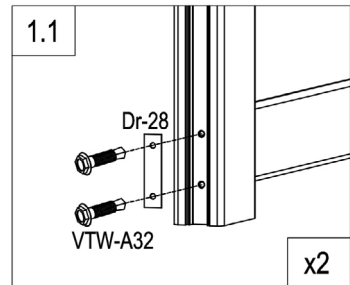
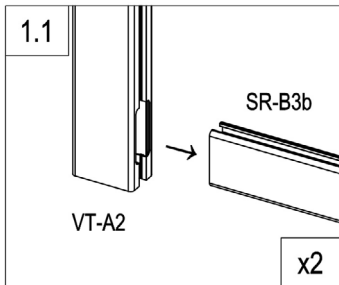
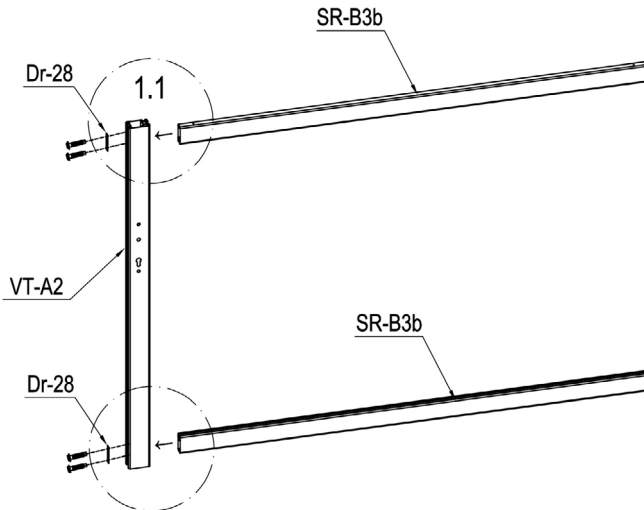

PART LIST

IMAGE	NO.	L.(mm)	QTY	IMAGE	NO.	L.(mm)	QTY
	VT-A1a	1395	4		Dr-21		1
	VT-A1	1395	1		Dr-22		1
	VT-A2	1395	1		Dr-25		1
	SR-B3b	1471	6		Dr-25a		2
	VT-B4	1380	18		Dr-27		2
	VT-B4a	1380	3		ATW-18		1
	VT-A5	1395	1		ATW-18a		1
	VT-A5a	372.5	1		AT-19		6
	SR-A5a	782	1		AT-20		6
	VT-A11	1395	6		AT-21		2
	VT-A6	23	36		AT-22		1
	AT-A20	1315	2		Dr-28		12
	AT-A14	1338	3		ATW-22J		10
	AT-A14a	1338	3		VTW-A30	ST4x10	4
	VT-A15	1337	3		VTW-A31	M8x60	14
	AT-16	260	1		VTW-A32	ST5.5x38	42
	AT-16a	205	1		VTW-A33	M8x130	4
	AT-A17	1212	7		VTW-A34	ST4.8x38	114
	ATL-14	1000	2		VTW-A36	M6x20	4
	ATL-14a	420	4		VTW-A37	M8x20	12
	AT-17		4		VTW-A38	ST4x25	56
	AT-10		4				
	Dr-18		1				
	Dr-19		1				
	Dr-20a		1				

Part A.



	VT-A2	1
	SR-B3b	2
	Dr-28	2
	VTW-A32	4

Part A.

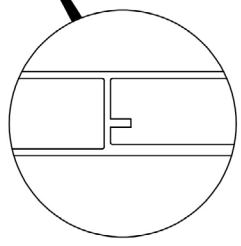
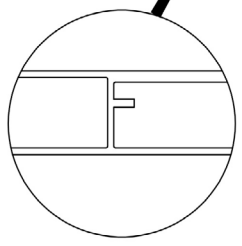
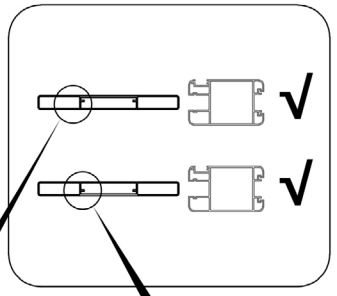
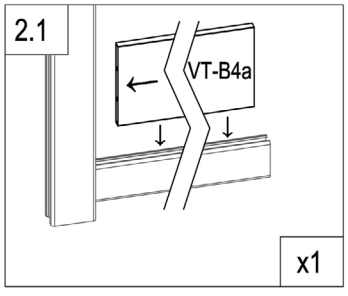
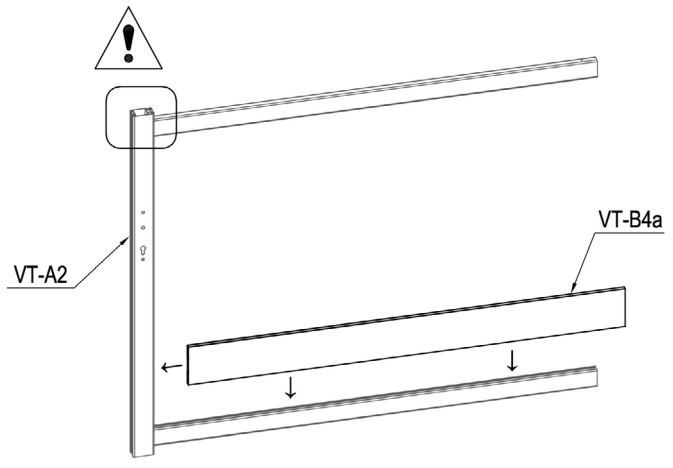

	VT-B4a	1
---	--------	---

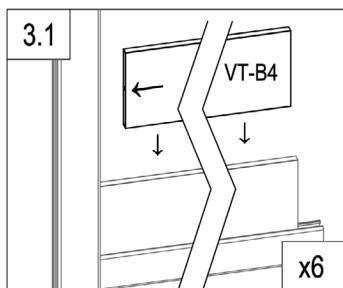
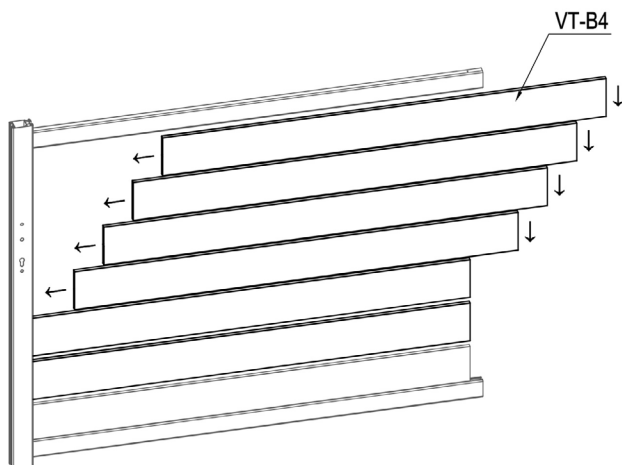

Part A.

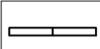

	VT-B4	6
---	-------	---

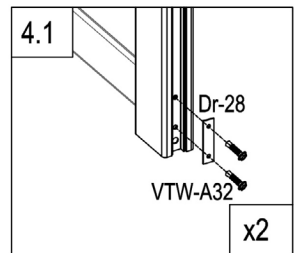
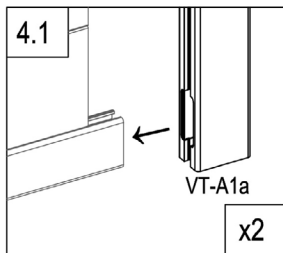
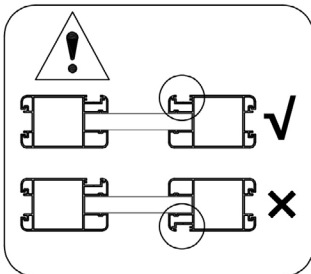
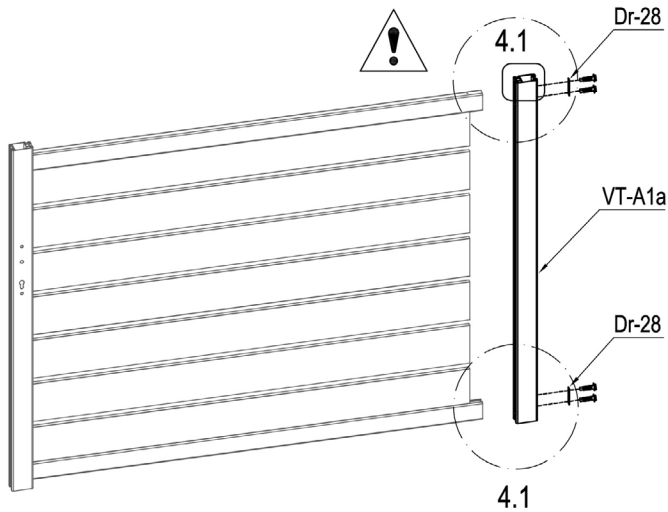
Part A.



	VT-A1a	1
	Dr-28	2
	VTW-A32	4

Part A.

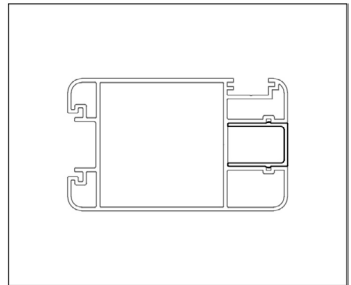
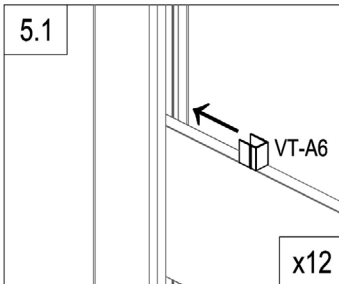
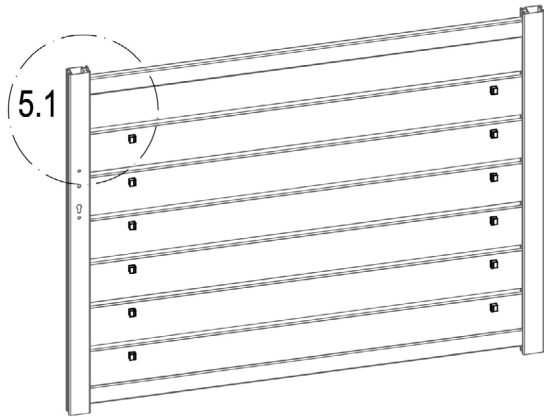

	VT-A6	12
--	-------	----

Part A.

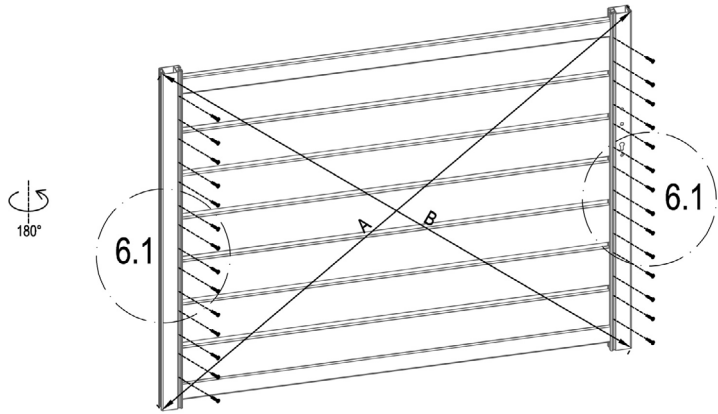

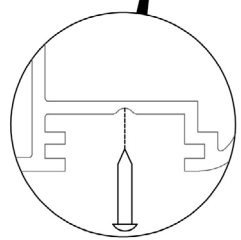
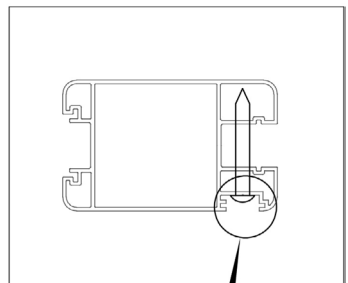
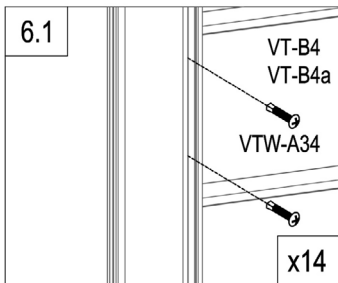

A=B

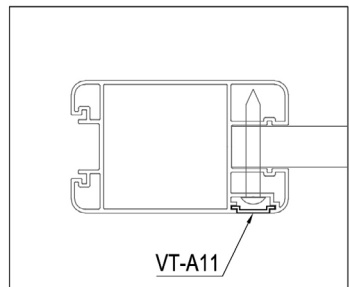
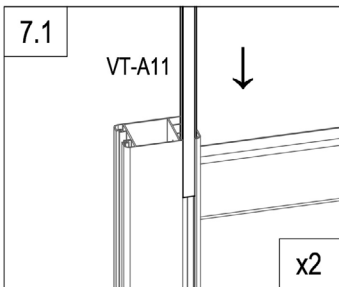
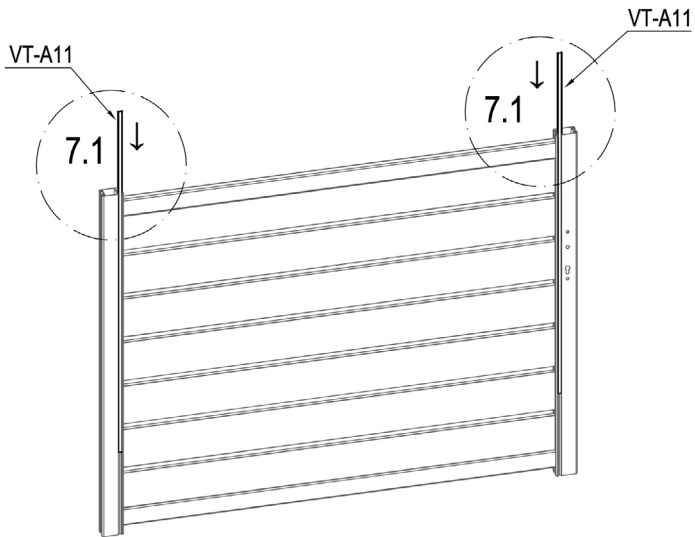

	VTW-A34	28
---	---------	----

Part A.



	VT-A11	2
---	--------	---

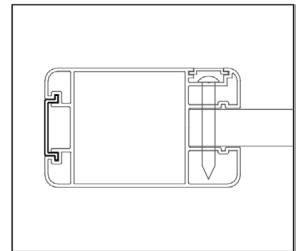
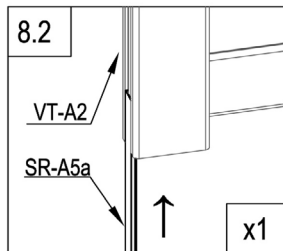
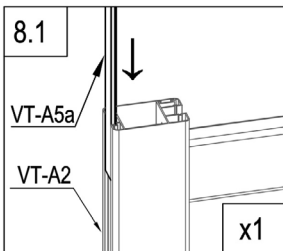
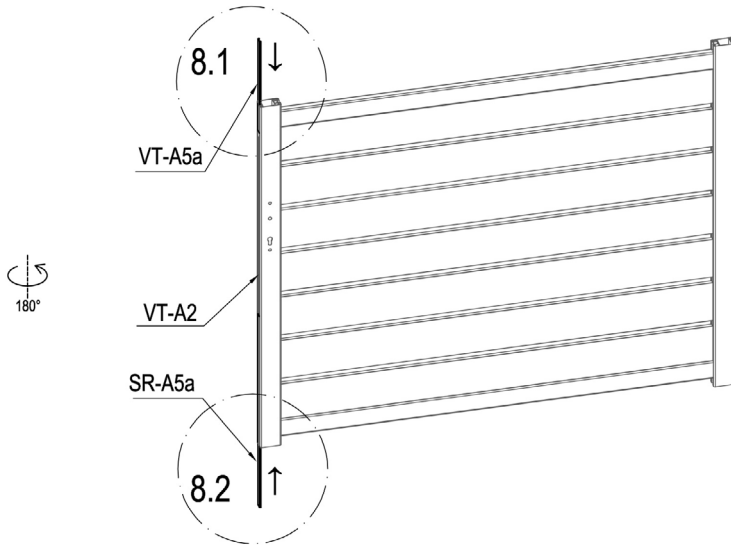

Part A.



	VT-A5a	1
	SR-A5a	1

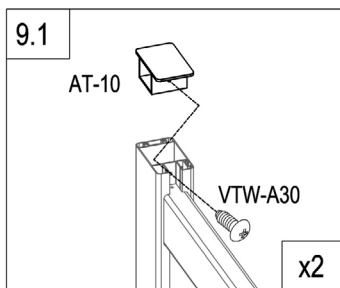
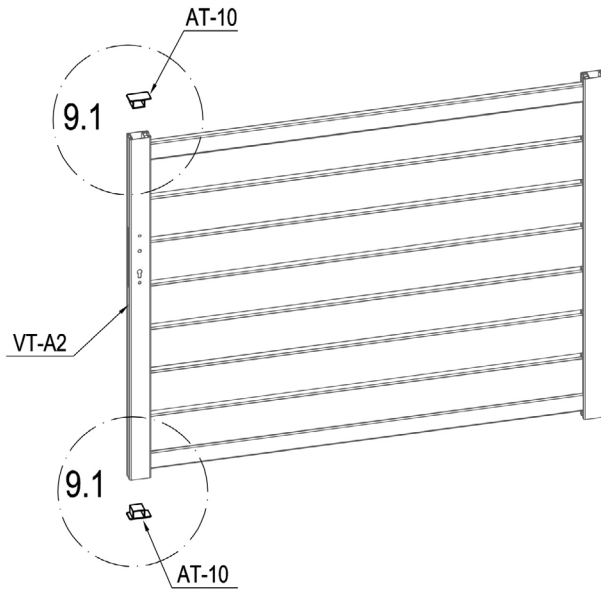



Part A.

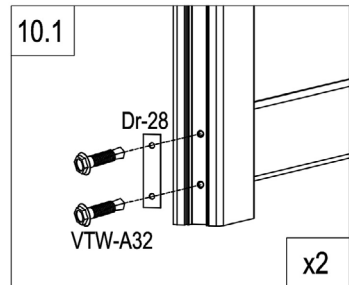
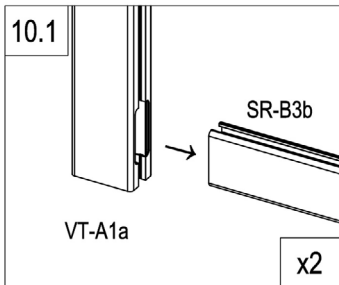
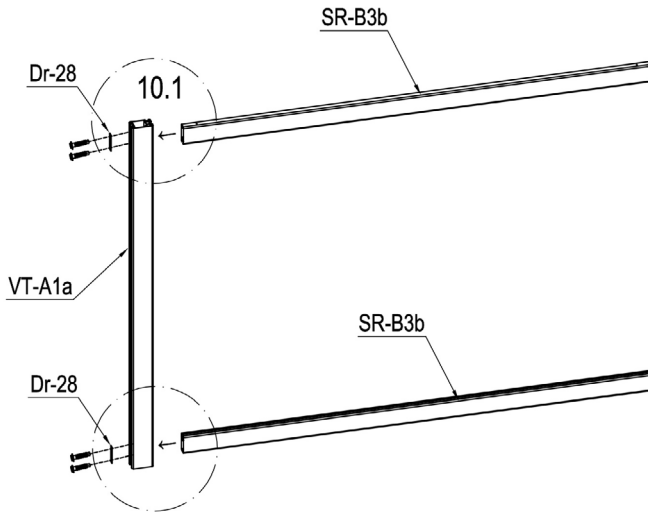

	AT-10	2
	VTW-A30	2

Part B.



	VT-A1a	1
	SR-B3b	2
	Dr-28	2
	VTW-A32	4

Part B.

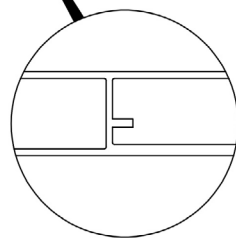
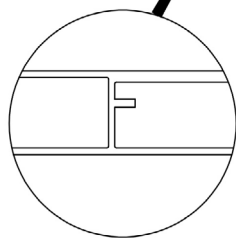
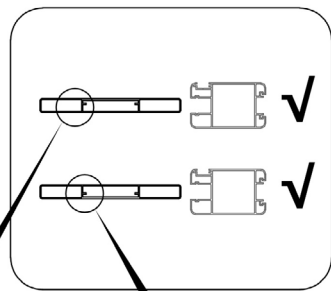
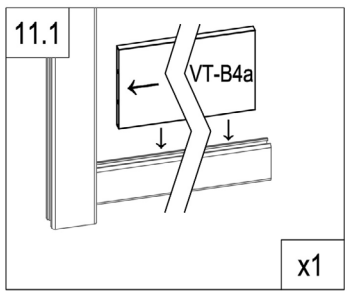
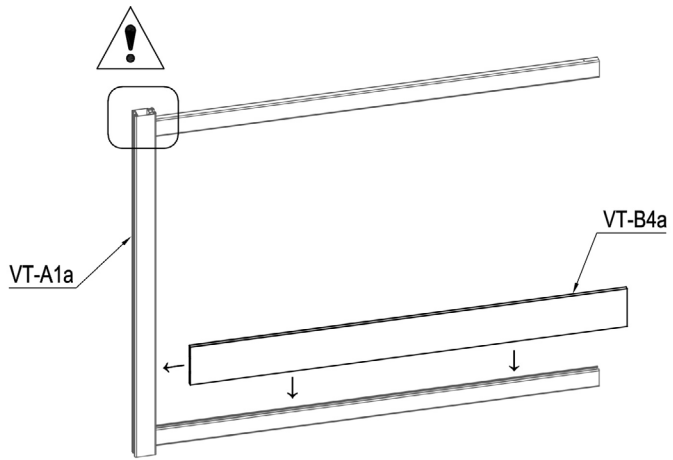

	VT-B4a	1
---	--------	---

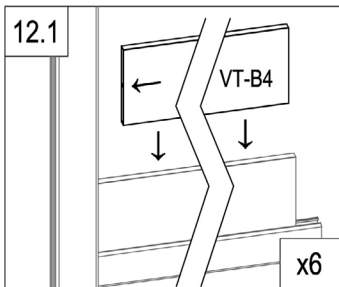
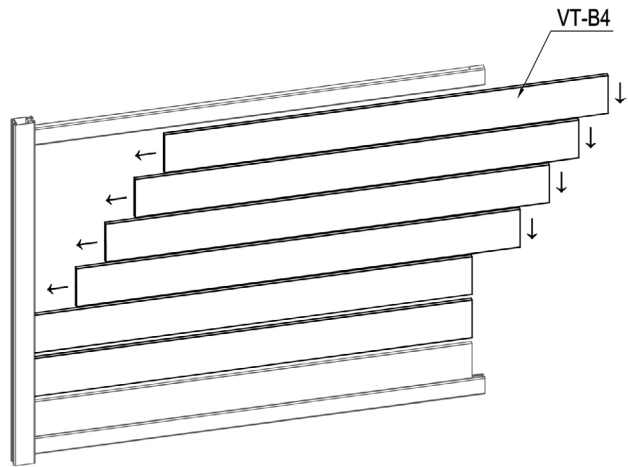

Part B.

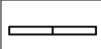

	VT-B4	6
---	-------	---

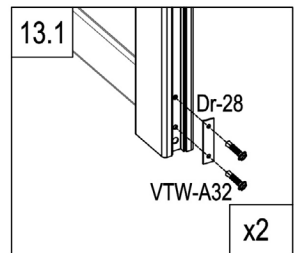
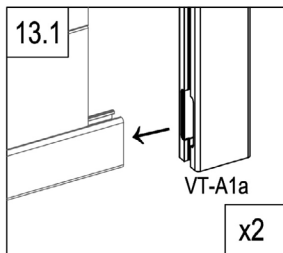
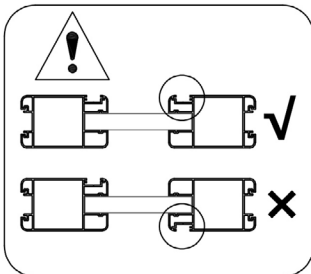
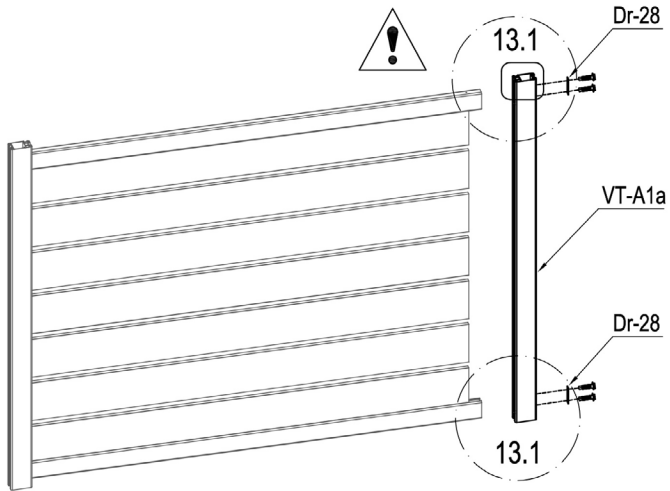
Part B.



	VT-A1a	1
	Dr-28	2
	VTW-A32	4

Part B.

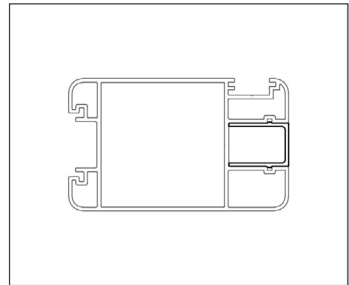
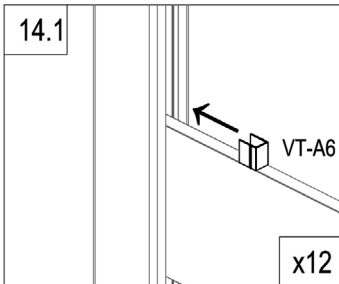
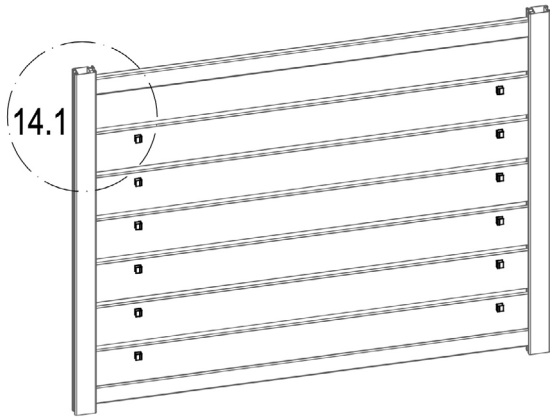

	VT-A6	12
---	-------	----

Part B.

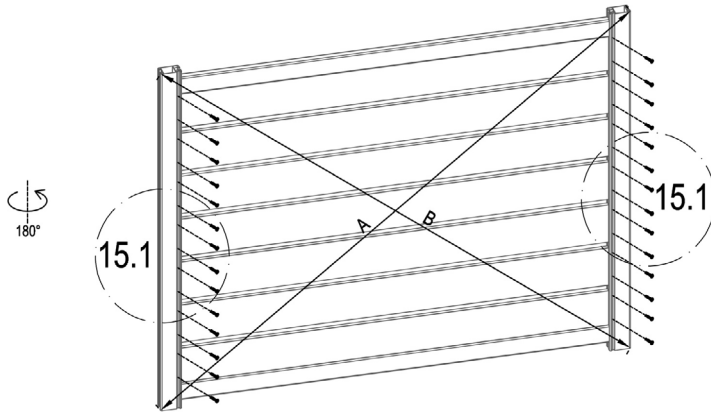

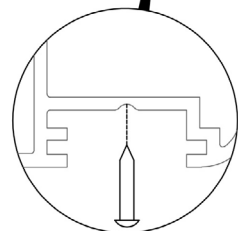
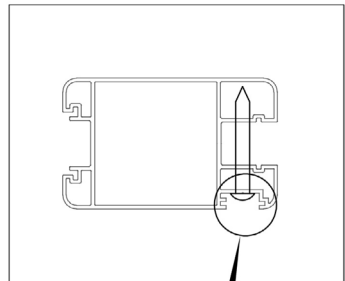
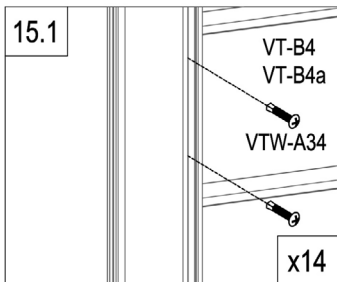

A=B



	VTW-A34	28
---	---------	----

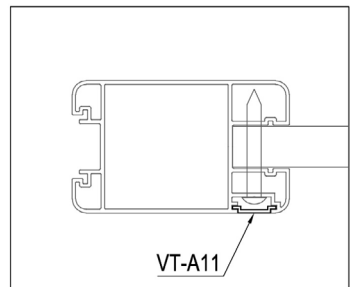
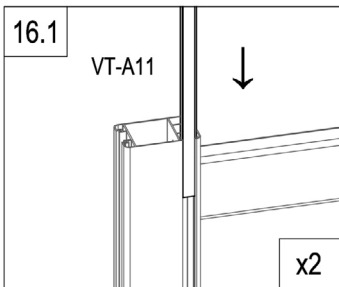
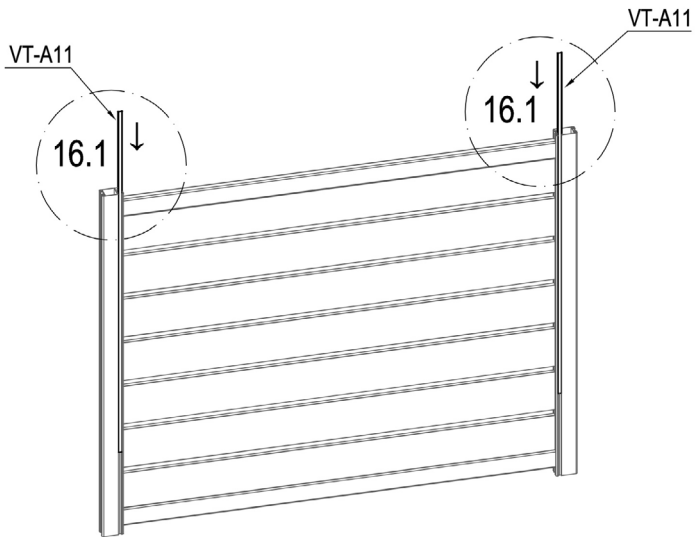



Part B.

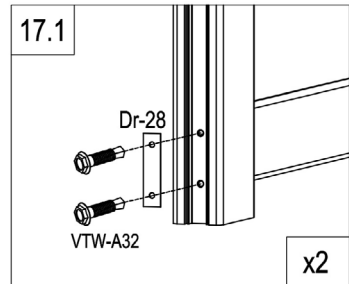
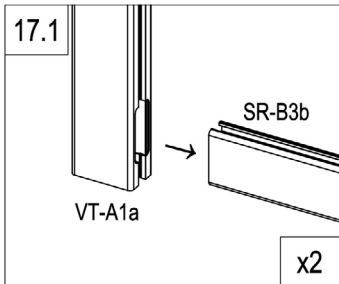
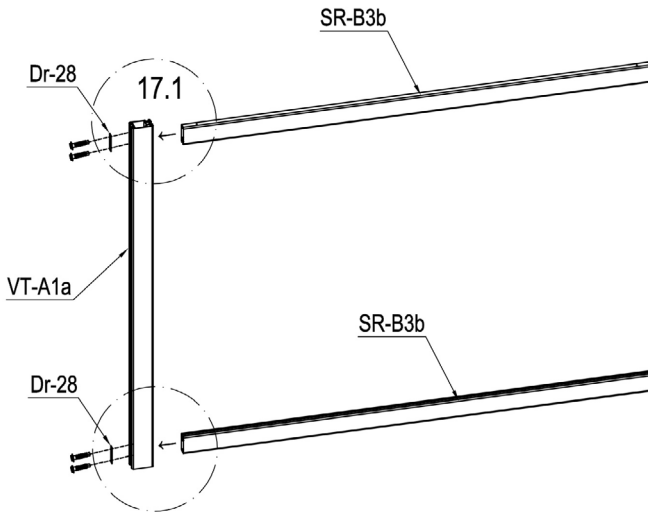

	VT-A11	2
---	--------	---

Part C.



	VT-A1a	1
	SR-B3b	2
	Dr-28	2
	VTW-A32	4

Part C.

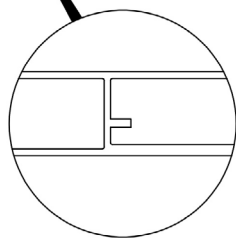
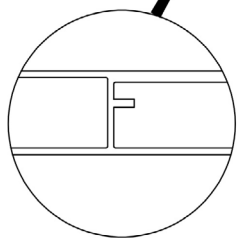
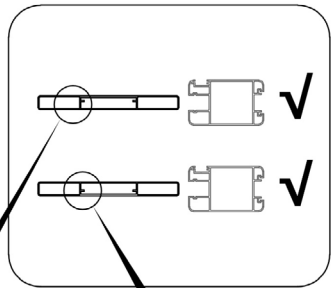
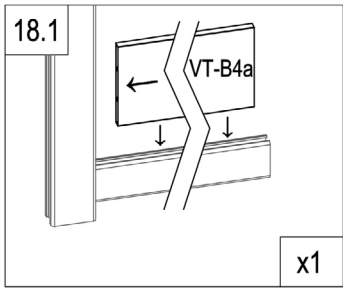
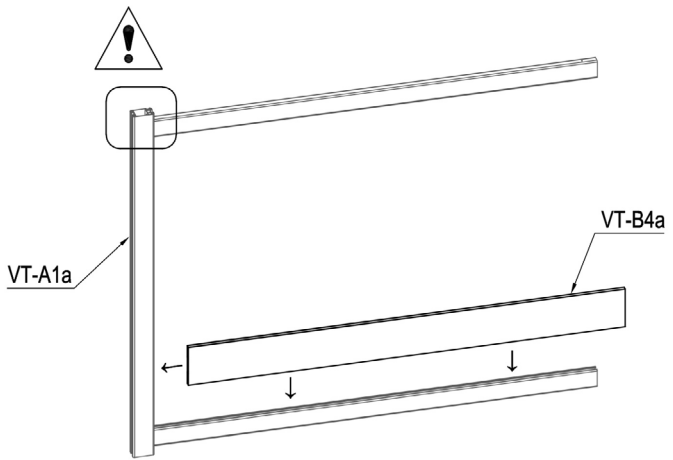

	VT-B4a	1
---	--------	---

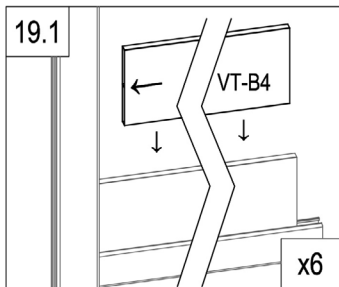
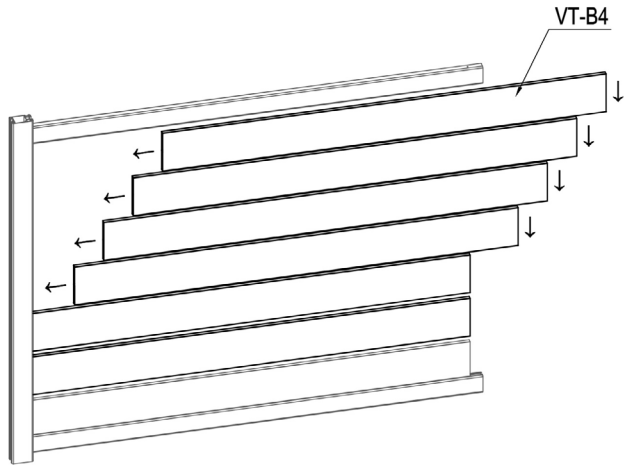

Part C.

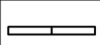

	VT-B4	6
---	-------	---

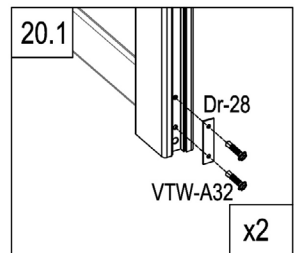
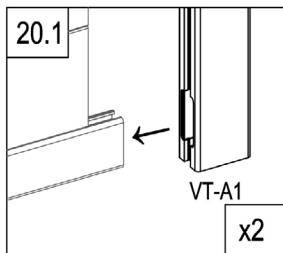
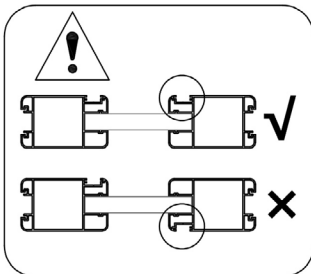
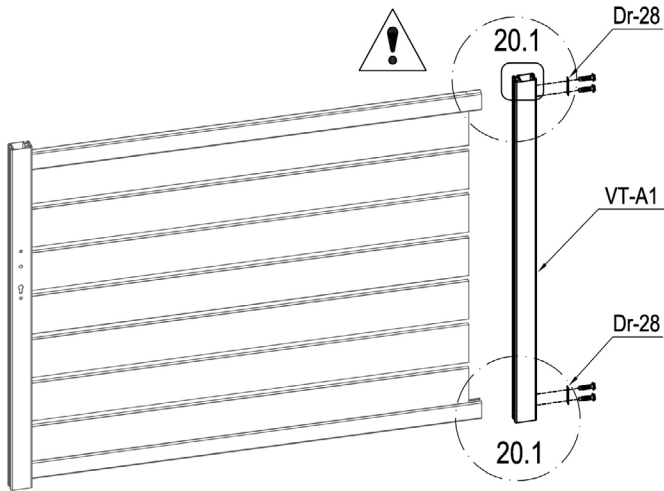
Part C.



	VT-A1	1
	Dr-28	2
	VTW-A32	4

Part C.

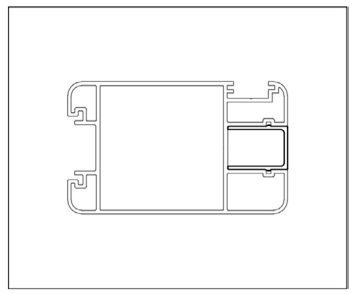
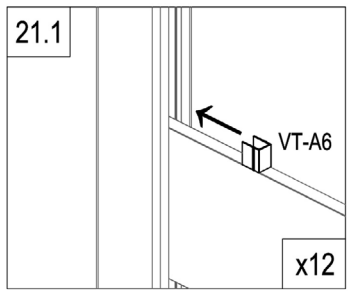
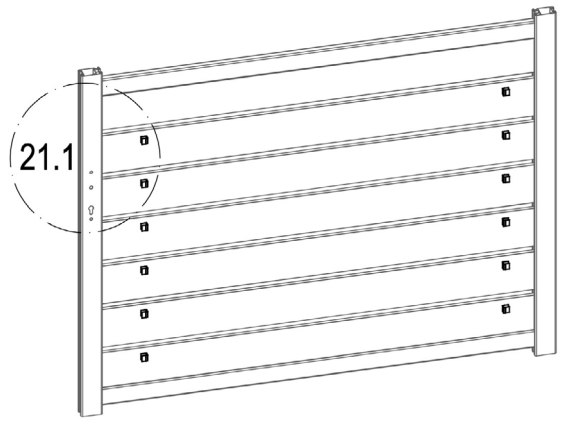

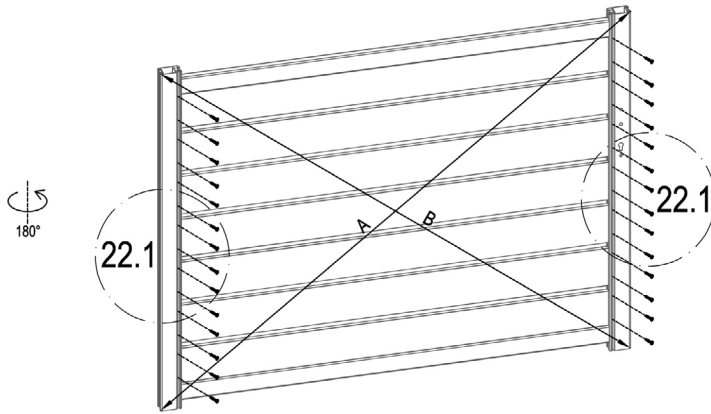

	VT-A6	12
---	-------	----

Part C.



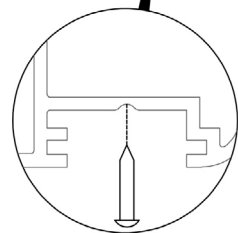
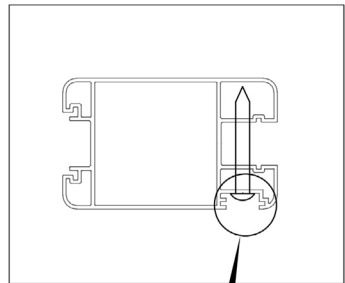
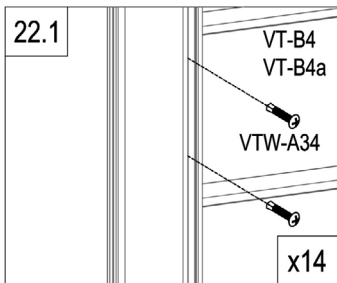

A=B

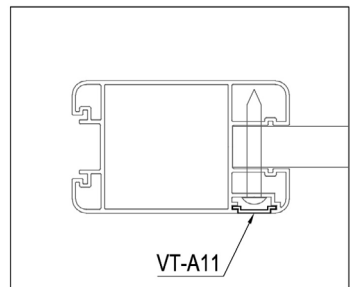
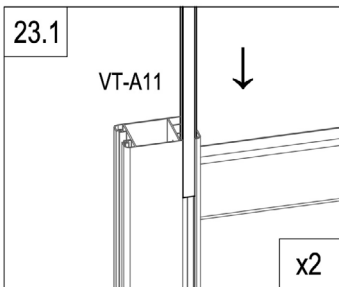
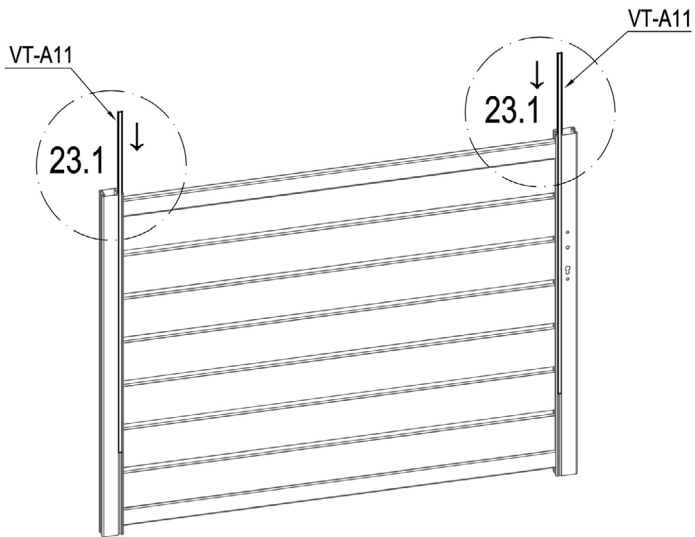

	VTW-A34	28
---	---------	----

Part C.



	VT-A11	2
---	--------	---

Part C.

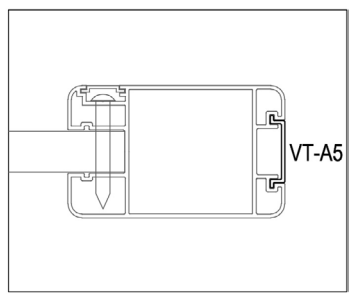
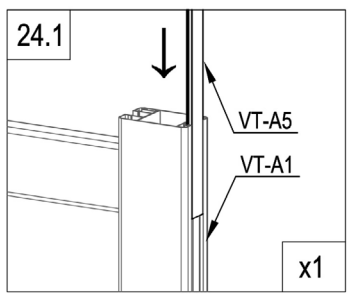
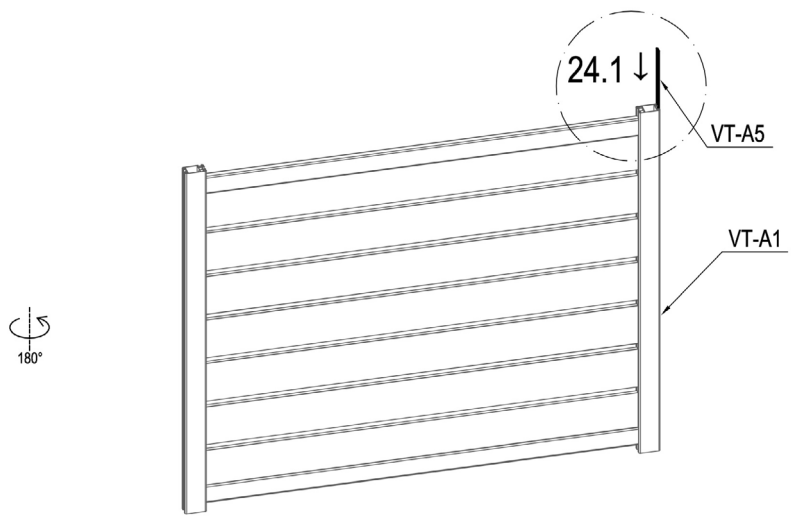



}	VT-A5	1
---	-------	---

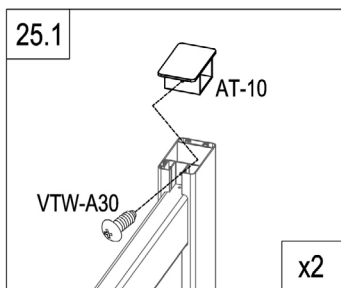
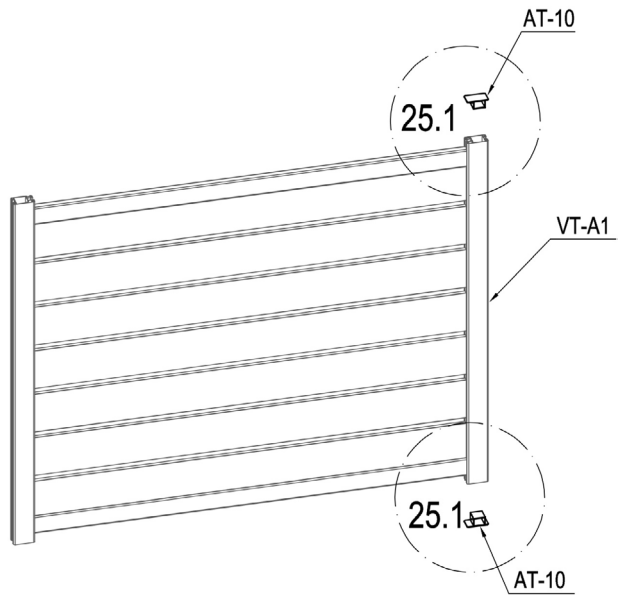

Part C.



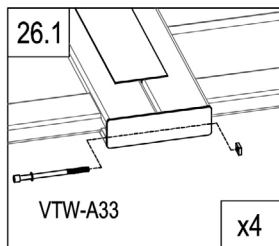
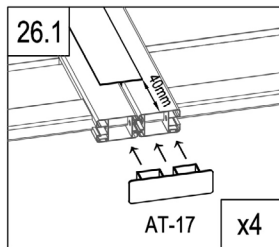
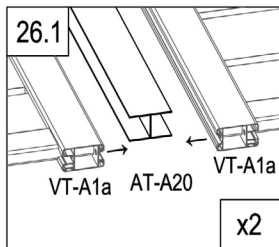
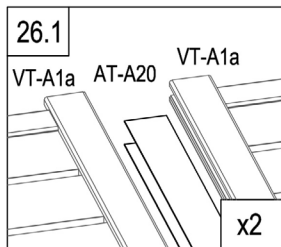
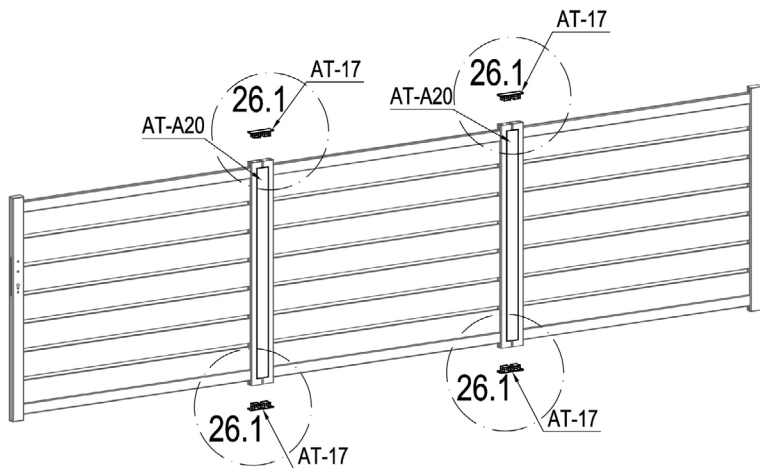

Part C.

	AT-10	2
	VTW-A30	2

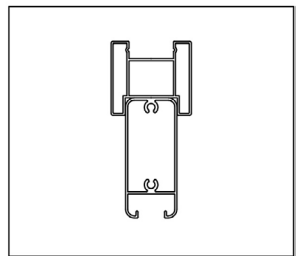
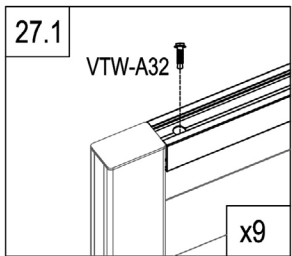
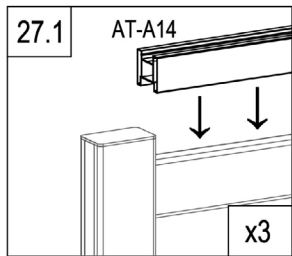
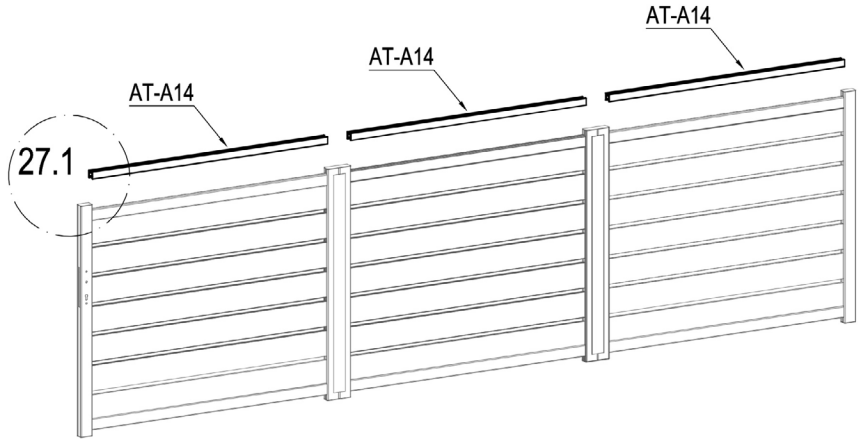

	AT-A20	2
	AT-17	4
	VTW-A33	4



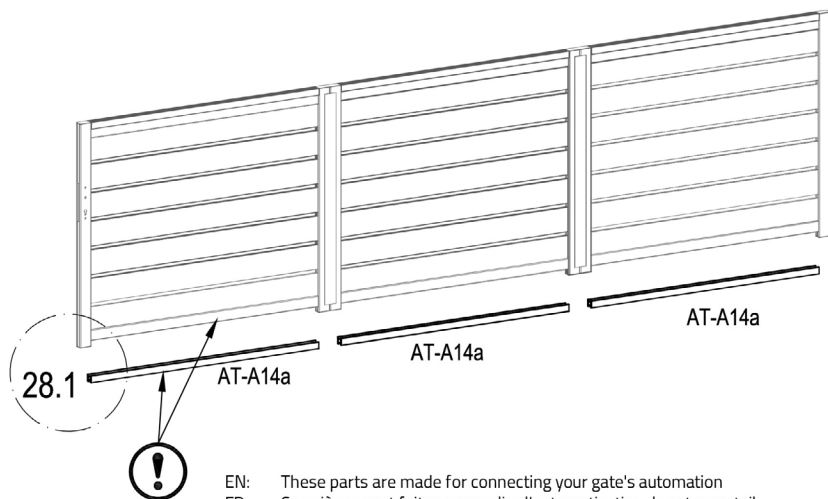

	AT-A14	3
	VTW-A32	18



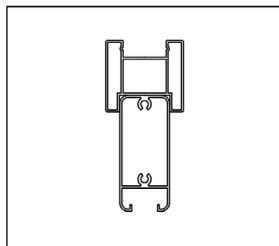
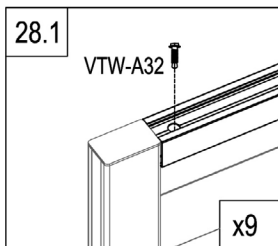
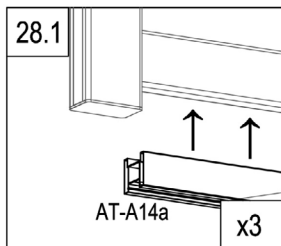

EN: These parts are made for connecting your gate's automation
 FR: Ces pièces sont faites pour relier l'automatisation de votre portail
 DE: Diese Teile sind für den Anschluss der Automatisierung Ihres Tores vorgesehen
 ES: Estas piezas están hechas para conectar la automatización de su puerta
 PT: Estas peças são feitas para ligar a automatização do seu portão
 IT: Queste parti sono realizzate per collegare l'automazione del vostro cancello
 NL: Deze onderdelen zijn gemaakt voor het aansluiten van de automatisering van uw poort.
 PL: Te części są wykonane do podłączenia automatyki bramy.



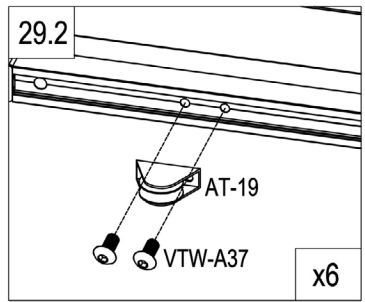
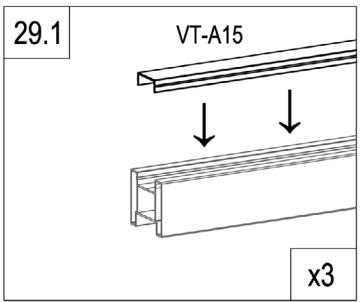
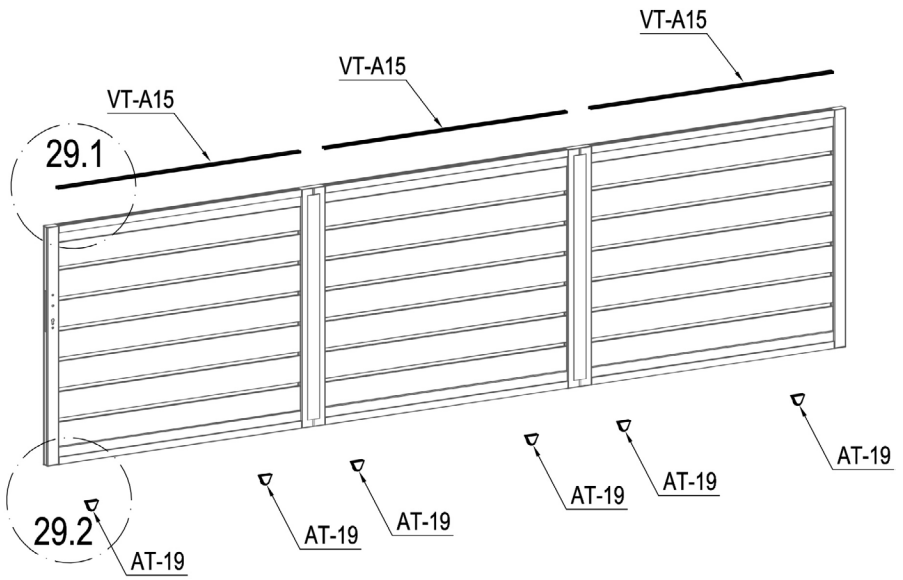

	AT-A14a	3
	VTW-A32	18

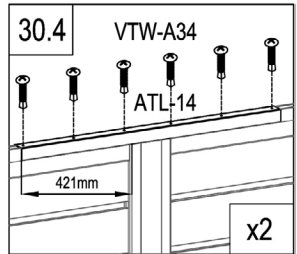
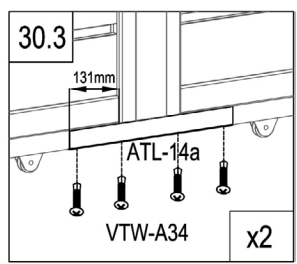
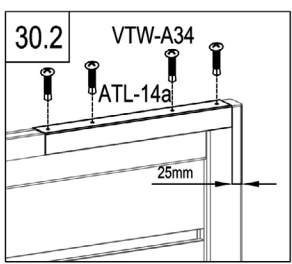
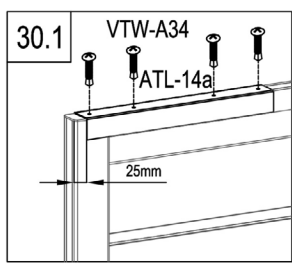
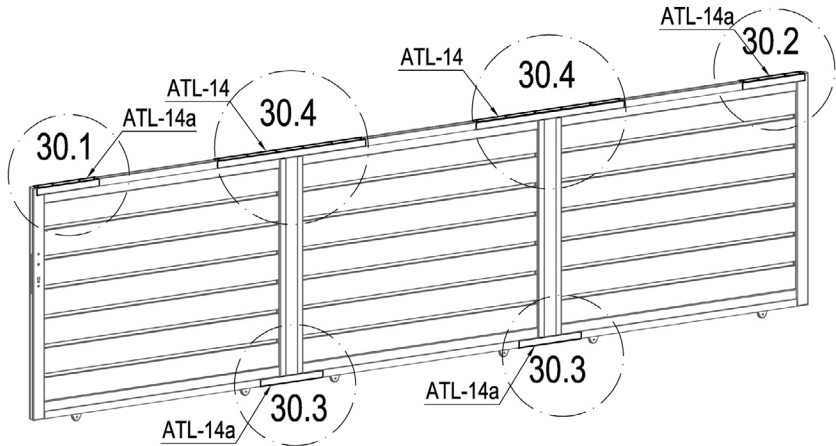

	VT-A15	3
	AT-19	6
	VTW-A37	12



	ATL-14	2
	ATL-14a	4
	VTW-A34	28

Ext.

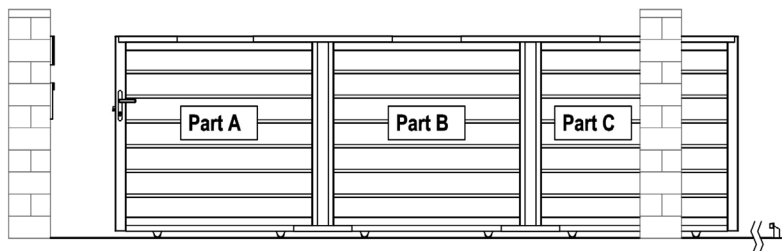

Int.

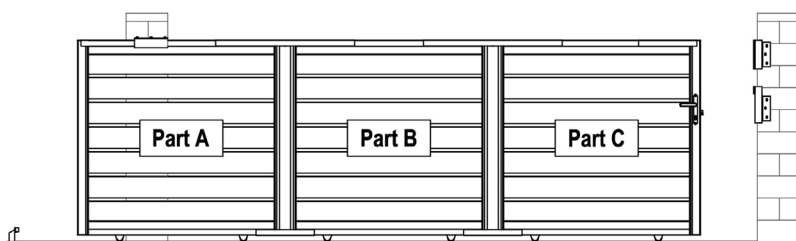

Ext.

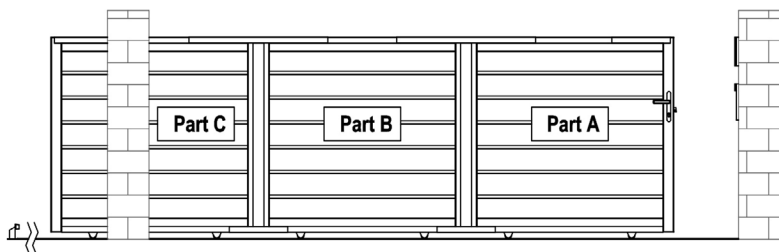

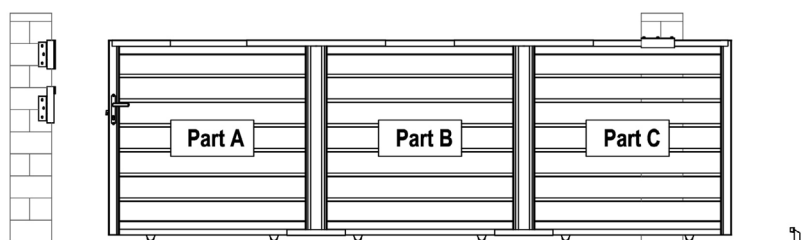

Int.

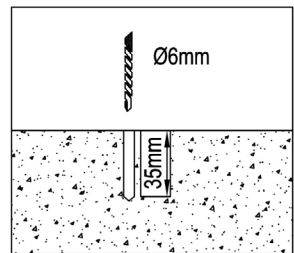
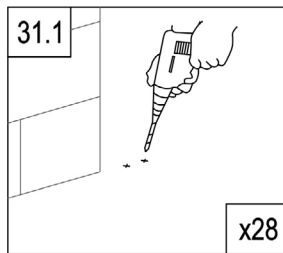
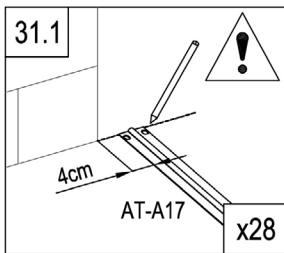
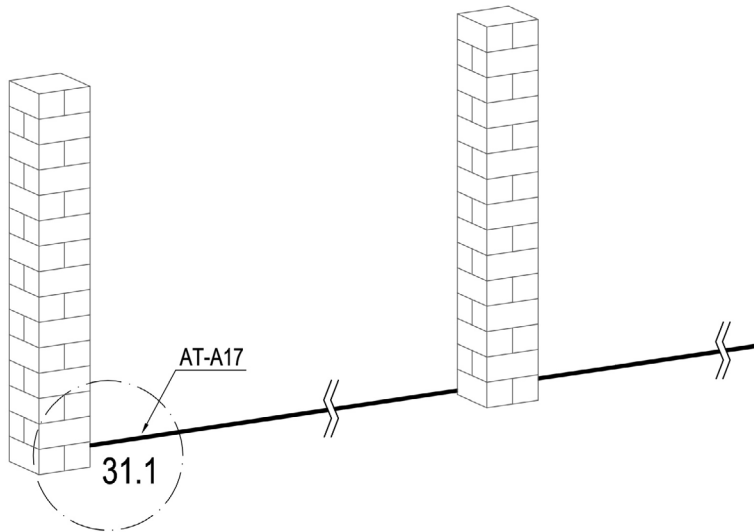

R

L



	AT-A17	7
	VTW-A38	56

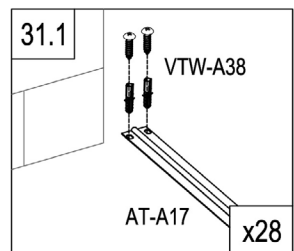

L

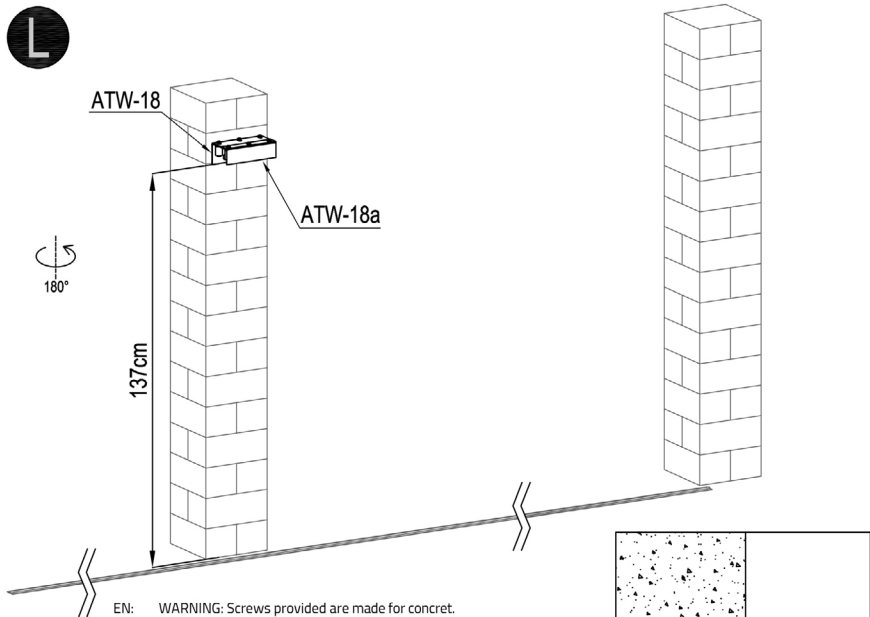

EN: WARNING: Screws provided are made for concret.
 FR: AVERTISSEMENT : Les vis fournies sont faites pour le béton.
 DE: WARNUNG: Die mitgelieferten Schrauben sind für Beton ausgelegt.
 ES: ADVERTENCIA: Los tornillos suministrados están hechos para el hormigón.
 IT: ATTENZIONE: Le viti fornite sono fatte per il calcestruzzo.
 NL: WAARSCHUWING: De bijgeleverde schroeven zijn gemaakt voor beton.
 PL: OSTRZEŻENIE: Dostarczone śruby są przeznaczone do betonu.
 PT: AVISO: Os parafusos fornecidos são feitos para betão.

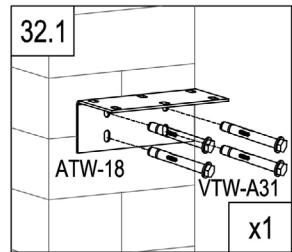
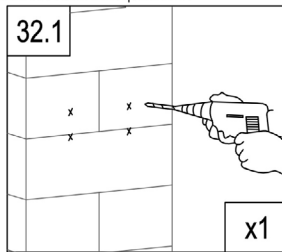
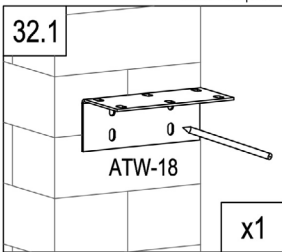
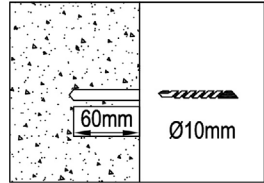

	ATW-18	1
	ATW-18a	1
	AT-20	6
	VTW-A31	4

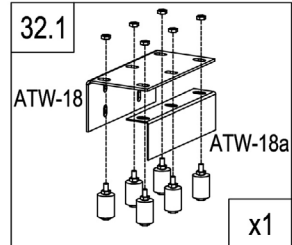
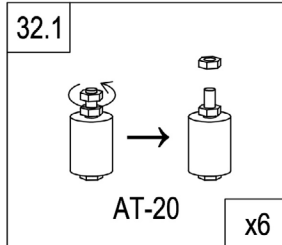

L

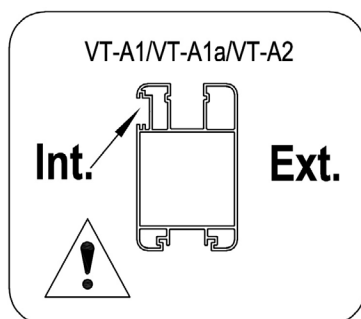
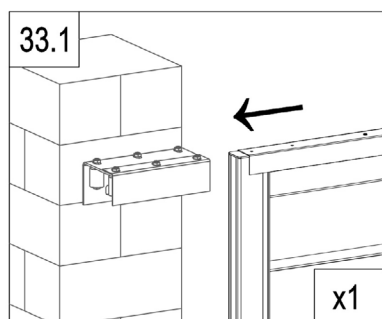
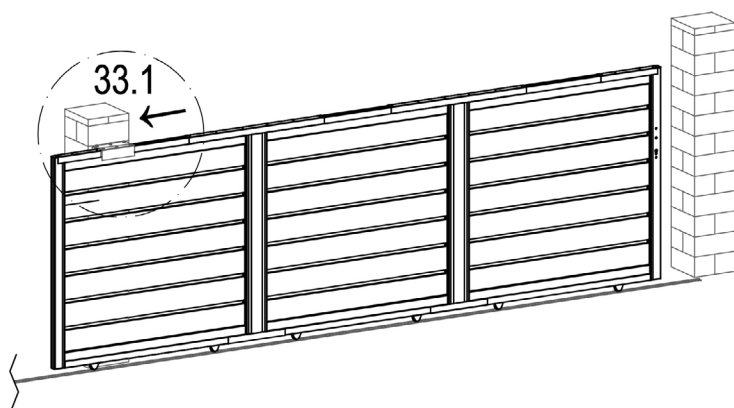

L

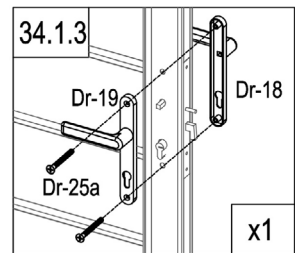
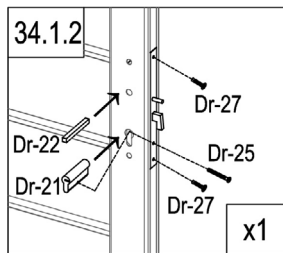
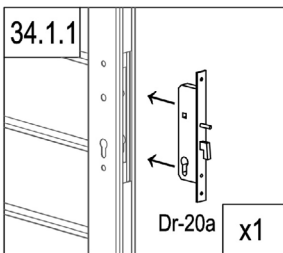
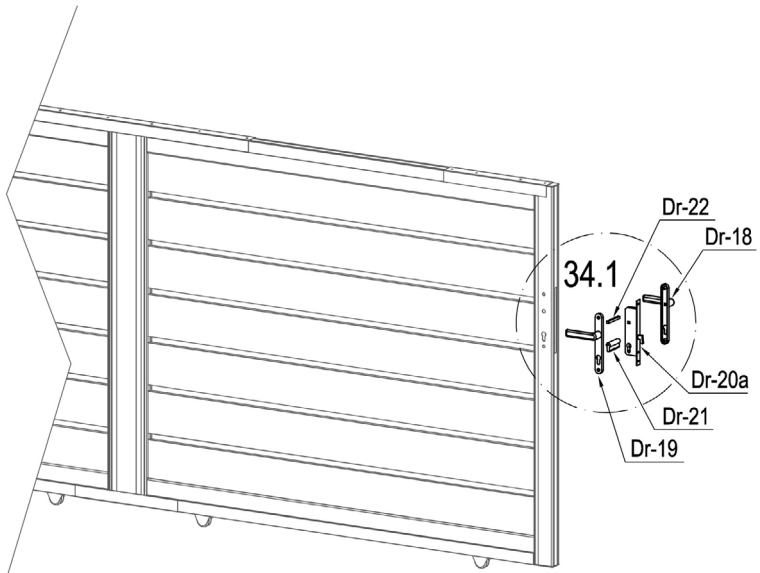

	Dr-20a	1
	Dr-21	1
	Dr-22	1
	Dr-25	1

	Dr-18	1
	Dr-19	1
	Dr-25a	2
	Dr-27	2



EN: WARNING: Screws provided are made for concret.
 FR: AVERTISSEMENT : Les vis fournies sont faites pour le béton.
 DE: WARNUNG: Die mitgelieferten Schrauben sind für Beton ausgelegt.
 ES: ADVERTENCIA: Los tornillos suministrados están hechos para el hormigón.
 IT: ATTENZIONE: Le viti fornite sono fatte per il calcestruzzo.
 NL: WAARSCHUWING: De bijgeleverde schroeven zijn gemaakt voor beton.
 PL: OSTRZEŻENIE: Dostarczone śruby są przeznaczone do betonu.
 PT: AVISO: Os parafusos fornecidos são feitos para betão.

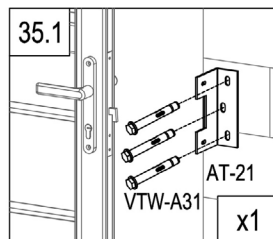
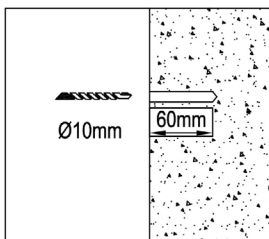
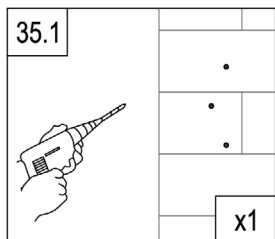
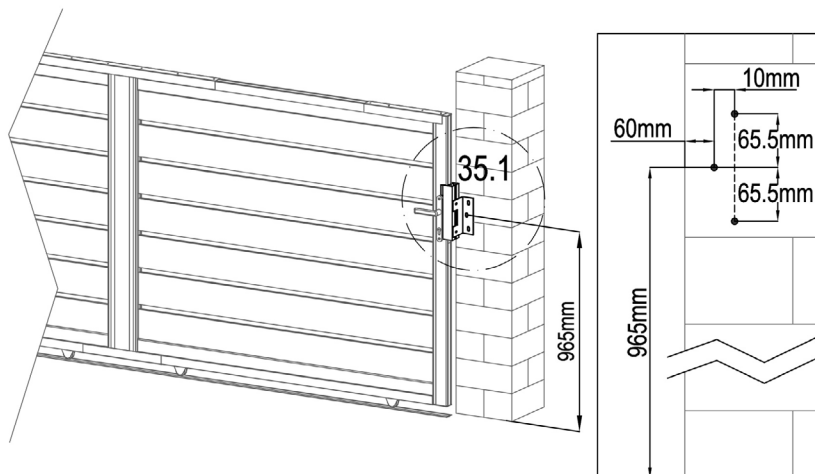

	AT-16	1
	AT-21	1
	VTW-A36	2
	VTW-A31	3
	ATW-22J	3

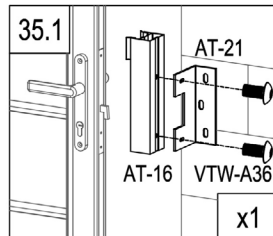
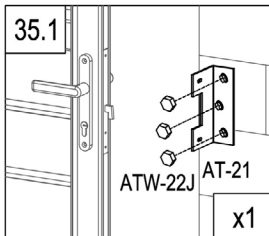

L

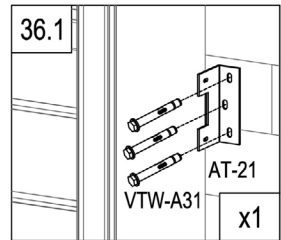
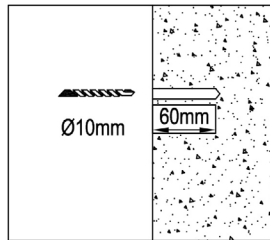
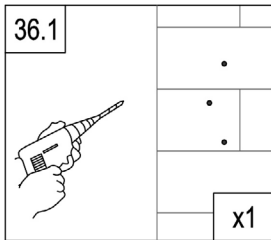
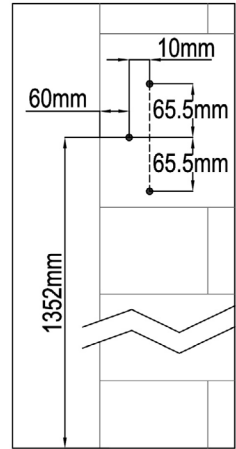
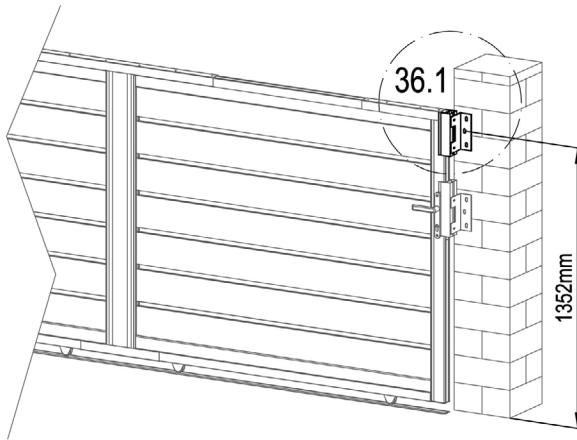

	AT-16a	1
	AT-21	1
	VTW-A36	2
	VTW-A31	3
	ATW-22J	3

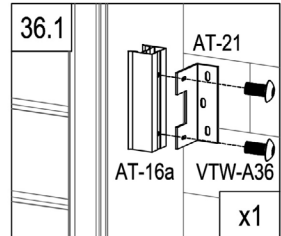
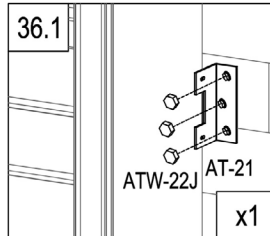

L

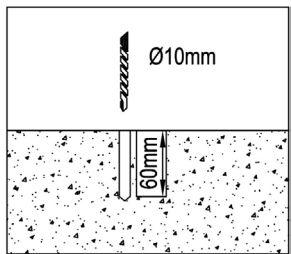
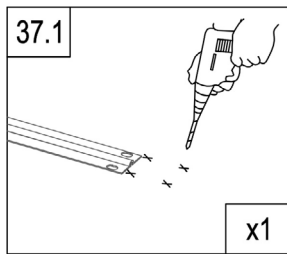
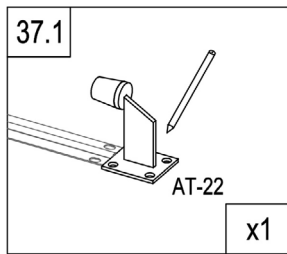
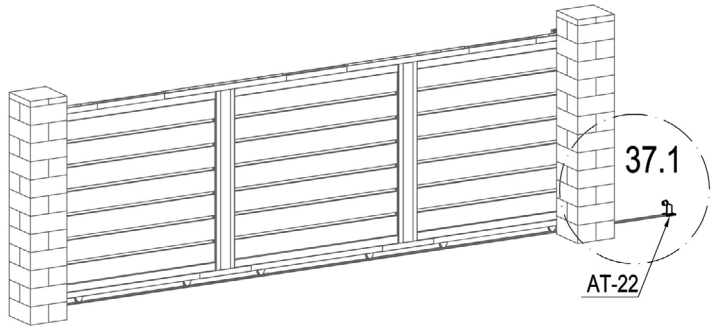

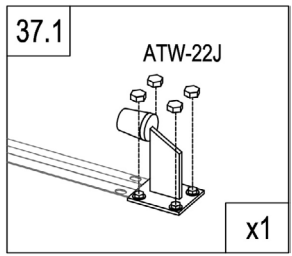
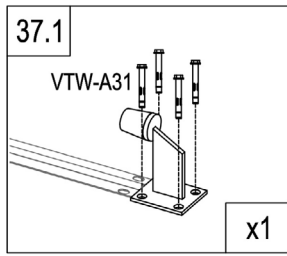

	AT-22	1
	VTW-A31	4
	ATW-22J	4

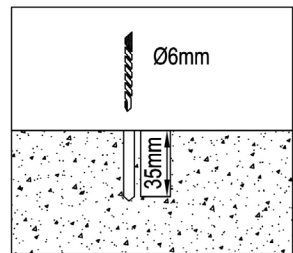
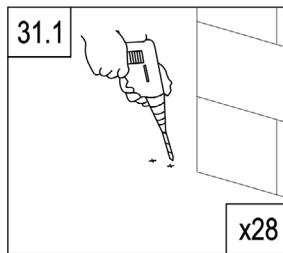
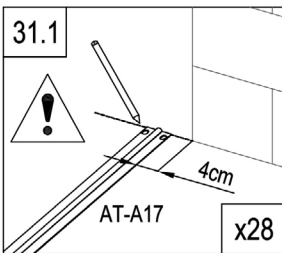
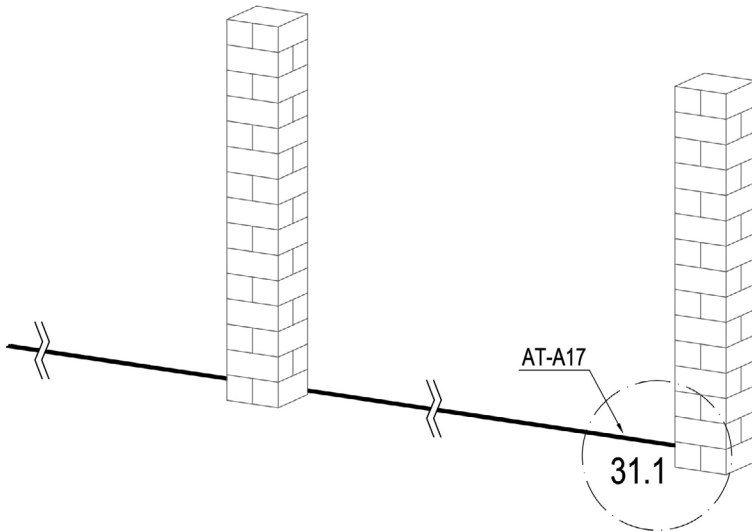

R



	AT-A17	6
	VTW-A38	56

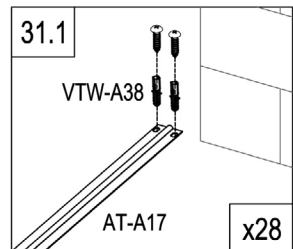

R

180°

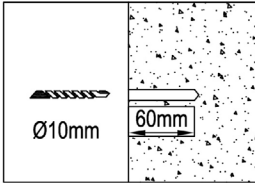
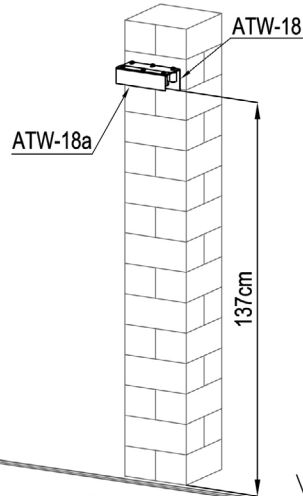

EN: WARNING: Screws provided are made for concret.
 FR: AVERTISSEMENT : Les vis fournies sont faites pour le béton.
 DE: WARNUNG: Die mitgelieferten Schrauben sind für Beton ausgelegt.
 ES: ADVERTENCIA: Los tornillos suministrados están hechos para el hormigón.
 IT: ATTENZIONE: Le viti fornite sono fatte per il calcestruzzo.
 NL: WAARSCHUWING: De bijgeleverde schroeven zijn gemaakt voor beton.
 PL: OSTRZEŻENIE: Dostarczone śruby są przeznaczone do betonu.
 PT: AVISO: Os parafusos fornecidos são feitos para betão.

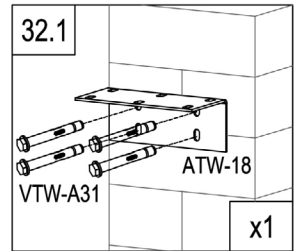
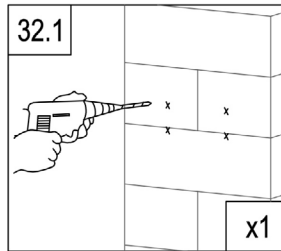
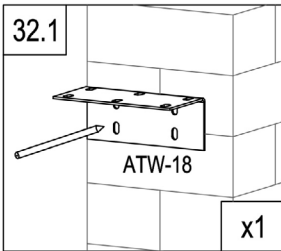

	ATW-18	1
	ATW-18a	1
	AT-20	6
	VTW-A31	4

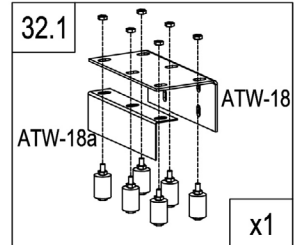
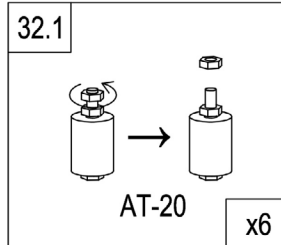

R

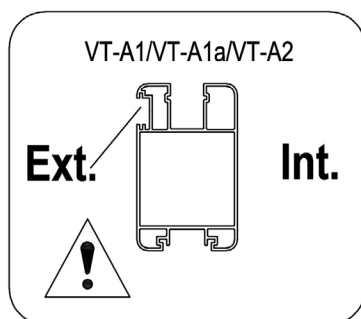
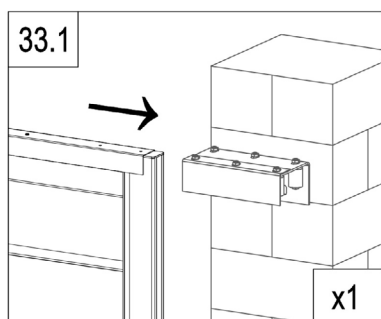
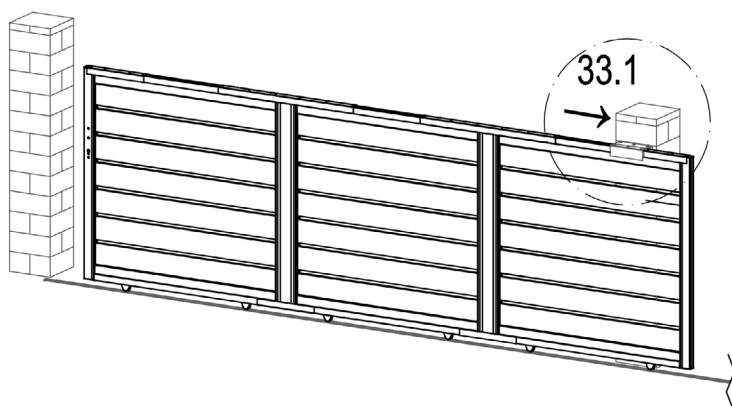

R

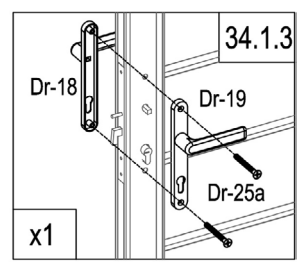
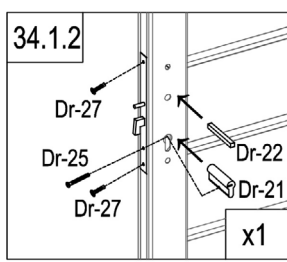
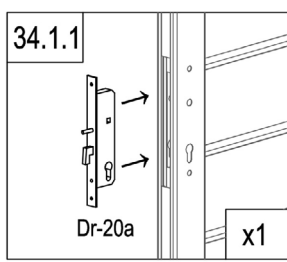
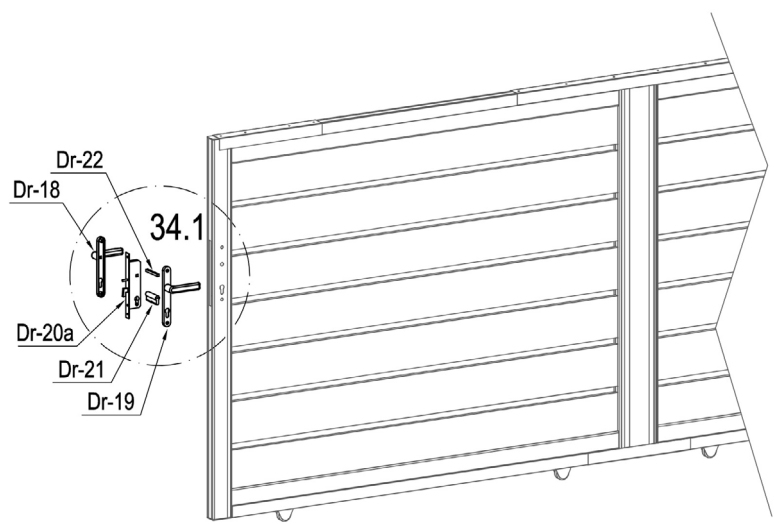

	Dr-20a	1
	Dr-21	1
	Dr-22	1
	Dr-25	1

	Dr-18	1
	Dr-19	1
	Dr-25a	2
	Dr-27	2



EN: WARNING: Screws provided are made for concrete.
 FR: AVERTISSEMENT : Les vis fournies sont faites pour le béton.
 DE: WARNUNG: Die mitgelieferten Schrauben sind für Beton ausgelegt.
 ES: ADVERTENCIA: Los tornillos suministrados están hechos para el hormigón.
 IT: ATTENZIONE: Le viti fornite sono fatte per il calcestruzzo.
 NL: WAARSCHUWING: De bijgeleverde schroeven zijn gemaakt voor beton.
 PL: OSTRZEŻENIE: Dostarczone śruby są przeznaczone do betonu.
 PT: AVISO: Os parafusos fornecidos são feitos para betão.

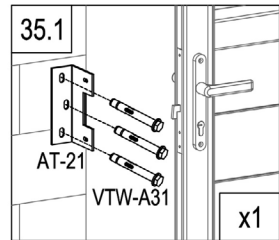
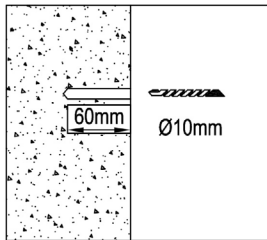
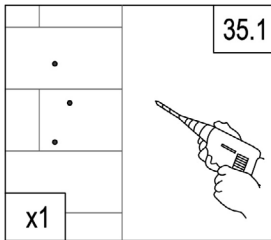
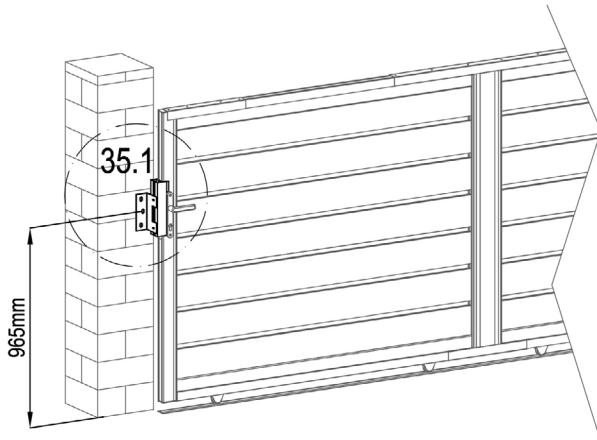
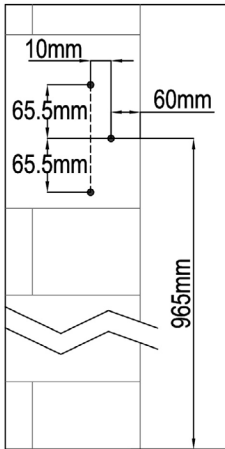

	AT-16	1
	AT-21	1
	VTW-A36	2
	VTW-A31	3
	ATW-22J	3

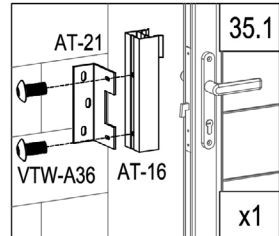
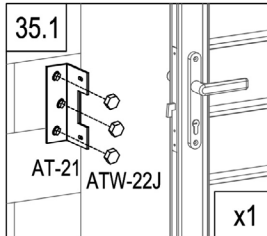

R

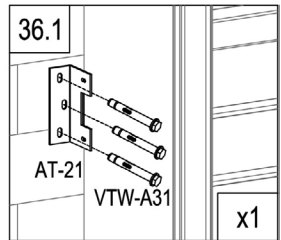
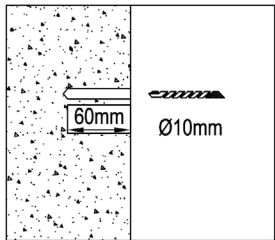
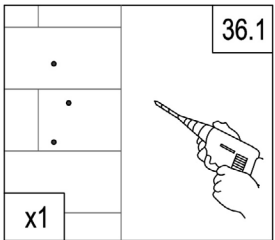
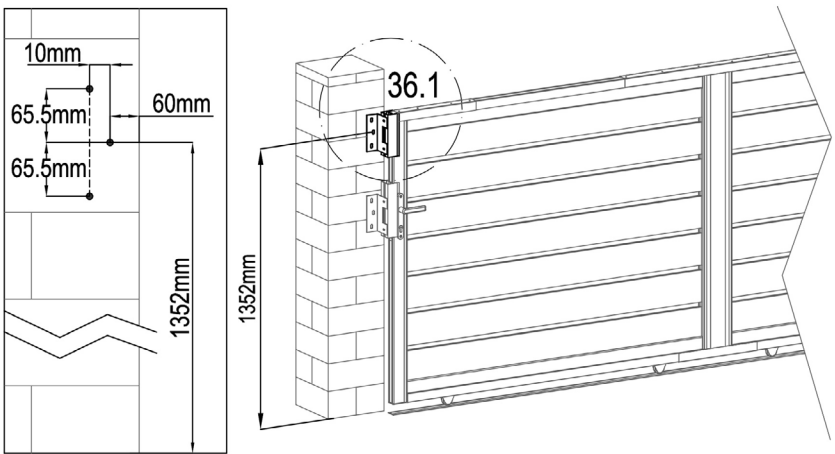

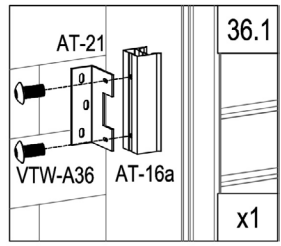
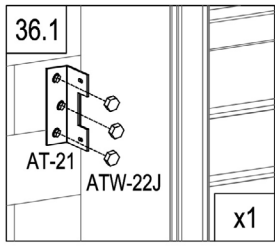

	AT-16a	1
	AT-21	1
	VTW-A36	2
	VTW-A31	3
	ATW-22J	3

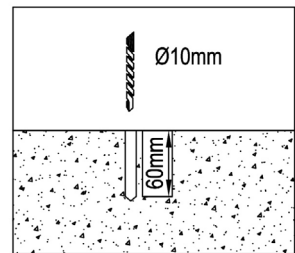
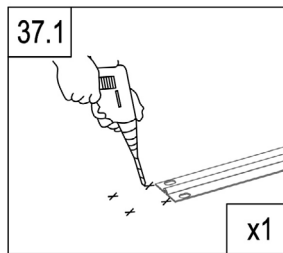
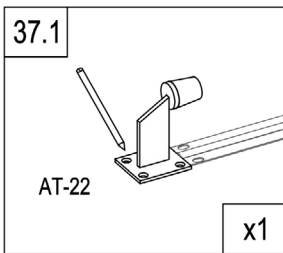
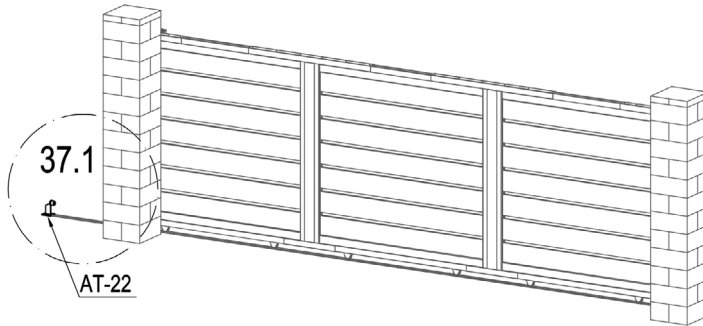

R



	AT-22	1
	VTW-A31	4
	ATW-22J	4

