

# CASANOVO

## EIGER 350B140

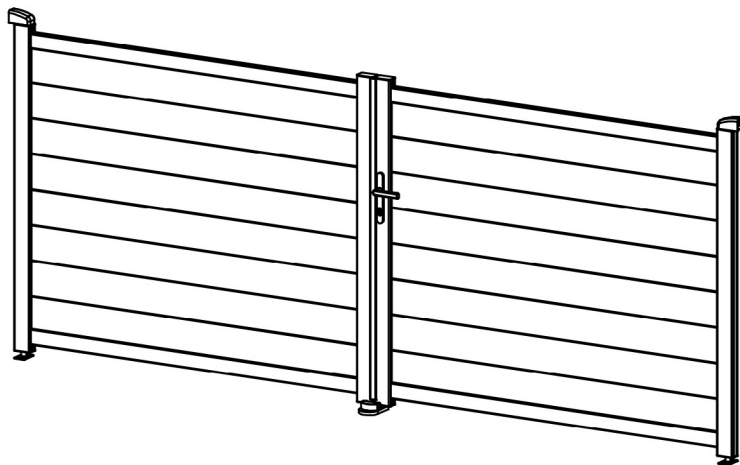

COM-001059 [x1]

COM-001061 [x1]

COM-001060 [x1]





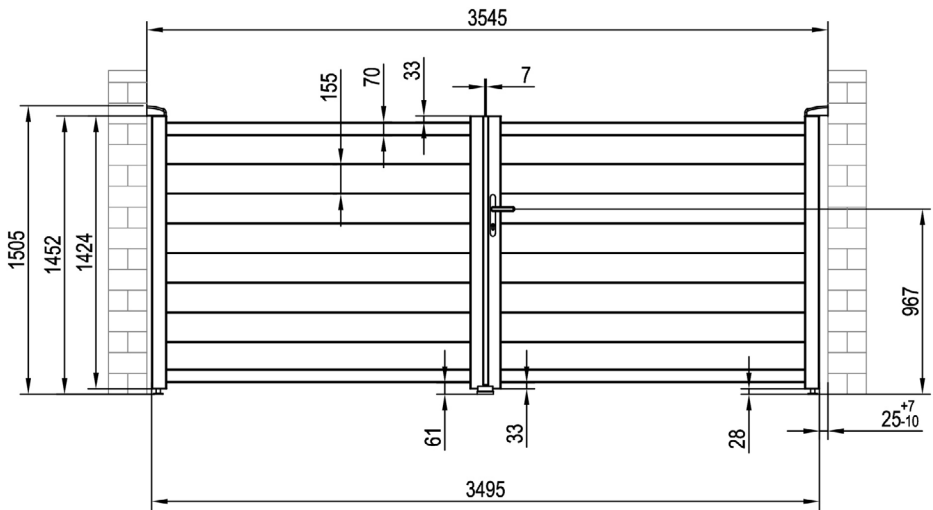

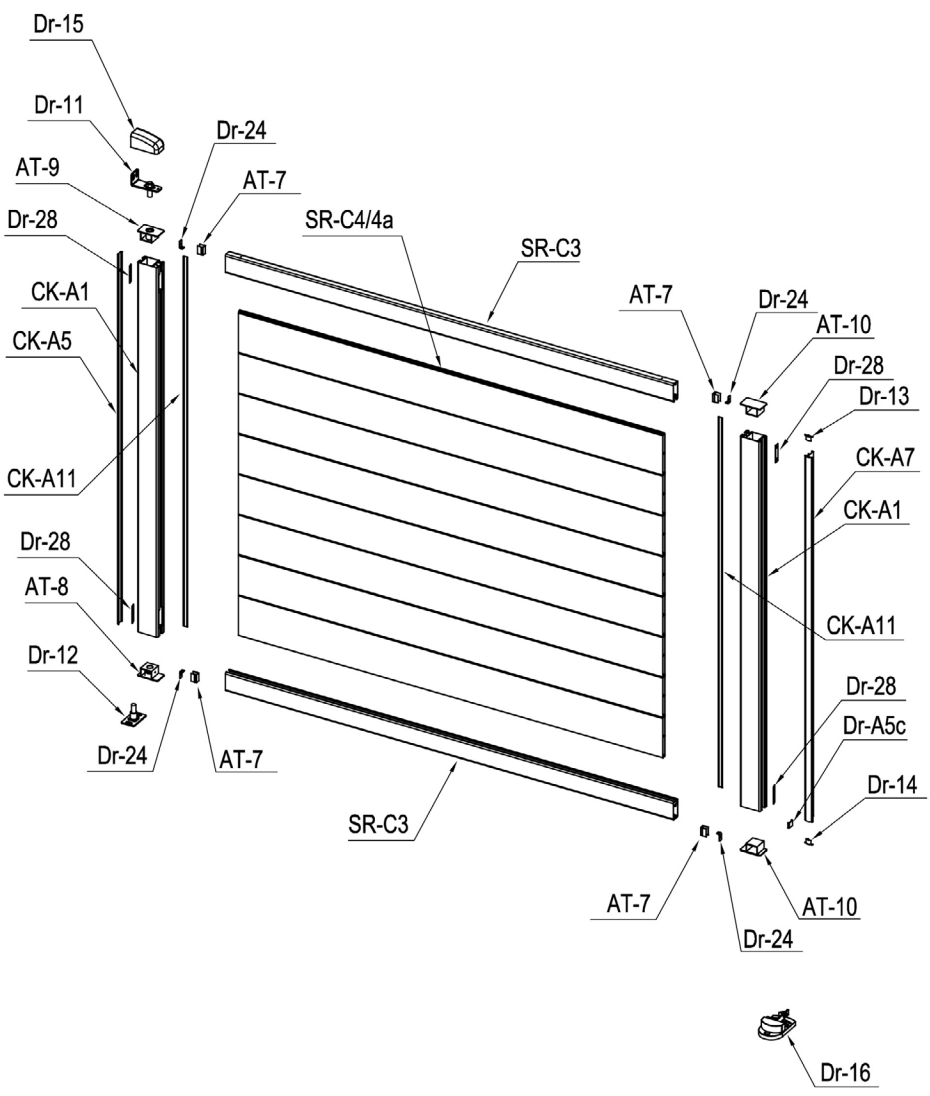

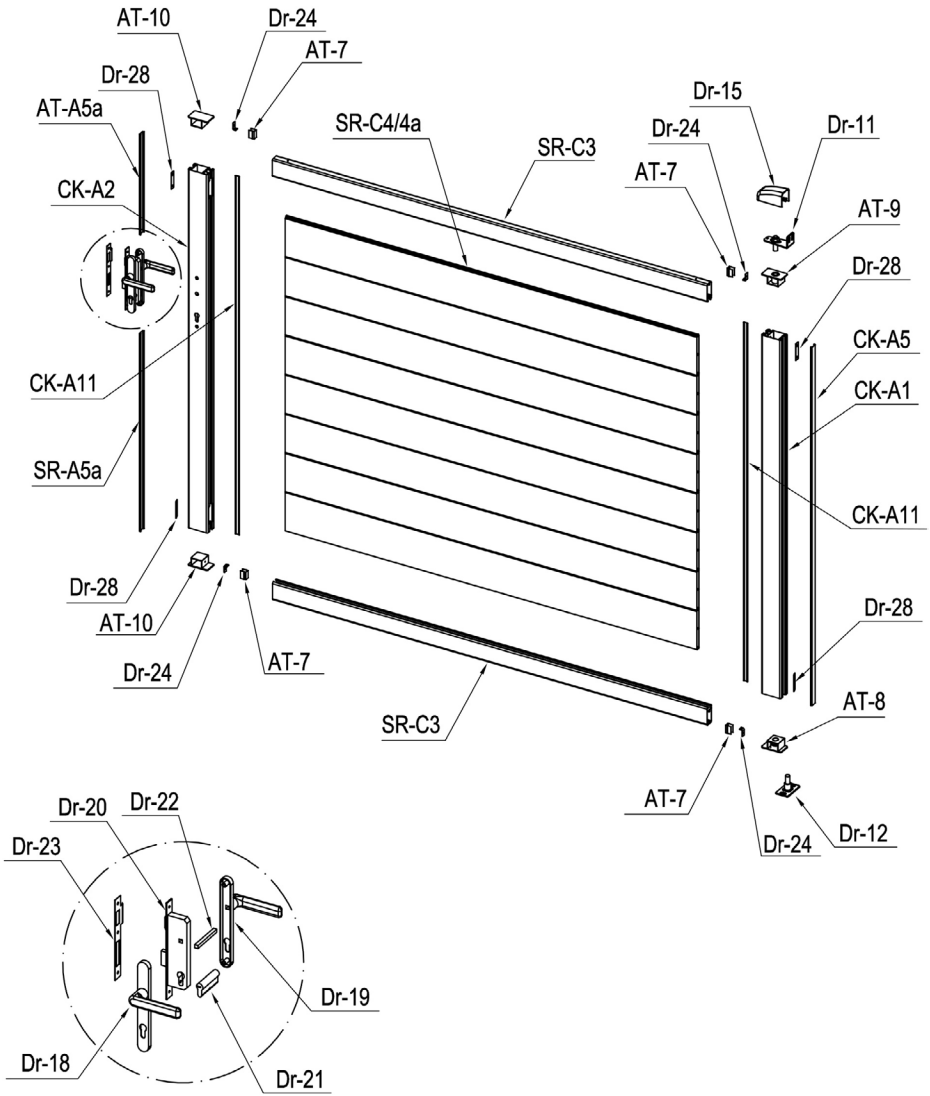































INSTRUCTION MANUAL / NOTICE DE MONTAGE / MONTAGEANLEITUNG / MANUAL DE MONTAJE / MANUAL DE MONTAGEM / MANUALE DI MONTAGGIO /  
MONTAGEHANDLEIDING / INSTRUKCJA MONTAŻU / KÄYTTÖOHJEET / BRUKSANVISNING / BRUGSANVISNING / INSTRUCȚIUNI DE ASAMBLARE /  
NAVODILA ZA SESTAVLJANJE / NÁVOD NA MONTÁŽ / ÖSSZESZERELÉSI ÚTMUTATÓ / NÁVOD K MONTÁŽI / UPUTE ZA INSTALACIJU /  
ΟΔΗΓΙΕΣ ΣΥΝΑΡΜΟΛΟΓΗΣΗΣ / SURINKIMO INSTRUKCIJOS / MONTĀŽAS INSTRUKCIJAS











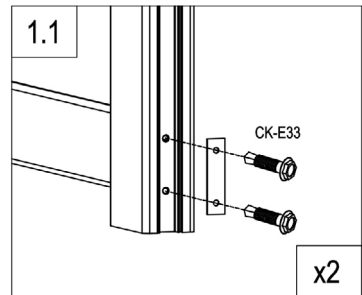
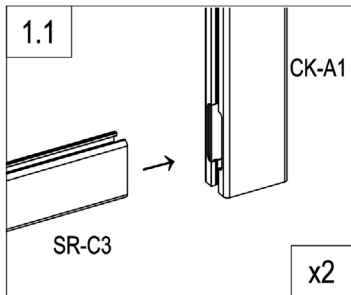
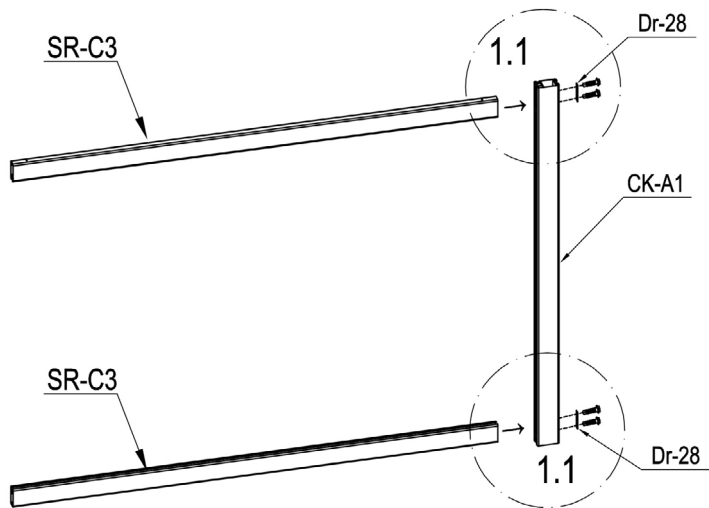

## PART LIST

IMAGE	NO.	L.(mm)	QTY	IMAGE	NO.	L.(mm)	QTY
	CK-A1	1418	3		Dr-17		2
	CK-A2	1418	1		Dr-31		4
	SR-C3	1721	4		Dr-18		1
	SR-C4	1630	14		Dr-19		1
	SR-C4a (+SR-C15)	1630	2		Dr-20		1
	CK-A5	1418	2		Dr-21		1
	AT-A5a	395.5	1		Dr-22		1
	SR-A5a	782	1		Dr-23		1
	Dr-A5c	19.5	1		Dr-24		8
	CK-A11	1418	4		Dr-25		1
	AT-7	29.5	8		Dr-25a		2
	CK-A7	1398	1		Dr-26		3
	AT-8		2		Dr-27		2
	AT-9		2		CK-E30		8
	AT-10		4		CK-E31		8
	Dr-11		2		CK-E32		12
	Dr-12		2		CK-E33		16
	Dr-13		1		CK-E34		3
	Dr-14		1		CK-E35		3
	Dr-15		2		CK-E36		64
	Dr-16		1		Dr-28		8

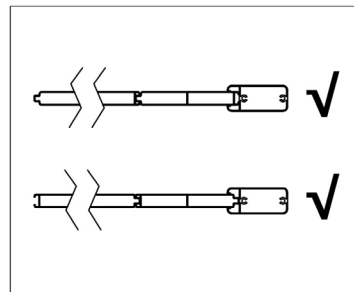
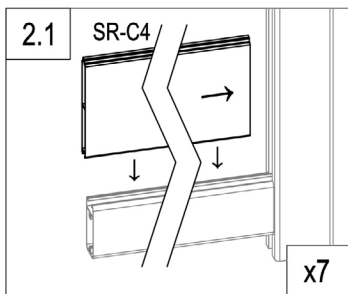
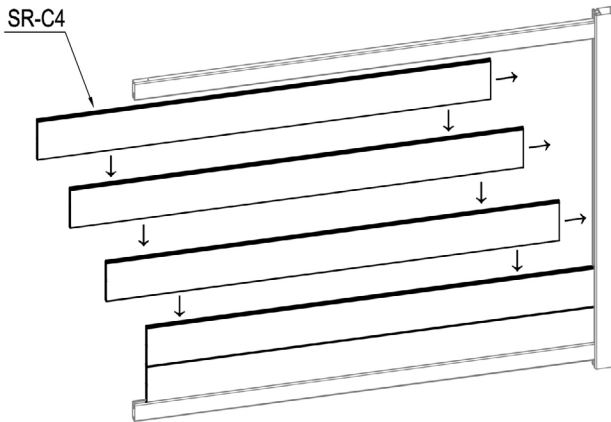

	CK-A1	1
	SR-C3	2
	Dr-28	2
	CK-E33	4



	SR-C4	7
---	-------	---

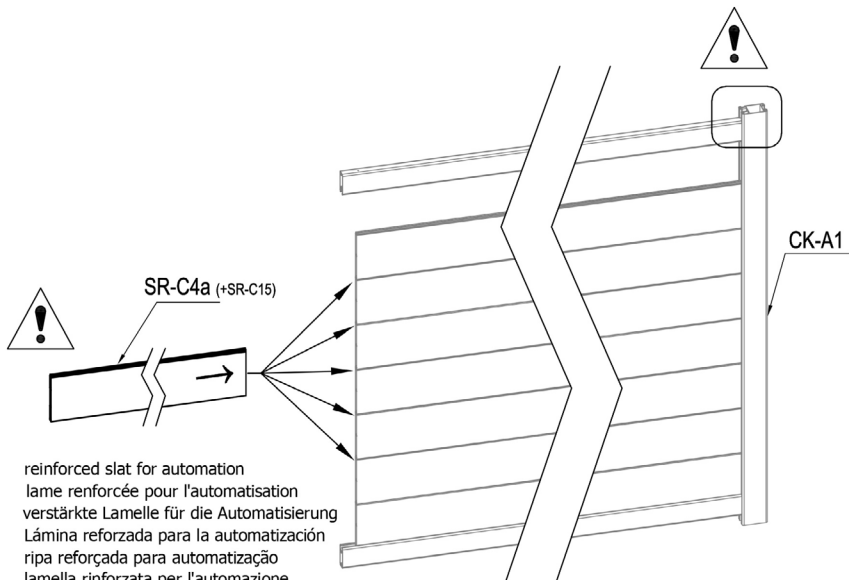



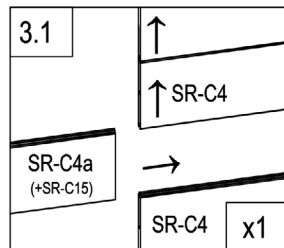
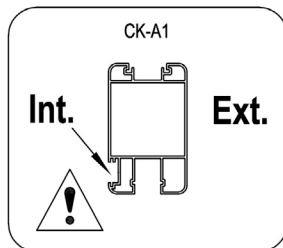
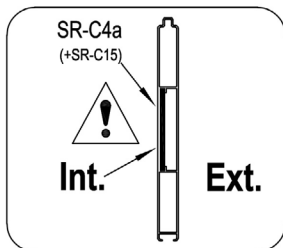

- EN: reinforced slat for automation
- FR: lame renforcée pour l'automatisation
- DE: verstärkte Lamelle für die Automatisierung
- ES: Lámina reforzada para la automatización
- PT: ripa reforçada para automatização
- IT: lamella rinforzata per l'automazione
- NL: versterkte lat voor automatisering
- PL: wzmocniona listwa do automatyzacji

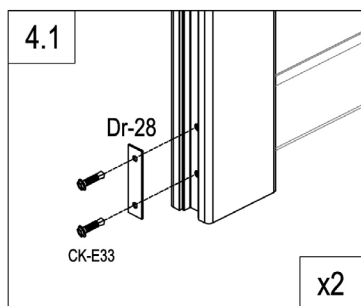
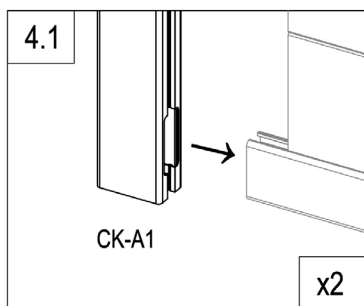
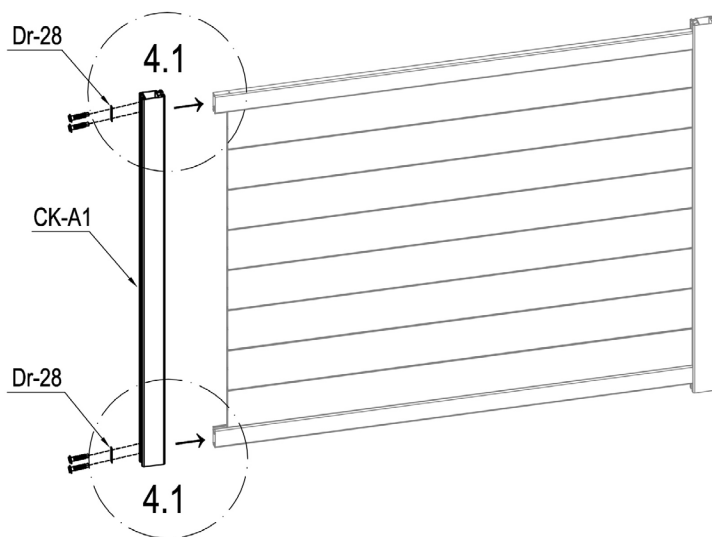

	SR-C4a (+SR-C15)	1
---	------------------	---





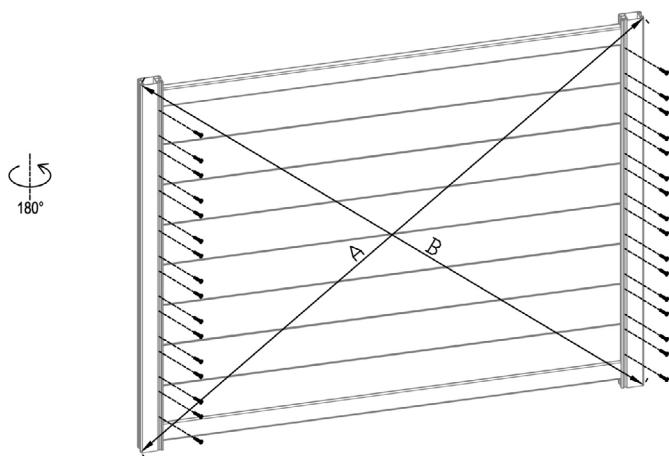

	CK-A1	1
	Dr-28	2
	CK-E33	4

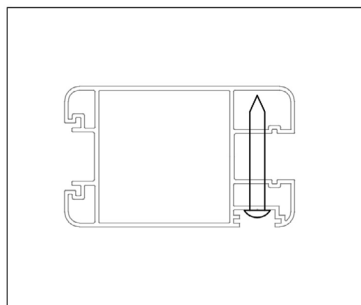
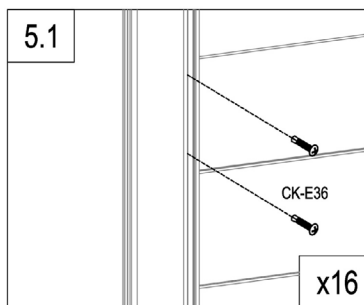

A=B



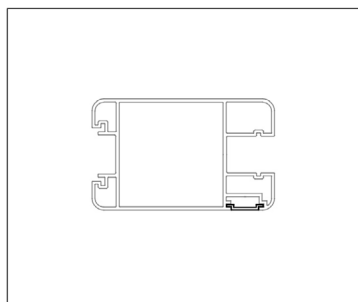
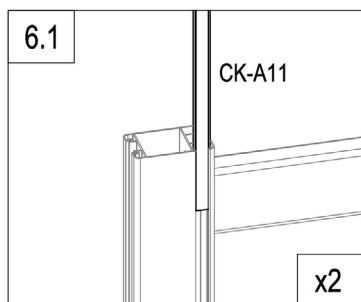
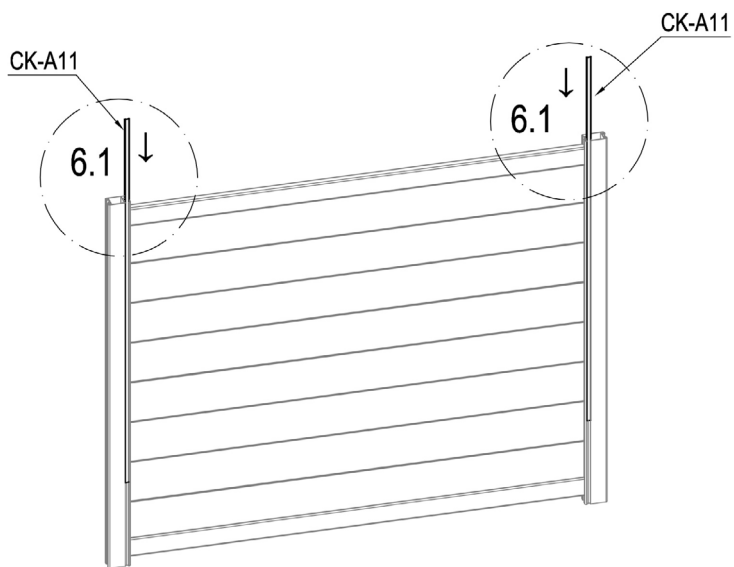

	CK-E36	32
---	--------	----

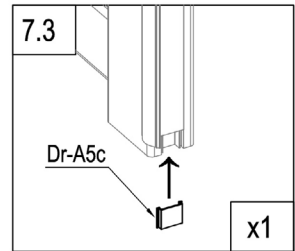
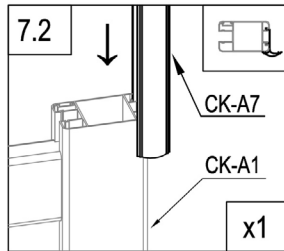
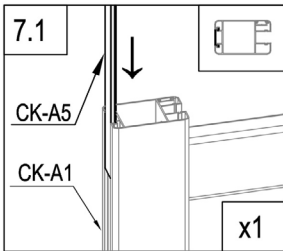
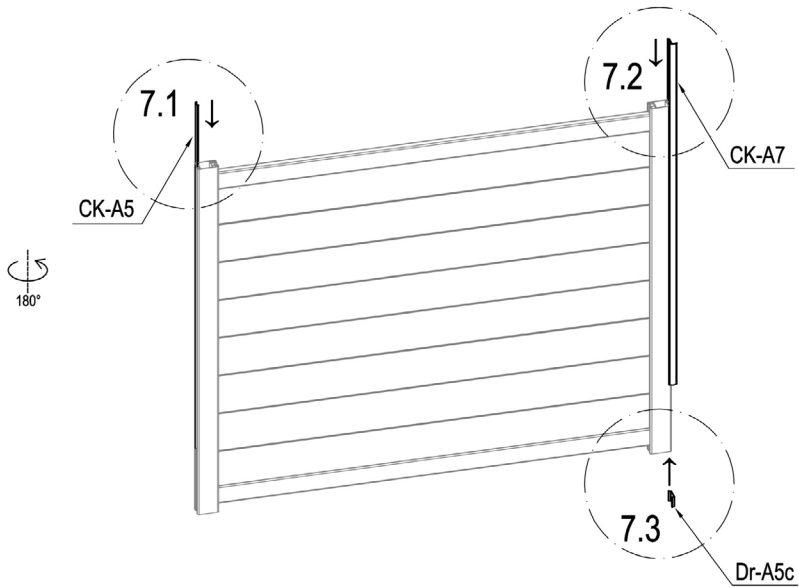

	CK-A11	2
---	--------	---



	CK-A5	1
	Dr-A5c	1
	CK-A7	1

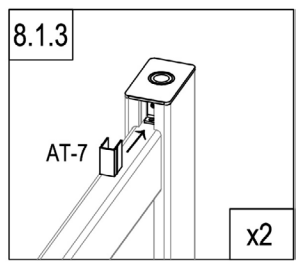
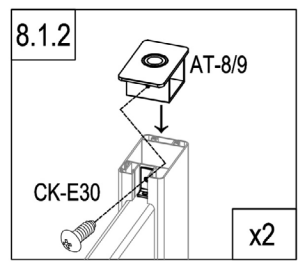
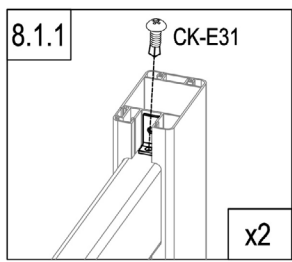
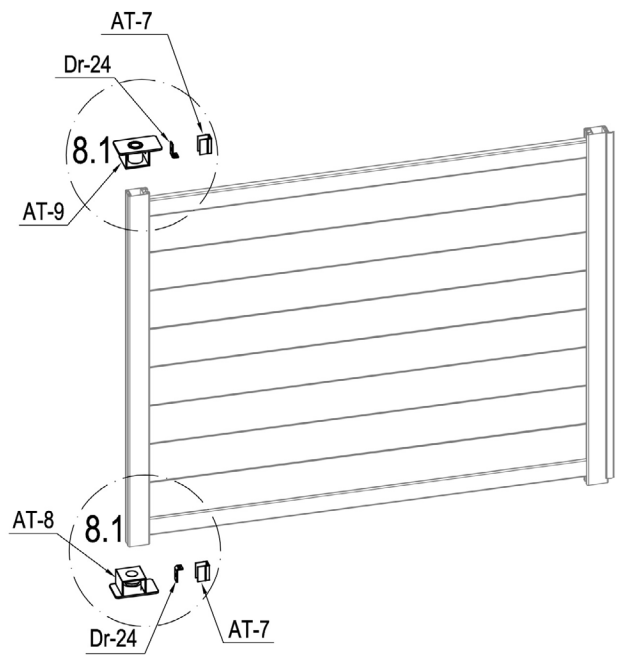

	AT-8	1
	AT-9	1
	Dr-24	2

	AT-7	2
	CK-E30	2
	CK-E31	2

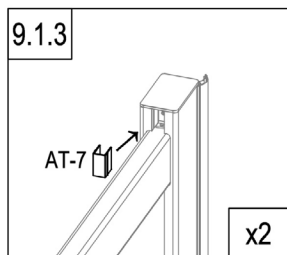
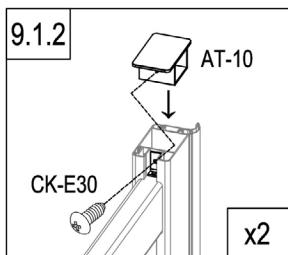
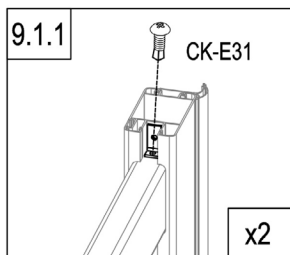
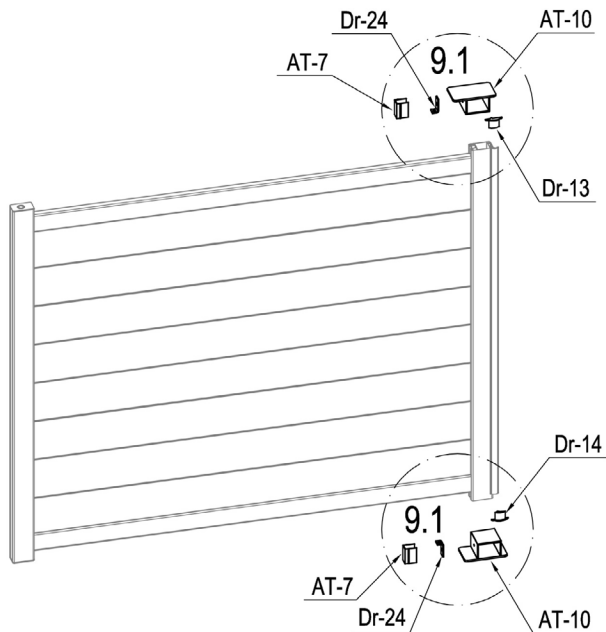

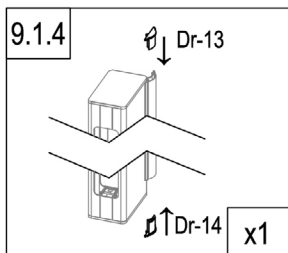

	AT-10	2
	Dr-24	2
	AT-7	2
	Dr-13	1



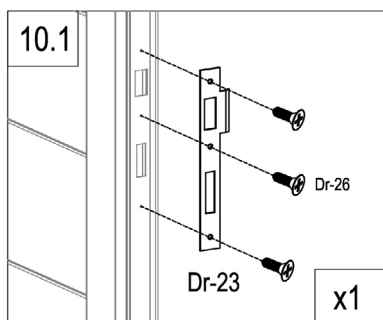
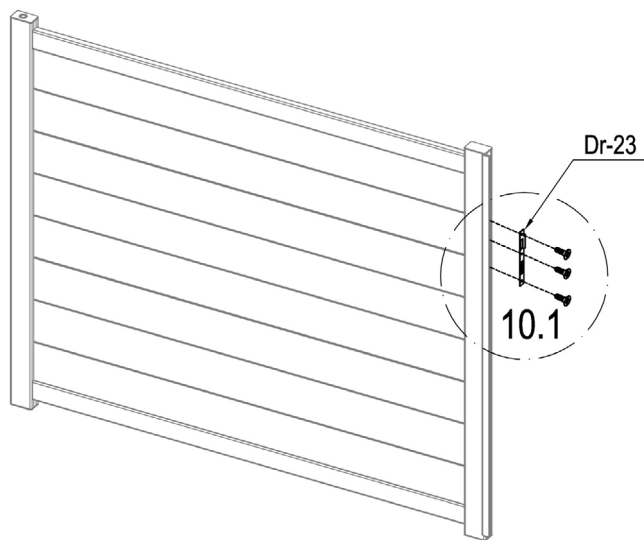



	Dr-14	1
	CK-E30	2
	CK-E31	2

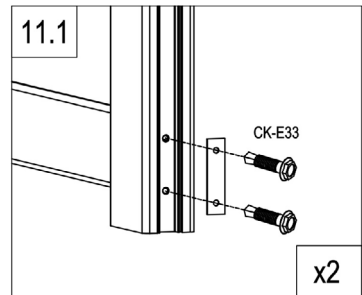
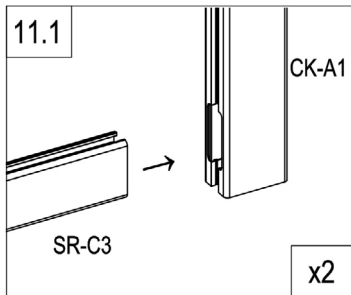
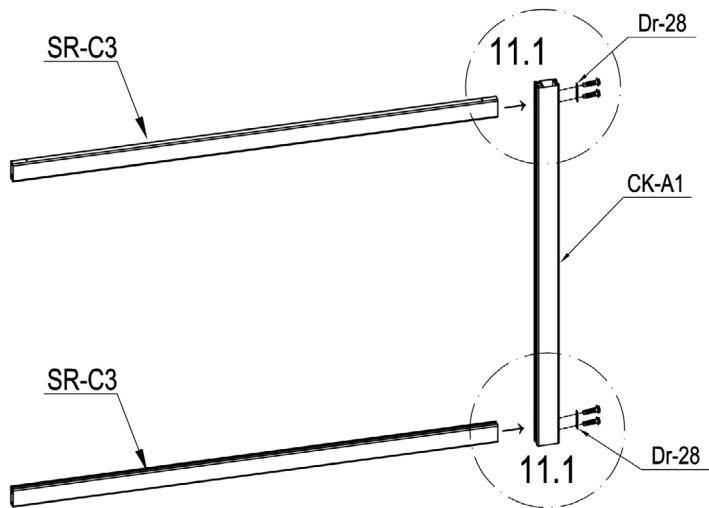



	Dr-23	1
	Dr-26	3



	CK-A1	1
	SR-C3	2
	Dr-28	2
	CK-E33	4

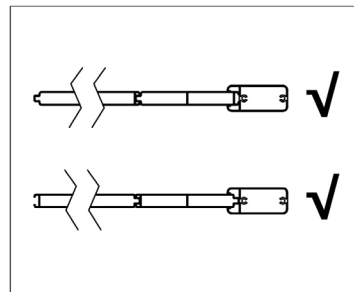
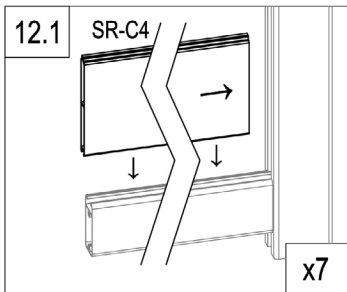
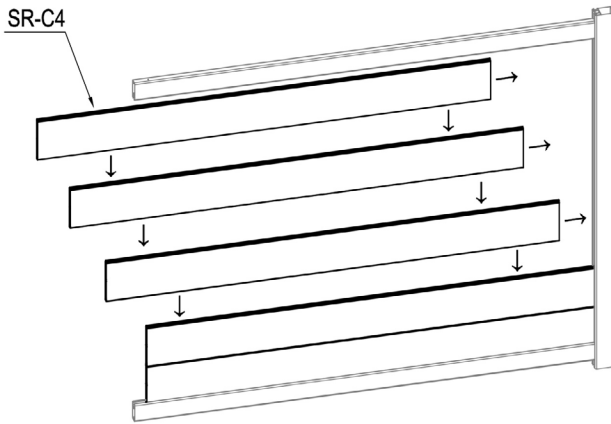



	SR-C4	7
---	-------	---

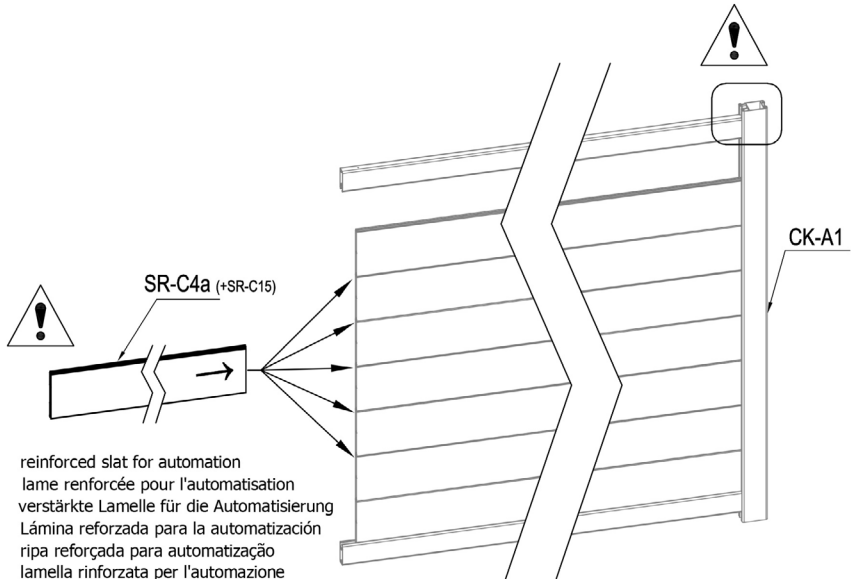

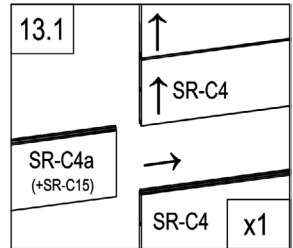
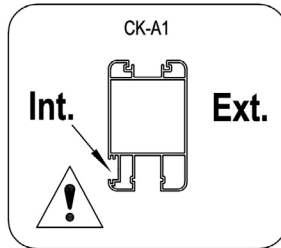
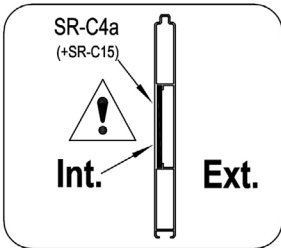

- EN: reinforced slat for automation
- FR: lame renforcée pour l'automatisation
- DE: verstärkte Lamelle für die Automatisierung
- ES: Lámina reforzada para la automatización
- PT: ripa reforçada para automatização
- IT: lamella rinforzata per l'automazione
- NL: versterkte lat voor automatisering
- PL: wzmocniona listwa do automatyzacji

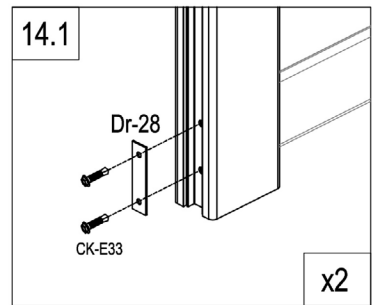
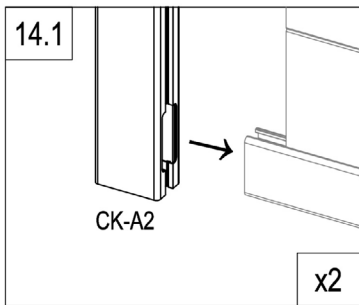
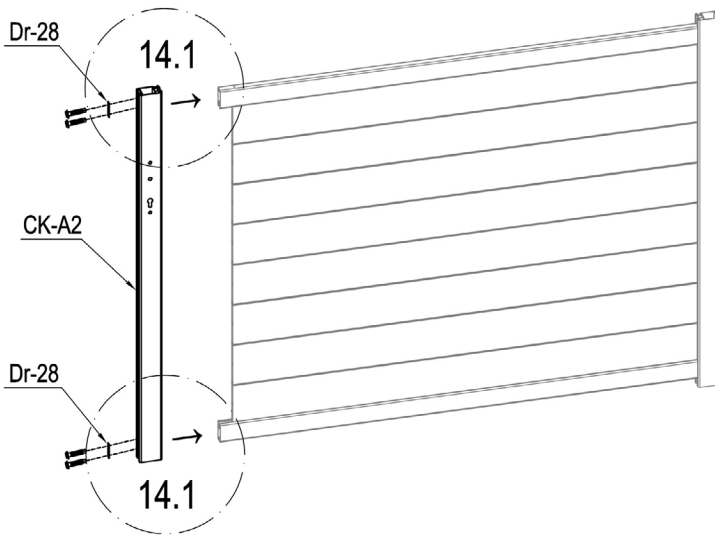

	SR-C4a (+SR-C15)	1
--	------------------	---



	CK-A2	1
	Dr-28	2
	CK-E33	4

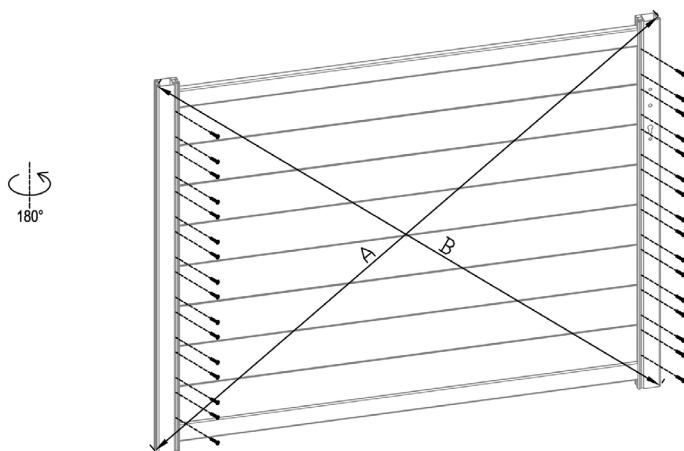

A=B

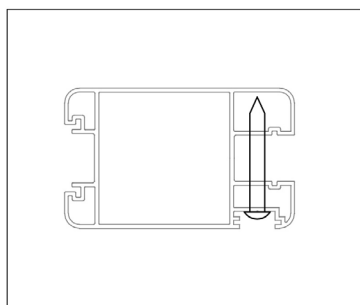
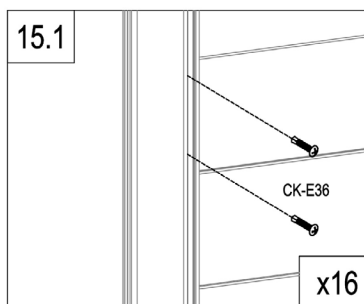

	CK-E36	32
---	--------	----

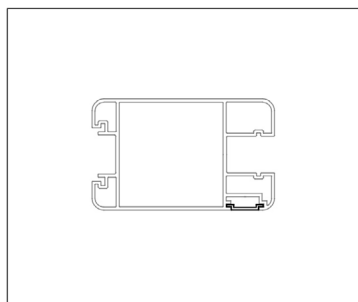
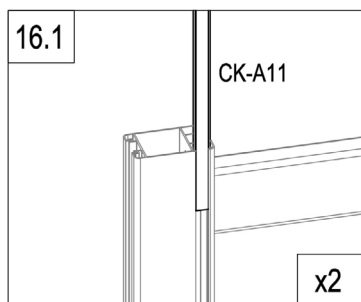
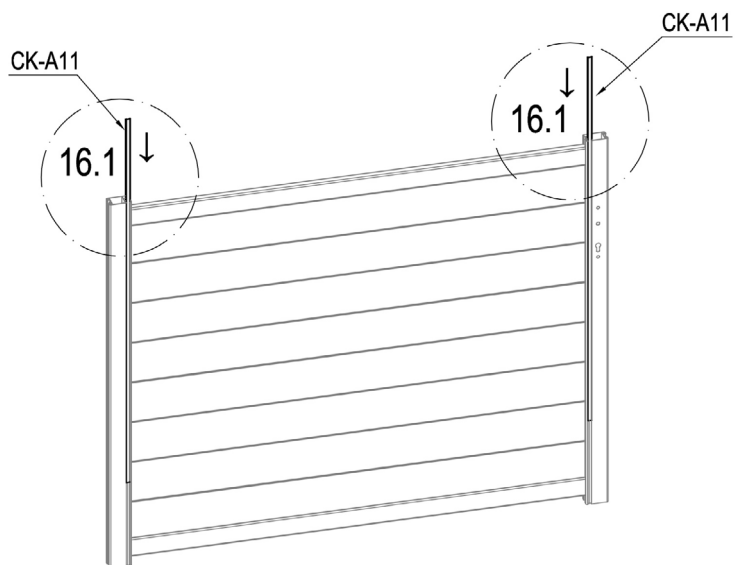

	CK-A11	2
---	--------	---

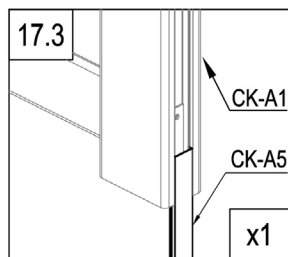
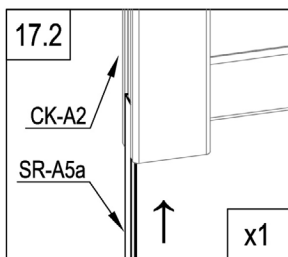
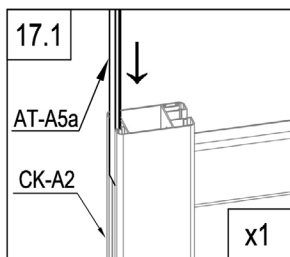
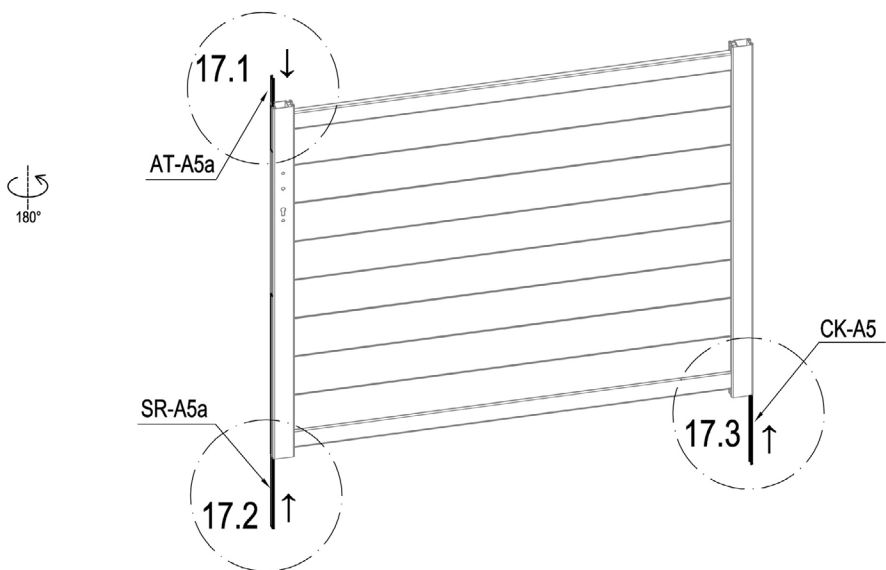

	CK-A5	1
	AT-A5a	1
	SR-A5a	1

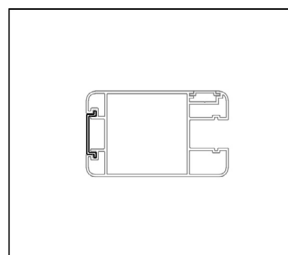

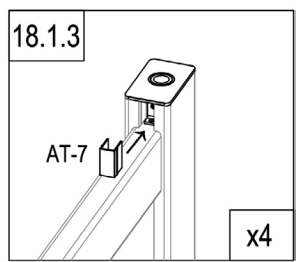
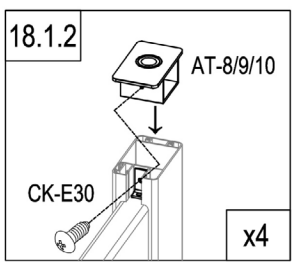
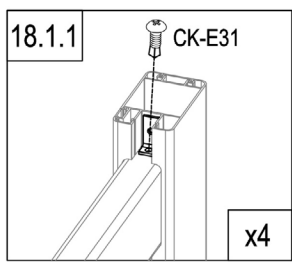
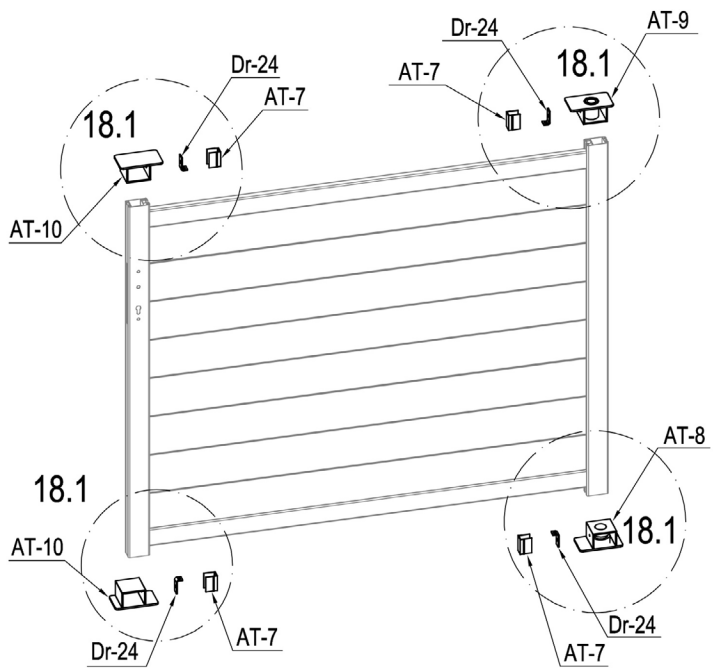

	AT-8	1
	AT-9	1
	AT-10	2
	Dr-24	4

	AT-7	4
	CK-E30	4
	CK-E31	4

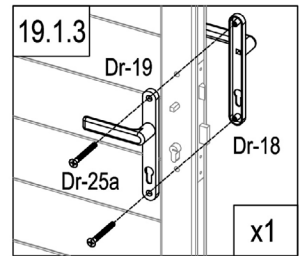
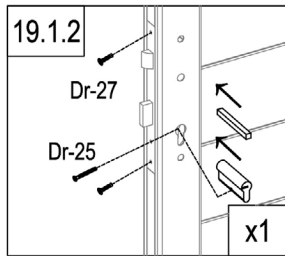
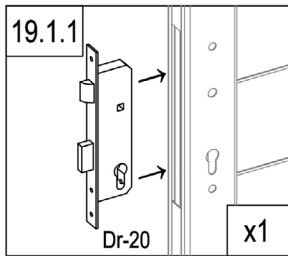
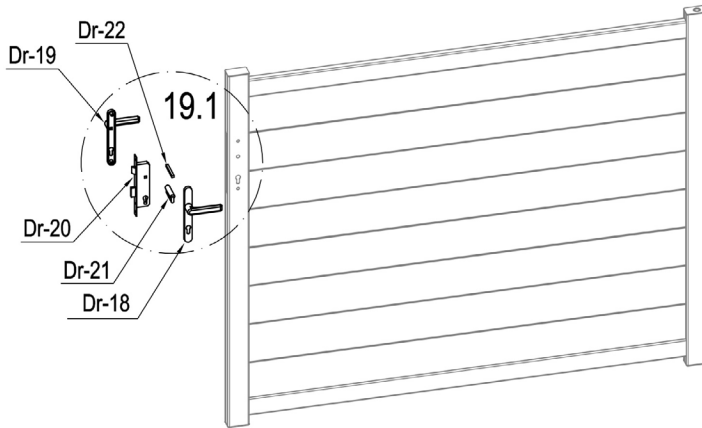



	Dr-20	1
	Dr-21	1
	Dr-22	1
	Dr-25	1

	Dr-18	1
	Dr-19	1
	Dr-25a	2
	Dr-27	2

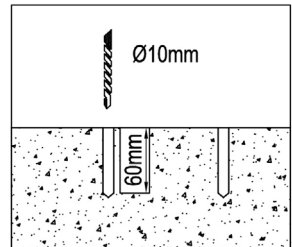
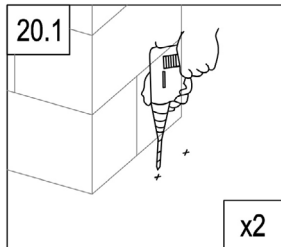
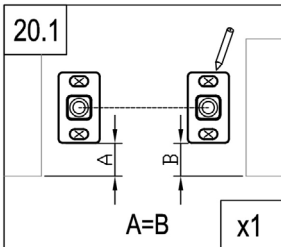
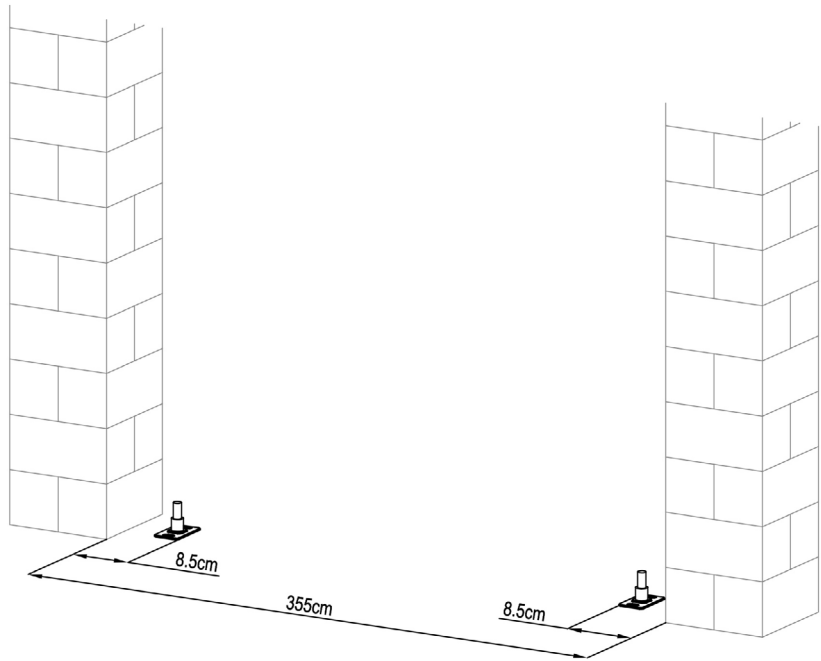





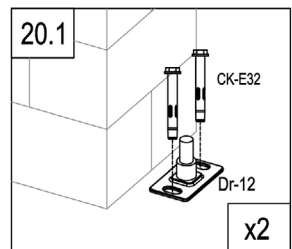

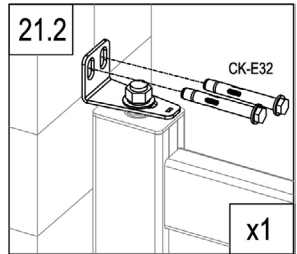
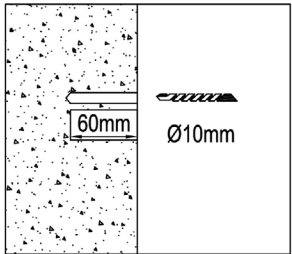
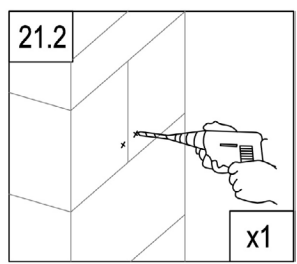
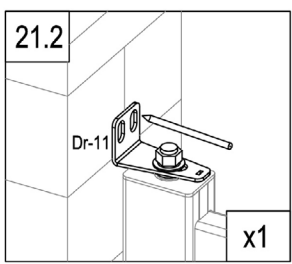
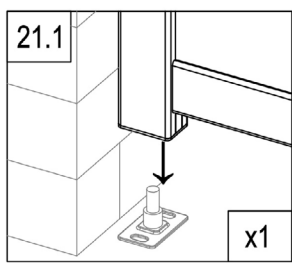
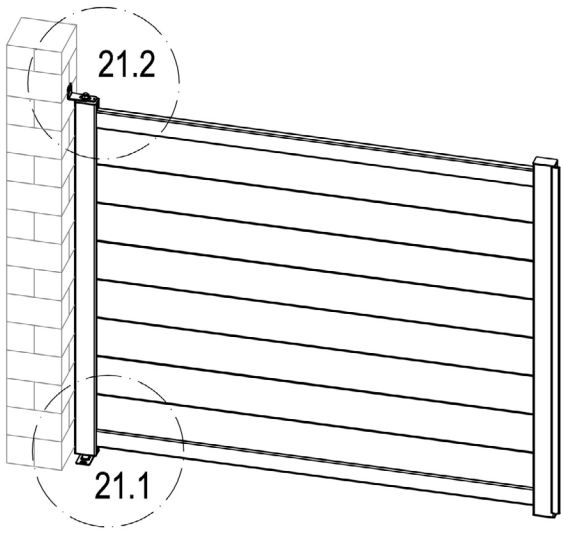
	Dr-12	2
	CK-E32	4



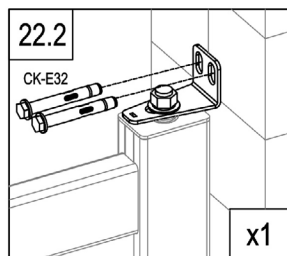
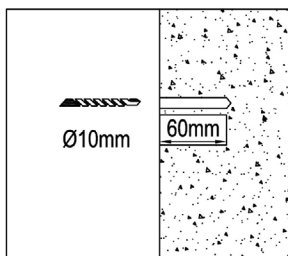
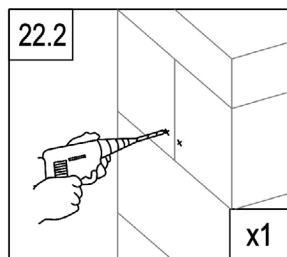
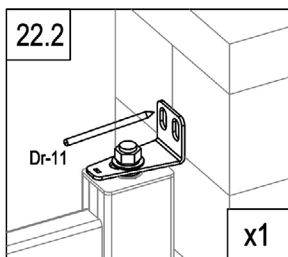
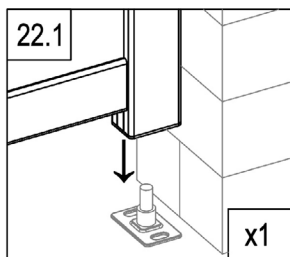
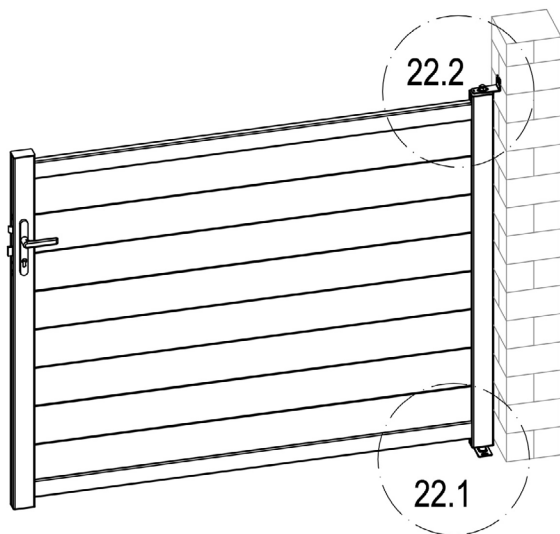

	Dr-11	1
	CK-E32	2





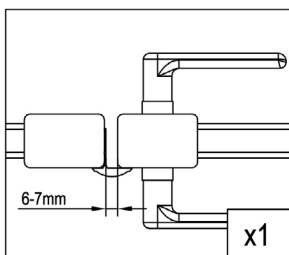
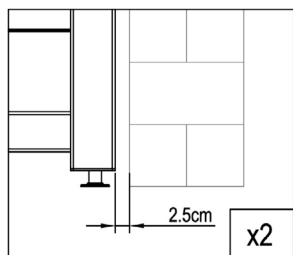
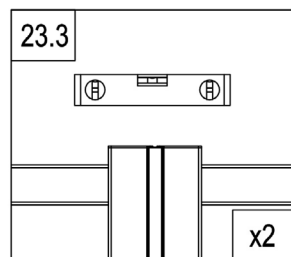
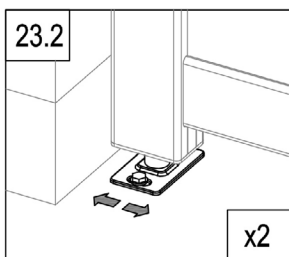
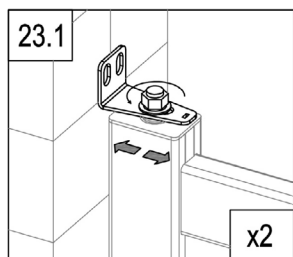
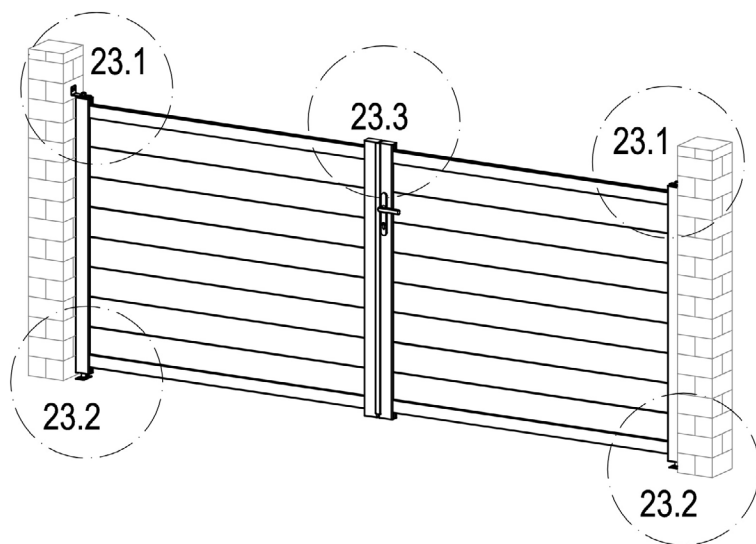

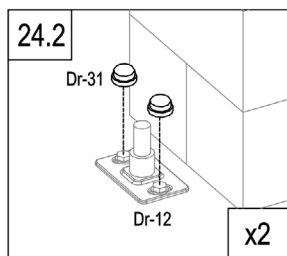
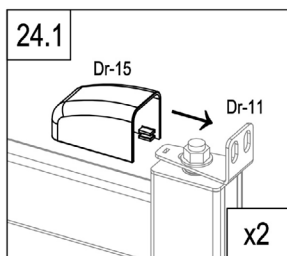
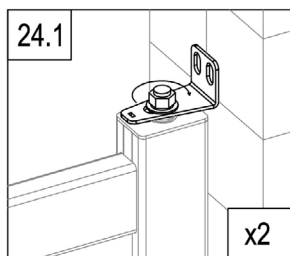
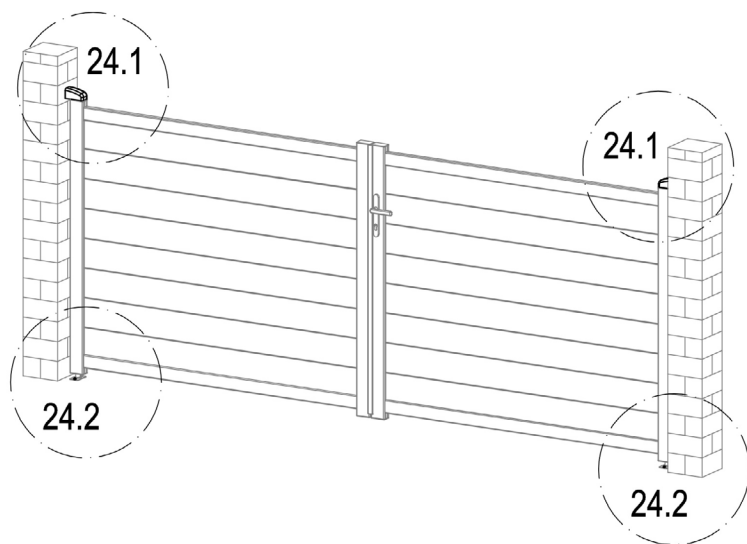
	Dr-11	1
	CK-E32	2



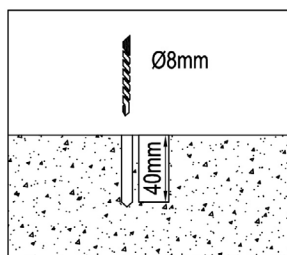
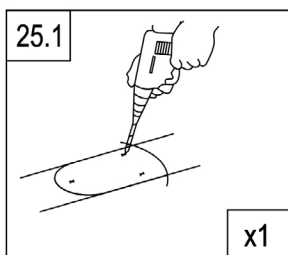
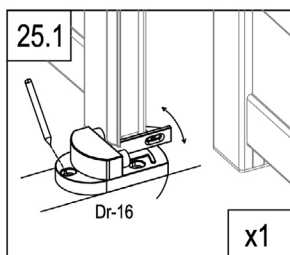
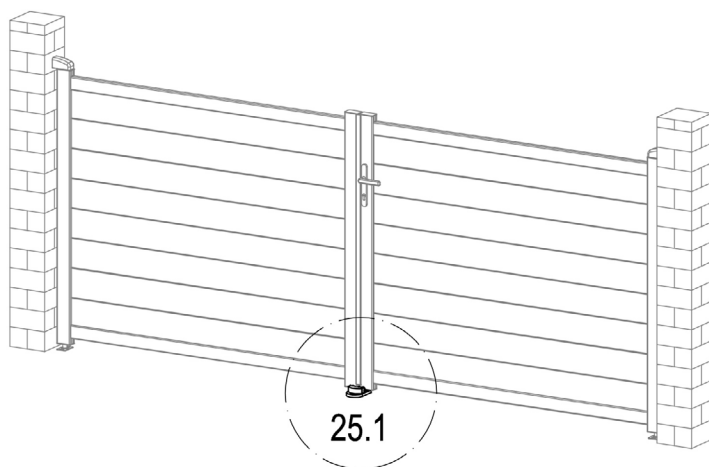



	Dr-15	2
	Dr-31	4

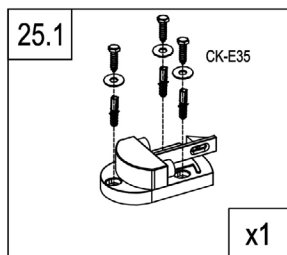

	Dr-16	1
	CK-E34	3
	CK-E35	3

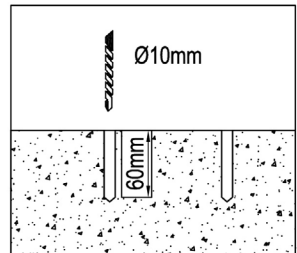
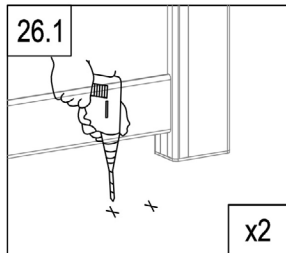
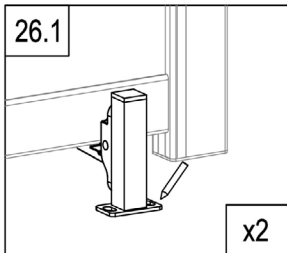
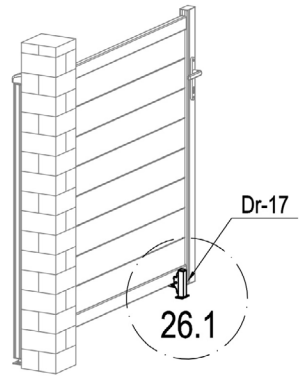
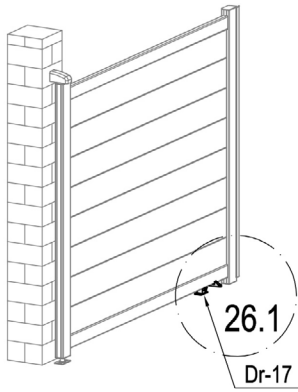



	CK-E32	4
	Dr-17	2

