

CASANOVO

CIMONE 350B160

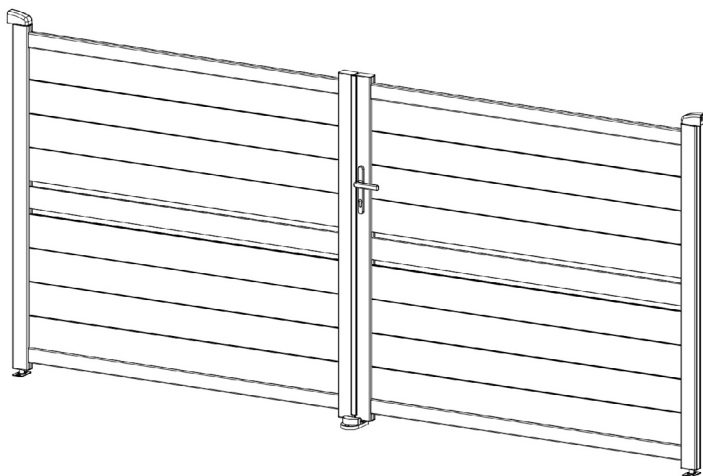

COM-001184 [x1]

COM-001185 [x1]

COM-001186 [x1]



INSTRUCTION MANUAL / NOTICE DE MONTAGE / MONTAGEANLEITUNG / MANUAL DE MONTAJE / MANUAL DE MONTAGEM / MANUALE DI MONTAGGIO /
MONTAGEHANDLEIDING / INSTRUKCJA MONTAŻU / KÄYTTÖOHJEET / BRUGSANVISNING / INSTRUCȚIUNI DE ASAMBLARE /
NAVODILA ZA SESTAVLJANJE / NÁVOD NA MONTÁŽ / ÖSSZESZERELÉSI ÚTMUTATÓ / NÁVOD K MONTÁŽI / UPUTE ZA INSTALACIJU /
ΟΔΗΓΙΕΣ ΣΥΝΑΡΜΟΛΟΓΗΣΗΣ / SURINKIMO INSTRUKCIJOS / MONTĀŽAS INSTRUKCIJAS

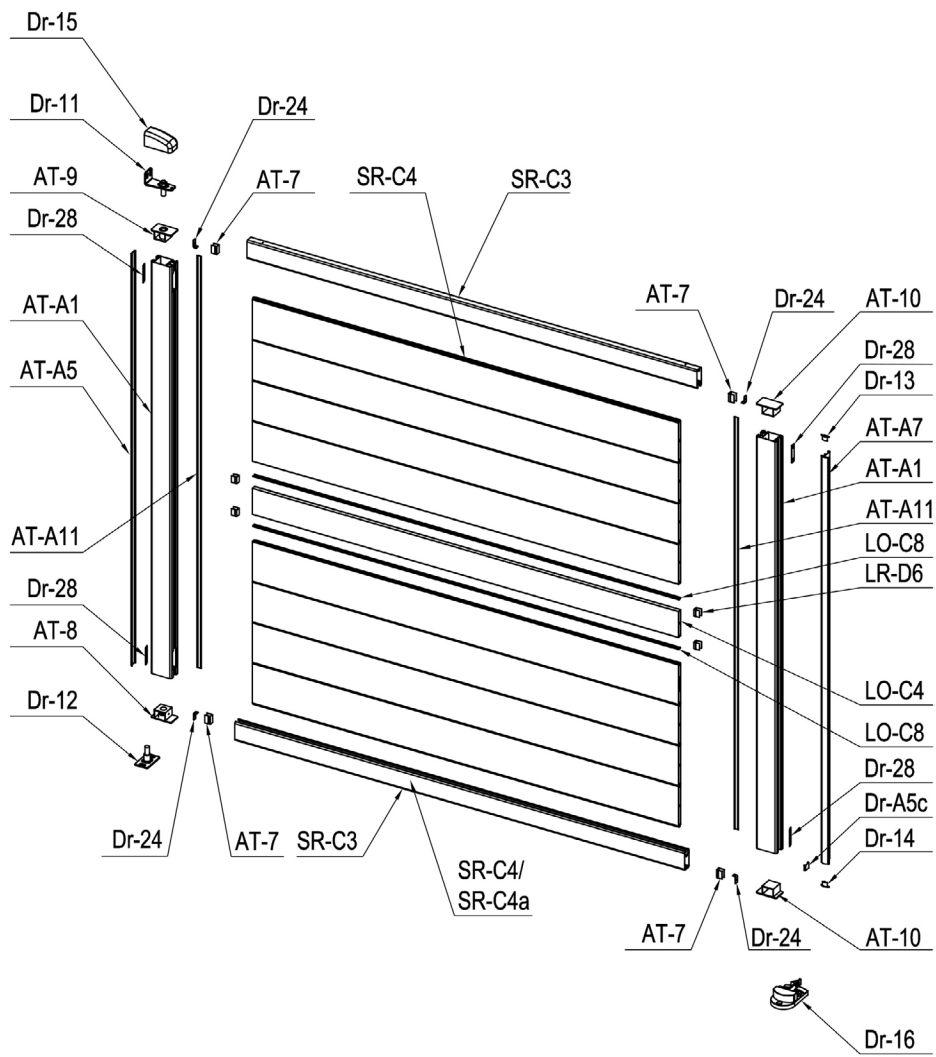

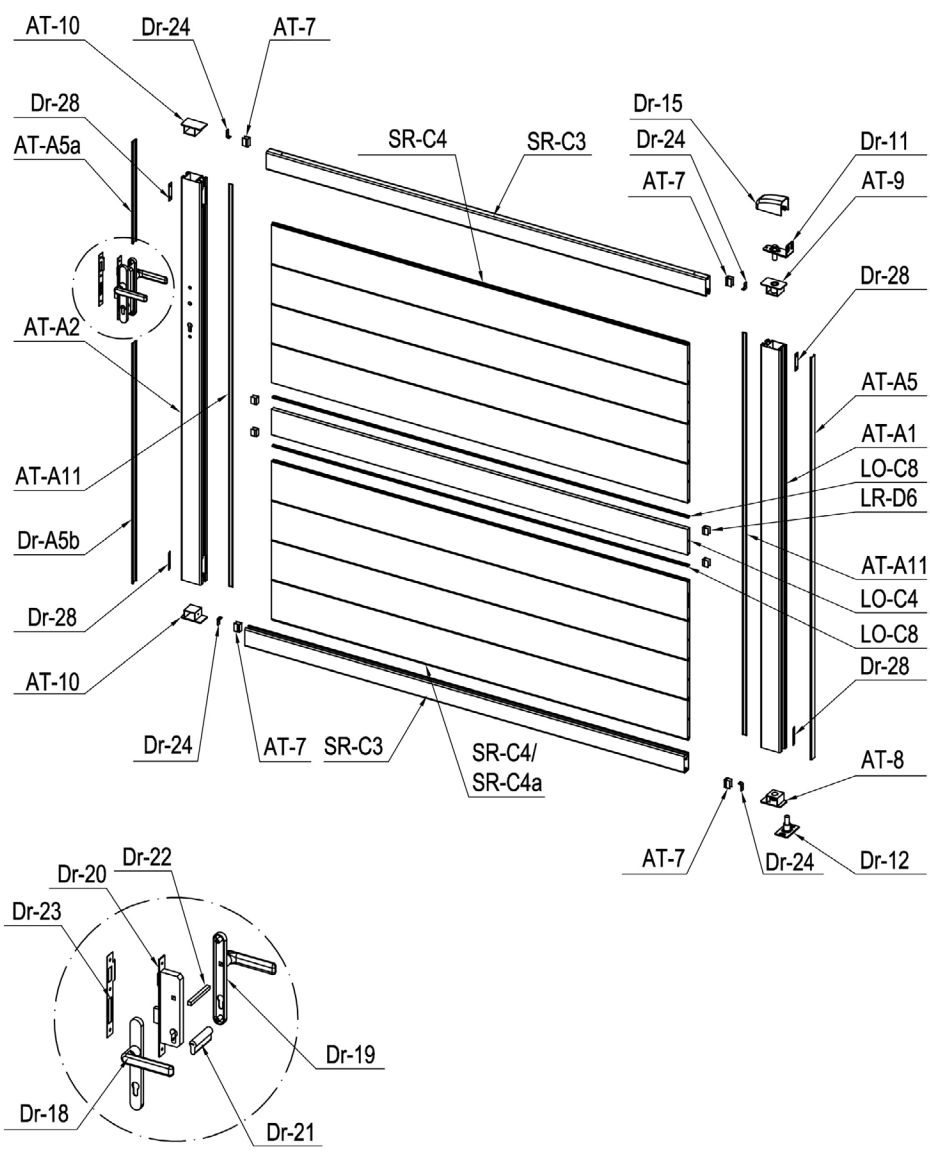
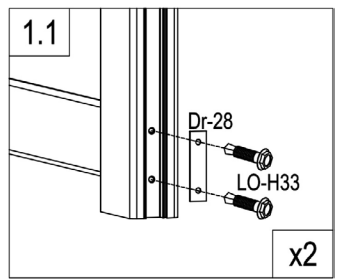
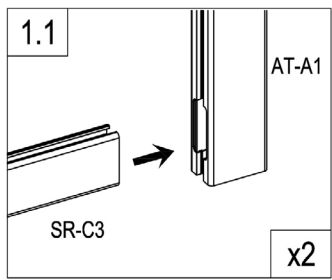
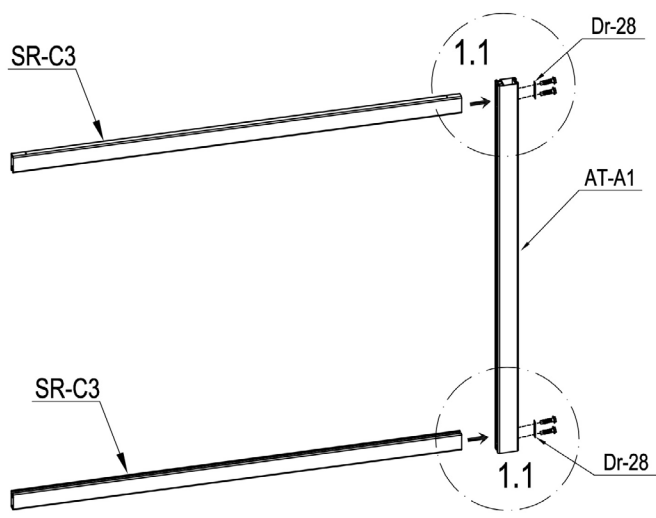



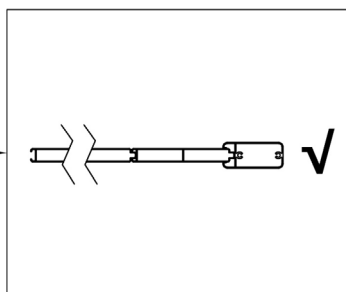
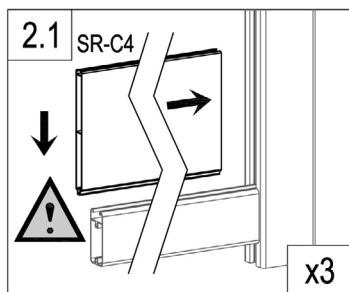
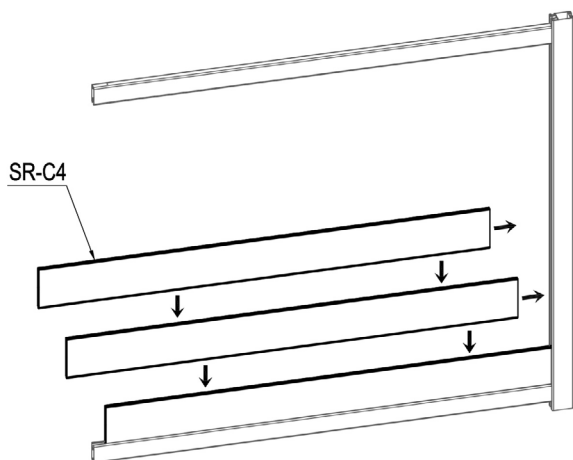



IMAGE	NO.	L.(mm)	QTY	IMAGE	NO.	L.(mm)	QTY
	AT-A1	1573	3		Dr-15		2
	AT-A2	1573	1		Dr-16		1
	SR-C3	1721	4		Dr-17		2
	SR-C4a (+SR-C15)	1630	2		Dr-31		4
	SR-C4	1630	14		Dr-18		1
	LO-C4	1630	2		Dr-19		1
	AT-A5	1573	2		Dr-20		1
	AT-A5a	395.5	1		Dr-21		1
	Dr-A5b	937	1		Dr-22		1
	Dr-A5c	19.5	1		Dr-23		1
	AT-A11	1573	4		Dr-25		1
	AT-7	29.5	8		Dr-25a		2
	LR-D6	25	8		Dr-26		3
	LO-C8	1629	4		Dr-27		2
	AT-A7	1553	1		Dr-24		8
	AT-8		2		Dr-28		8
	AT-9		2		LO-H30	ST4x10	8
	AT-10		4		LO-H31	ST4.2x13	8
	Dr-11		2		LO-H32	M8x60	12
	Dr-12		2		LO-H33	ST5.5x38	16
	Dr-13		1		LO-H34	ST6x40	3
	Dr-14		1		LO-H35	Ø6	3
					LO-H36	ST4.8x38	68



	AT-A1	1
	SR-C3	2
	Dr-28	2
	LO-H33	4



	SR-C4	3
---	-------	---

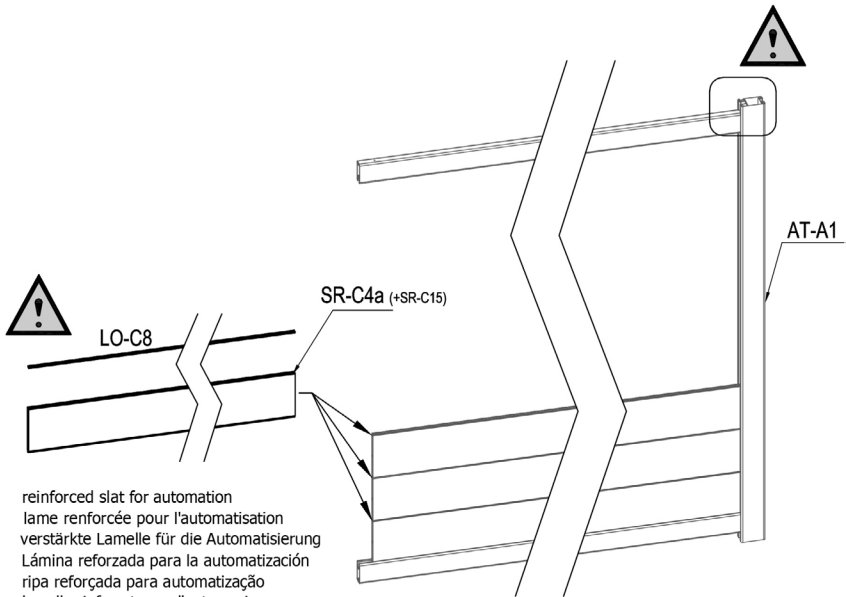

- EN: reinforced slat for automation
- FR: lame renforcée pour l'automatisation
- DE: verstärkte Lamelle für die Automatisierung
- ES: Lámina reforzada para la automatización
- PT: ripa reforçada para automatização
- IT: lamella rinforzata per l'automazione
- NL: versterkte lat voor automatisering
- PL: wzmocniona listwa do automatyzacji

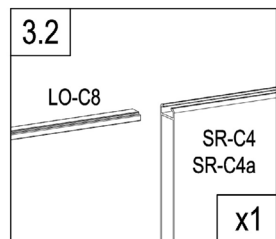
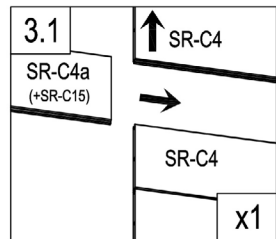
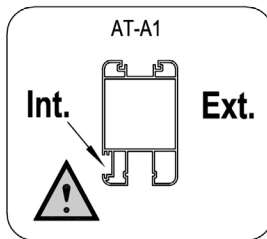
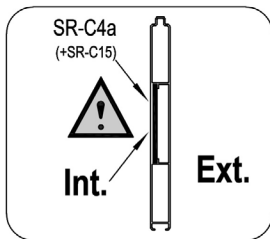

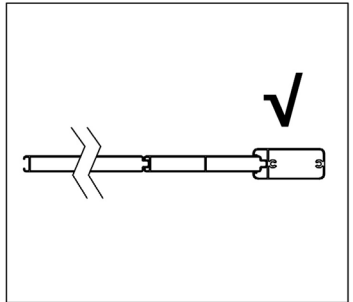
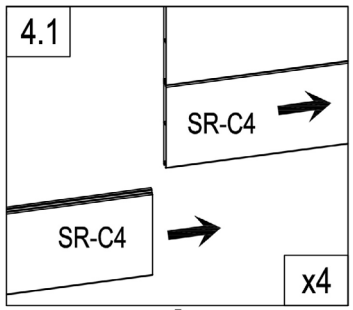
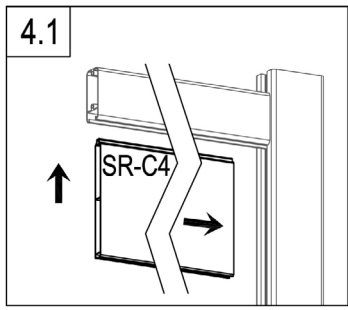
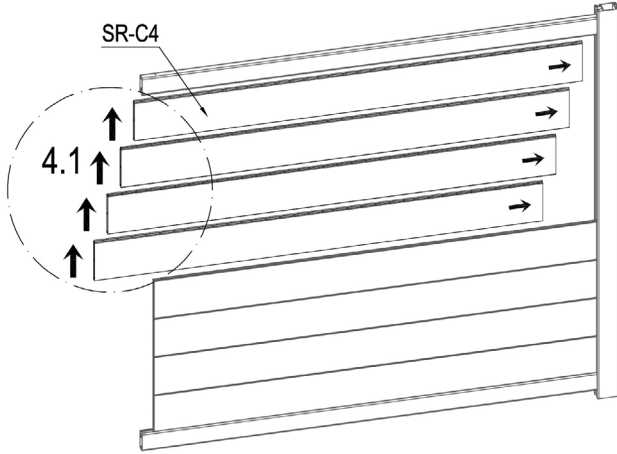

	LO-C8	1
	SR-C4a (+SR-C15)	1



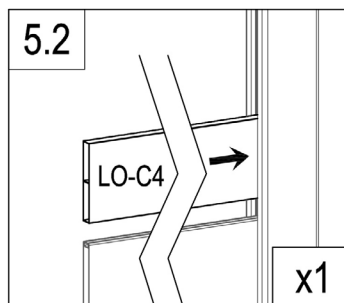
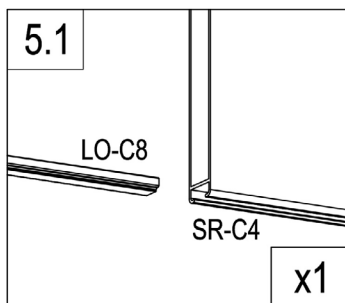
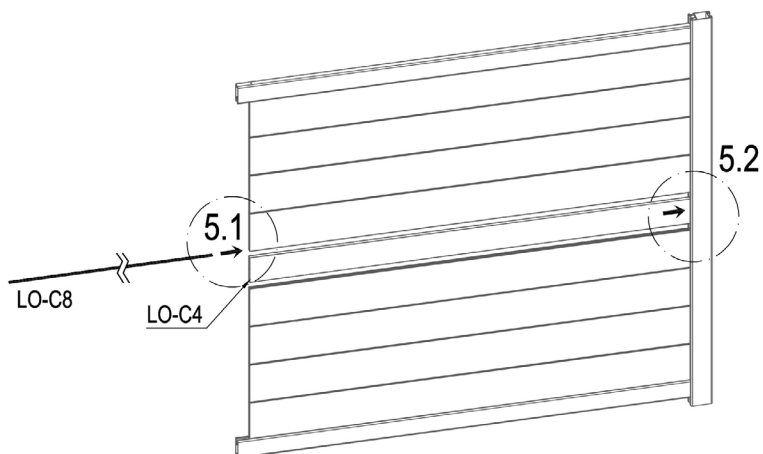

	SR-C4	4
---	-------	---

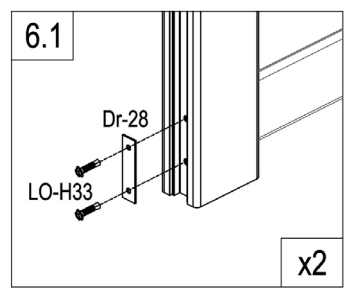
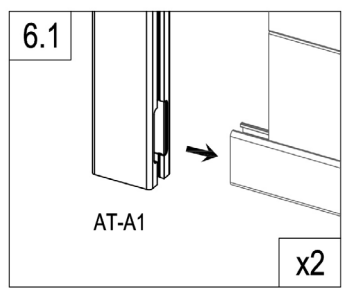
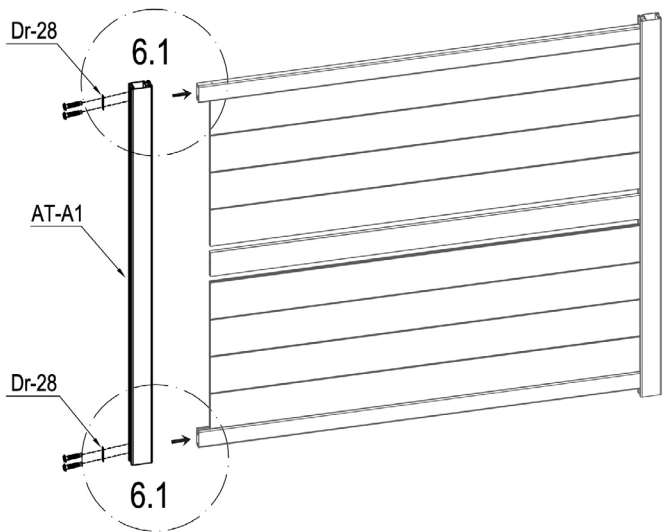

	LO-C4	1
	LO-C8	1



	AT-A1	1
	Dr-28	2
	LO-H33	4

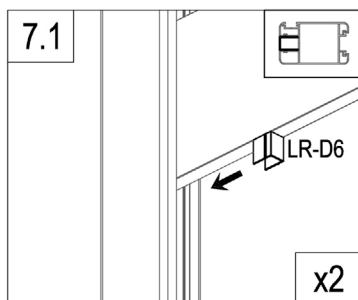
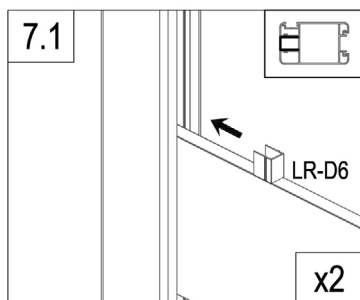
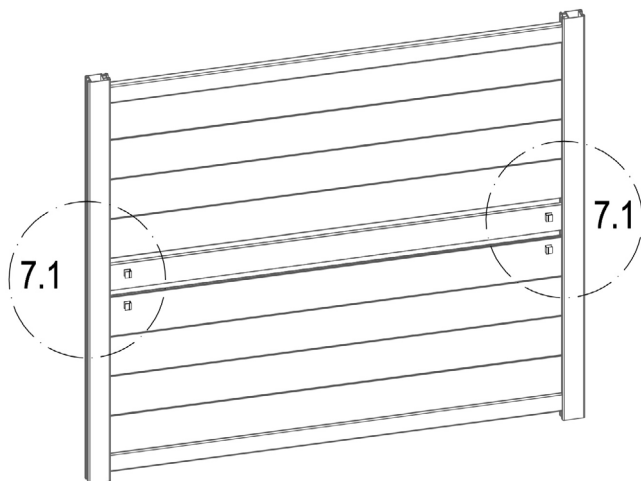

	LR-D6	4
---	-------	---

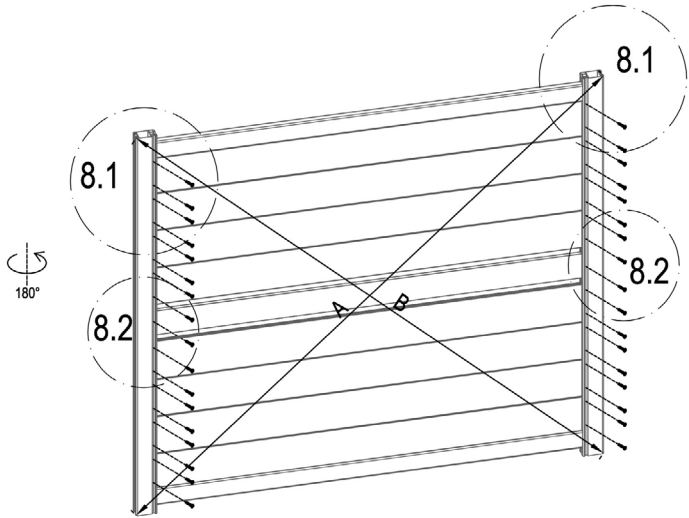

A=B

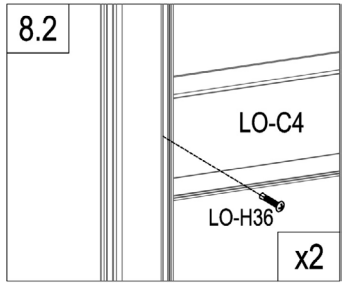
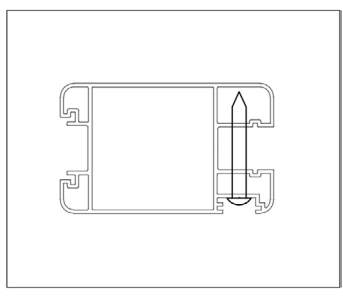
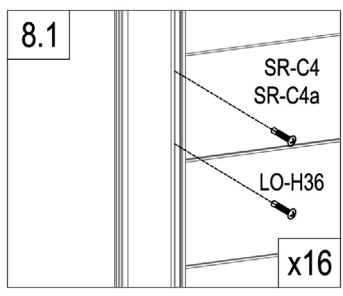

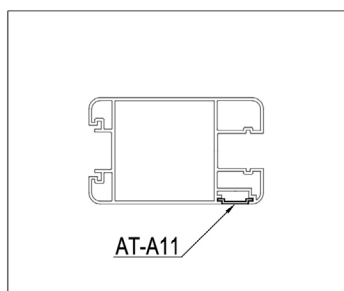
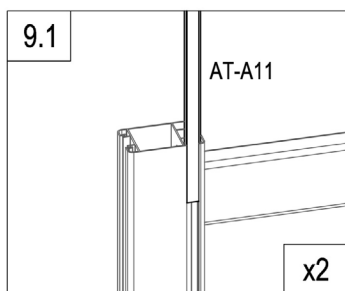
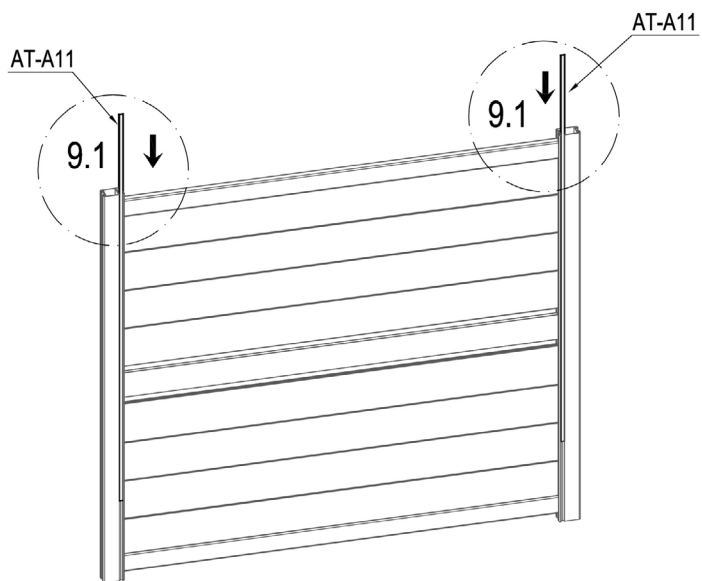

	LO-H36	34
---	--------	----

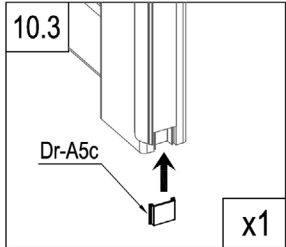
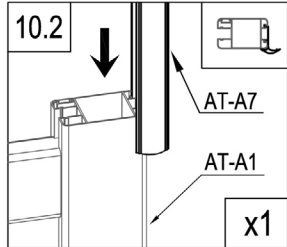
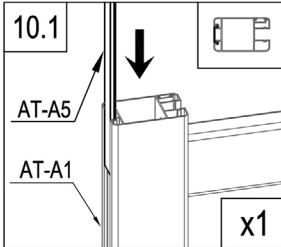
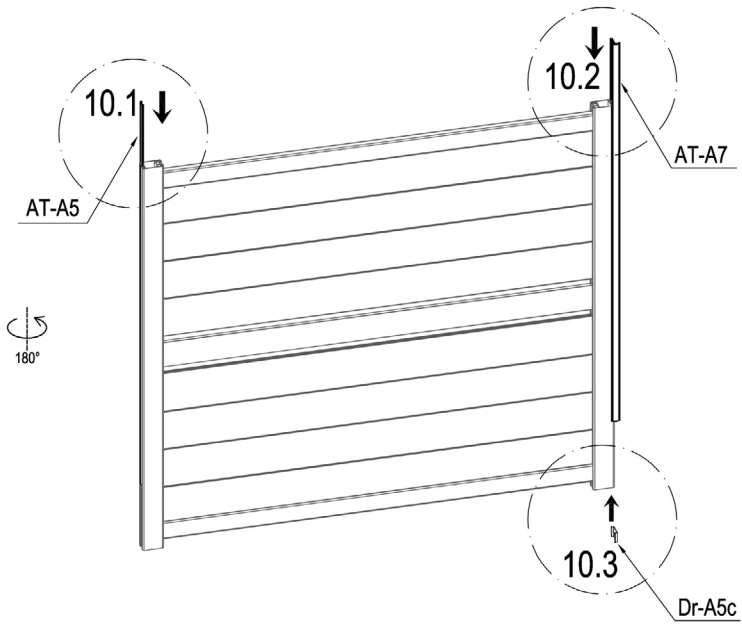

	AT-A11	2
---	--------	---



	AT-A5	1
	Dr-A5c	1
	AT-A7	1

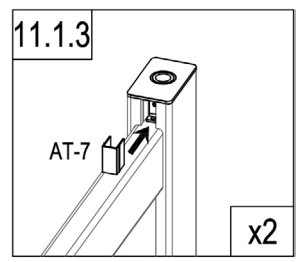
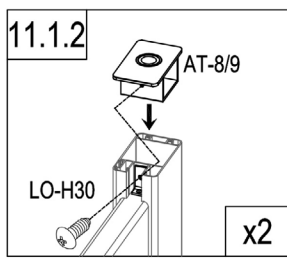
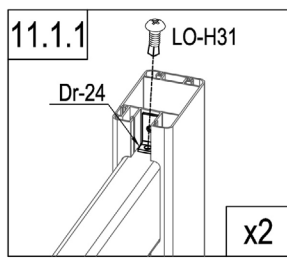
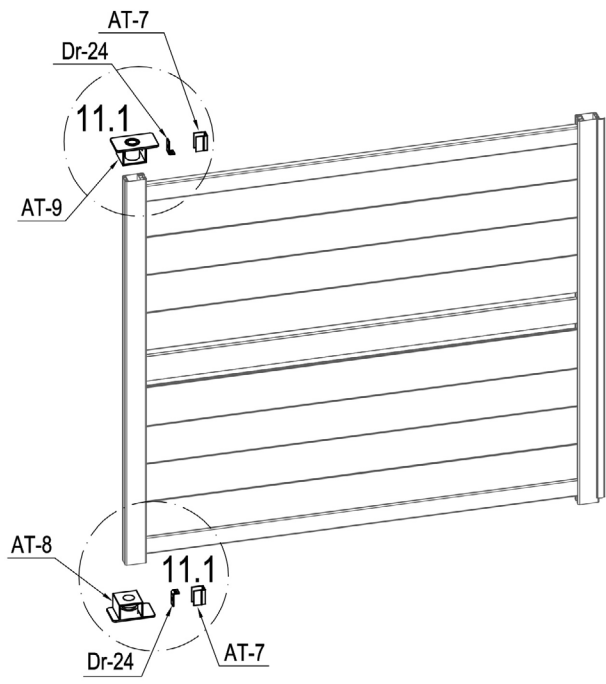

	AT-8	1
	AT-9	1
	Dr-24	2

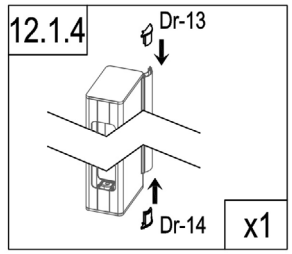
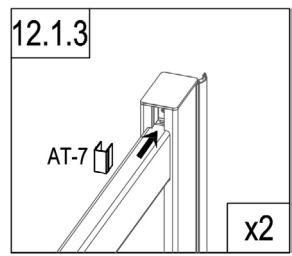
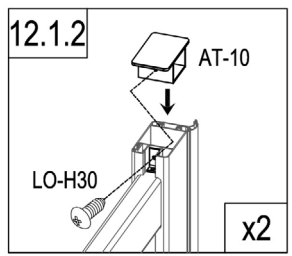
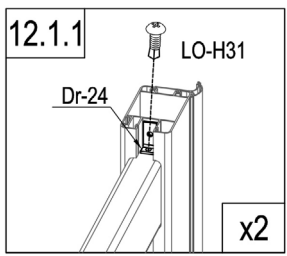
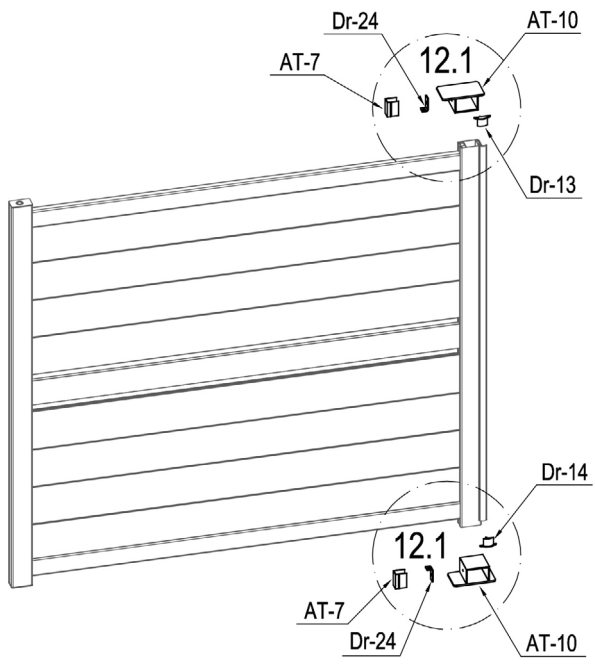

	AT-7	2
	LO-H30	2
	LO-H31	2





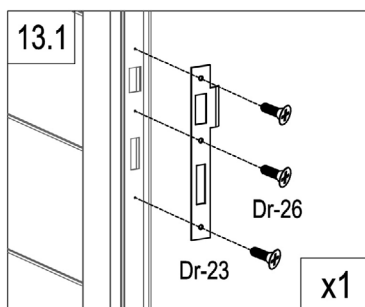
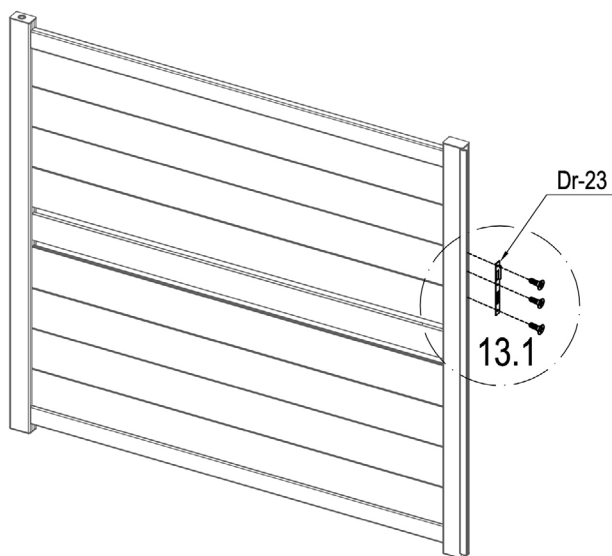

	AT-10	2
	Dr-24	2
	AT-7	2
	Dr-13	1

	Dr-14	1
	LO-H30	2
	LO-H31	2

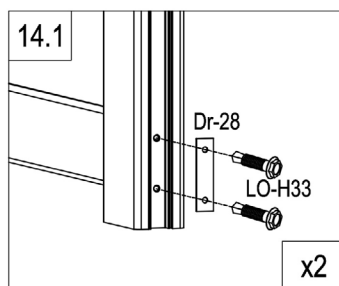
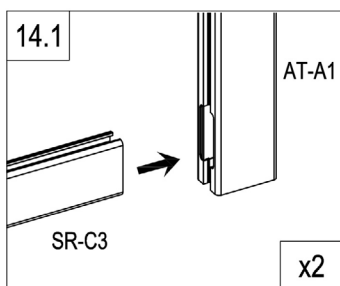
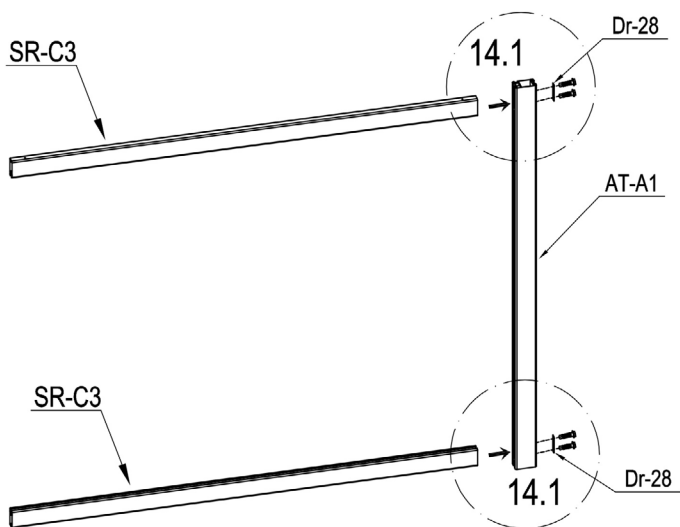

	Dr-23	1
	Dr-26	3



	AT-A1	1
	SR-C3	2
	Dr-28	2
	LO-H33	4

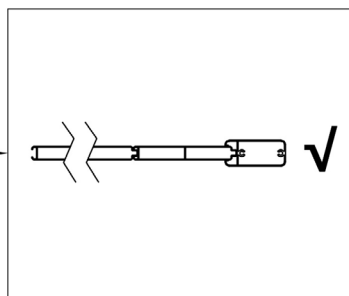
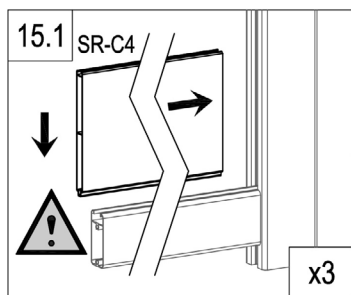
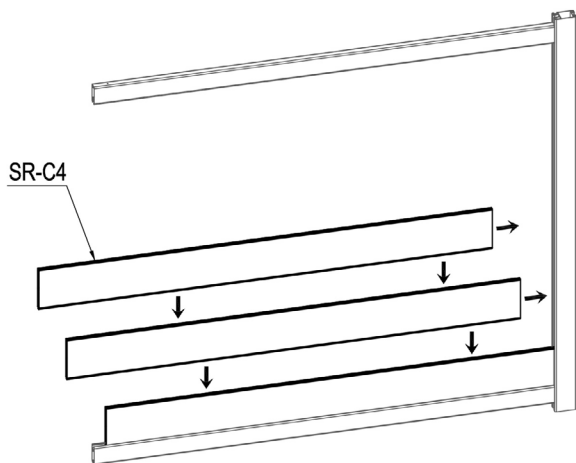

	SR-C4	3
---	-------	---

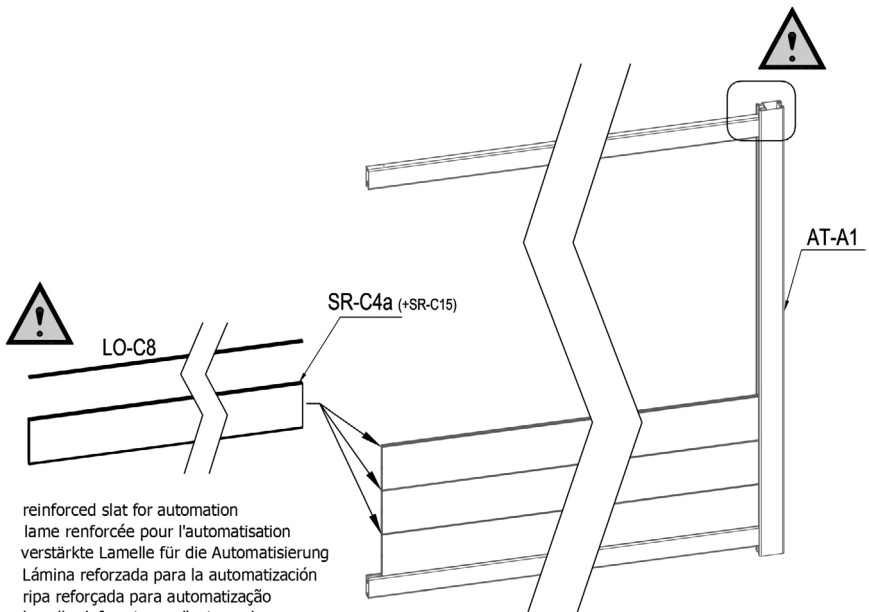

- EN: reinforced slat for automation
- FR: lame renforcée pour l'automatisation
- DE: verstärkte Lamelle für die Automatisierung
- ES: Lámina reforzada para la automatización
- PT: ripa reforçada para automatização
- IT: lamella rinforzata per l'automazione
- NL: versterkte lat voor automatisering
- PL: wzmocniona listwa do automatyzacji

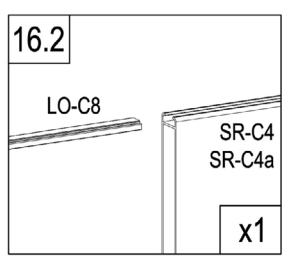
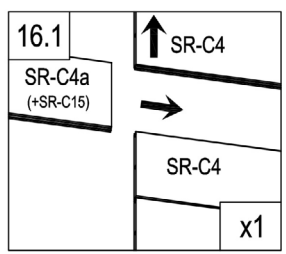
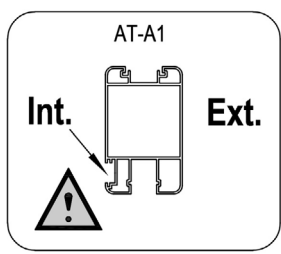
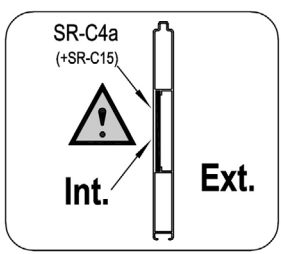

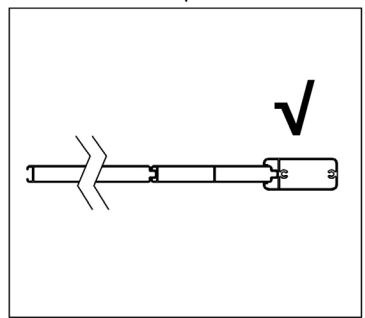
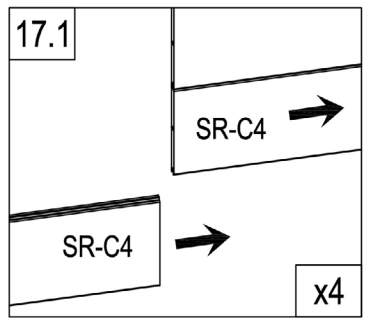
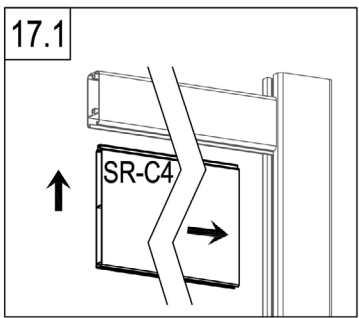
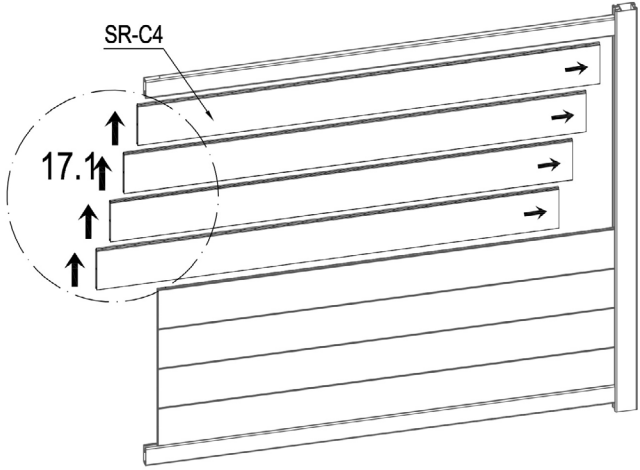

	LO-C8	1
	SR-C4a (+SR-C15)	1



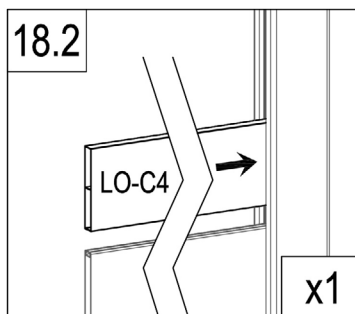
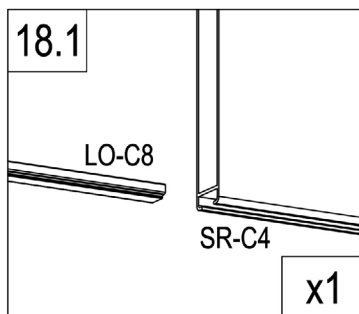
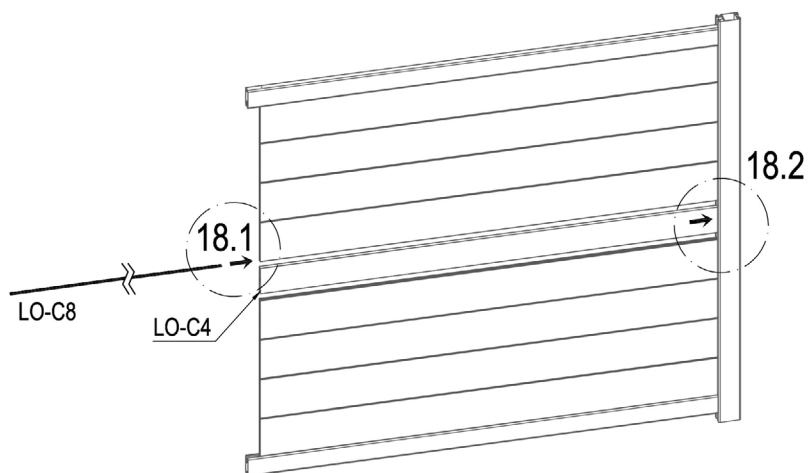

	SR-C4	4
---	-------	---

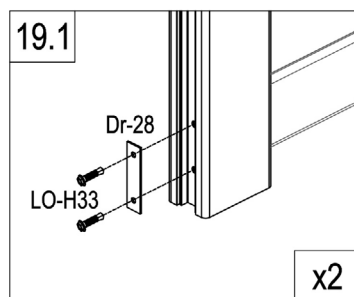
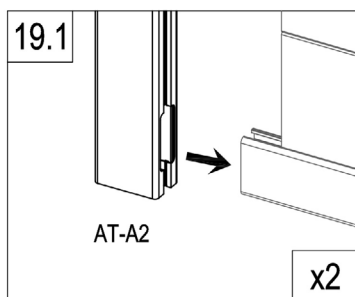
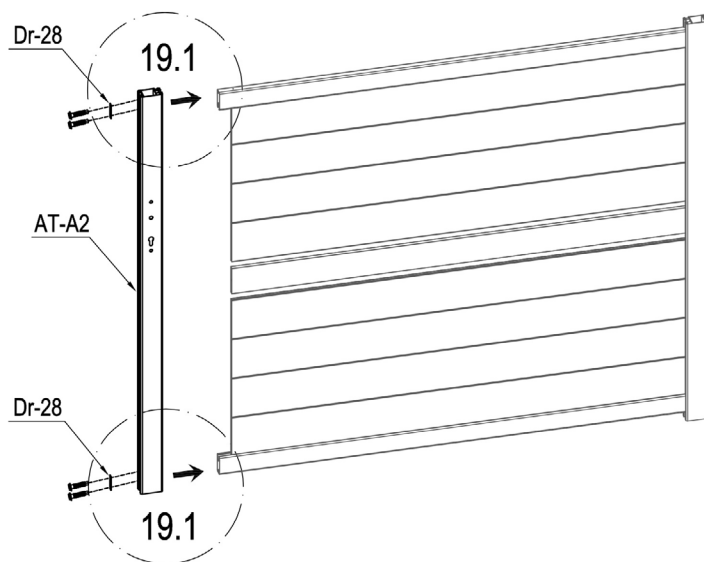

	LO-C4	1
	LO-C8	1



	AT-A2	1
	Dr-28	2
	LO-H33	4

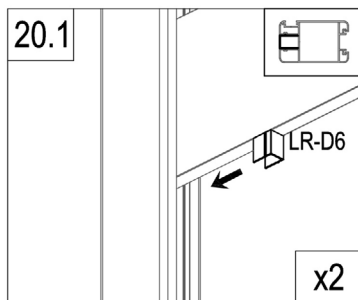
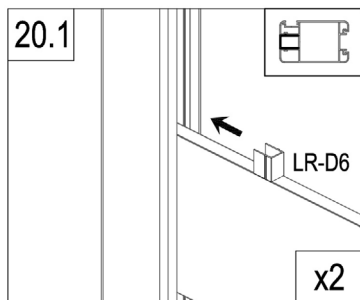
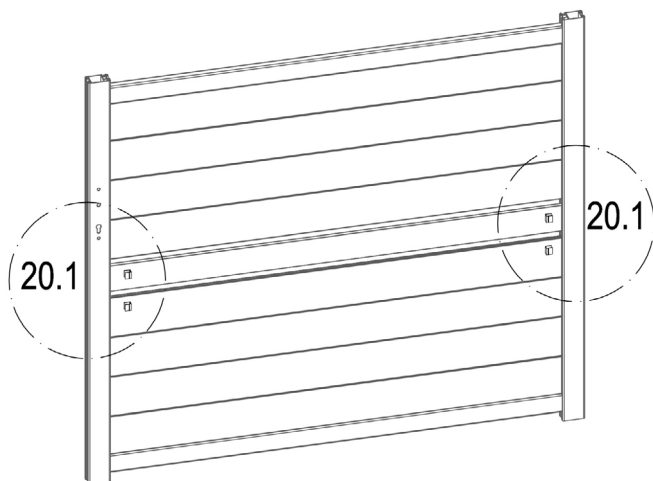

	LR-D6	4
---	-------	---

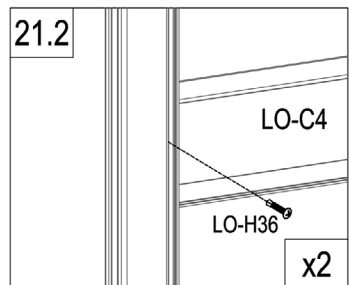
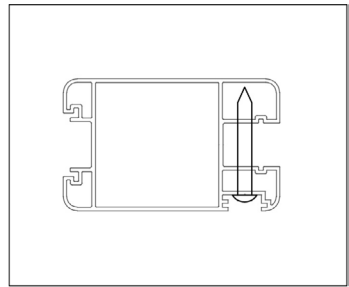
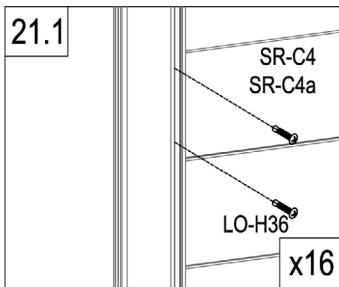
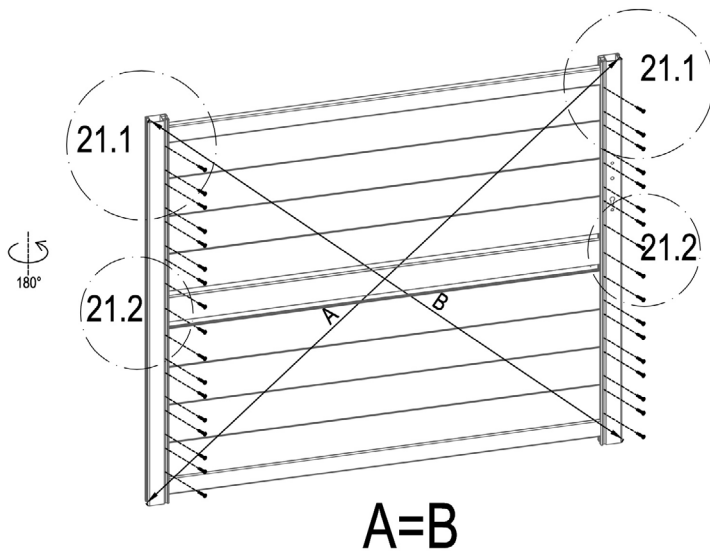

	LO-H36	34
---	--------	----

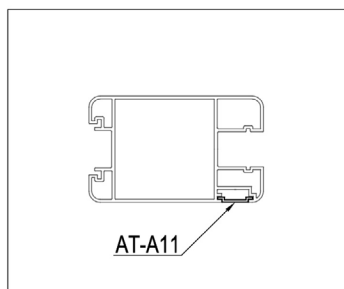
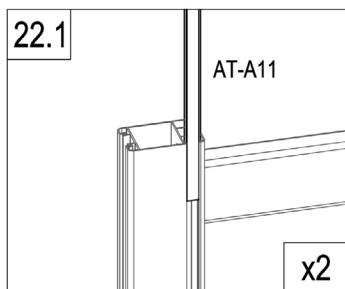
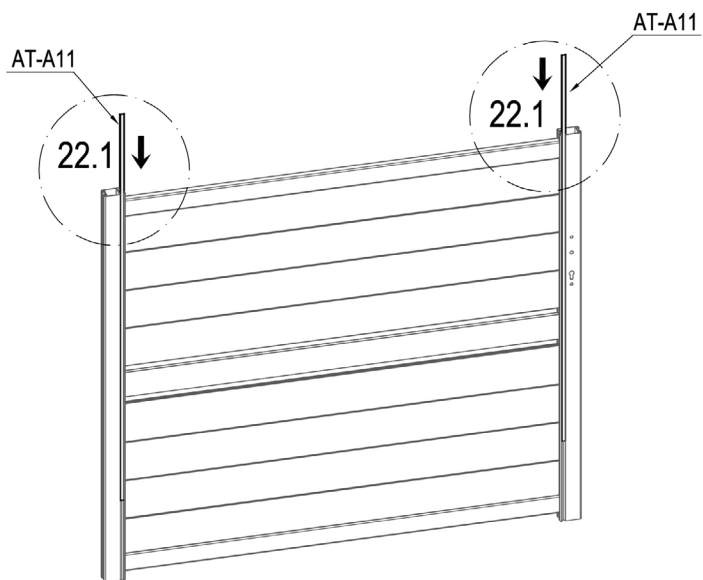

	AT-A11	2
---	--------	---

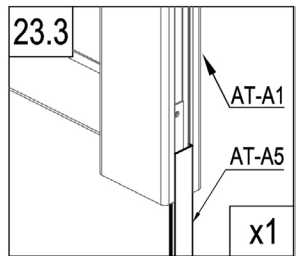
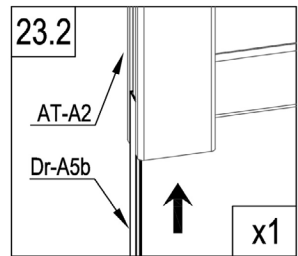
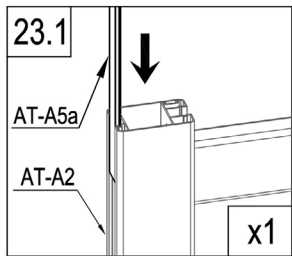
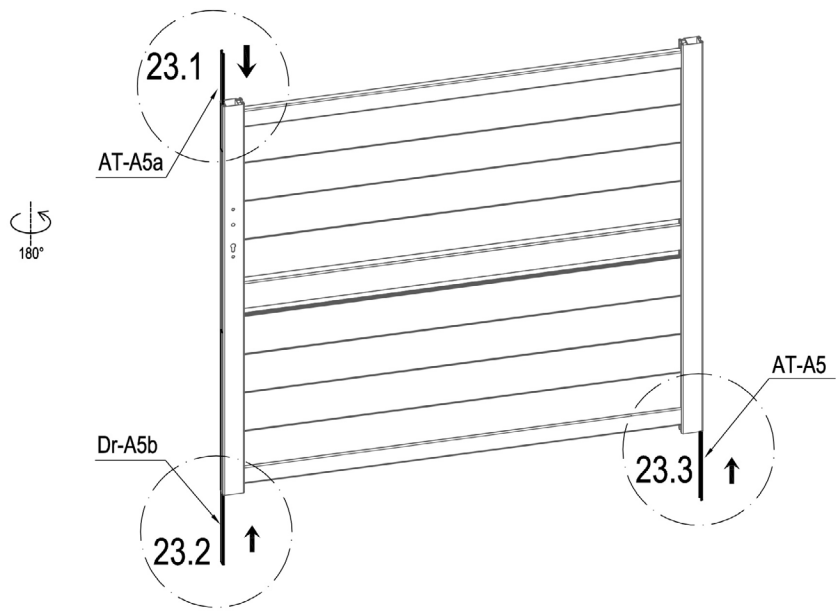

	AT-A5	1
	AT-A5a	1
	Dr-A5b	1

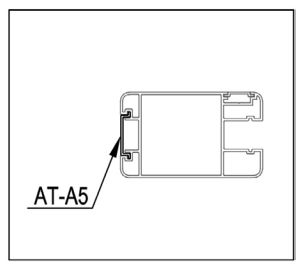

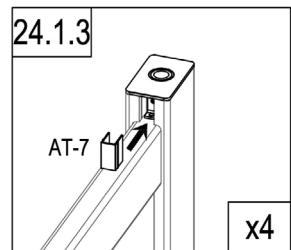
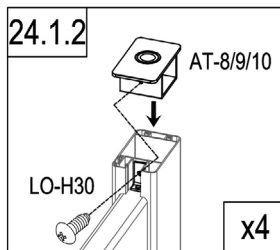
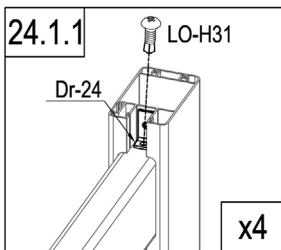
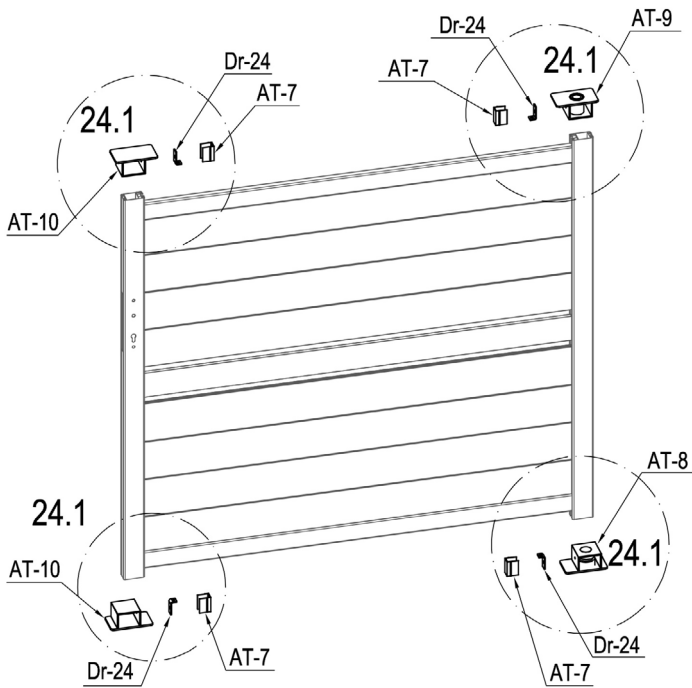

	AT-8	1
	AT-9	1
	AT-10	2
	Dr-24	4

	AT-7	4
	LO-H30	4
	LO-H31	4

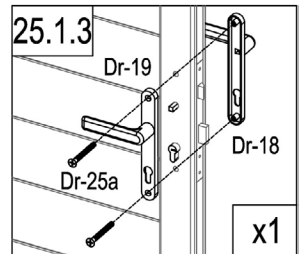
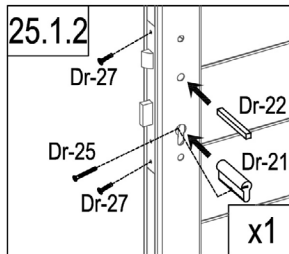
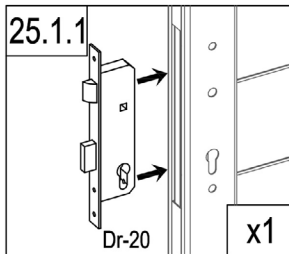
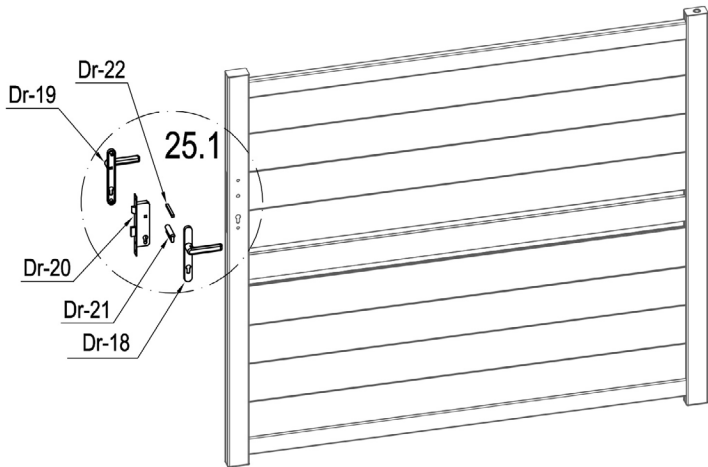

	Dr-20	1
	Dr-21	1
	Dr-22	1
	Dr-25	1

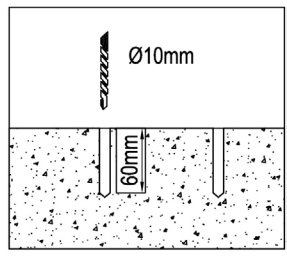
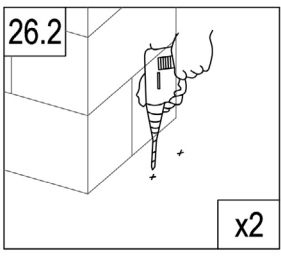
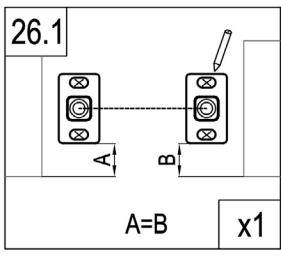
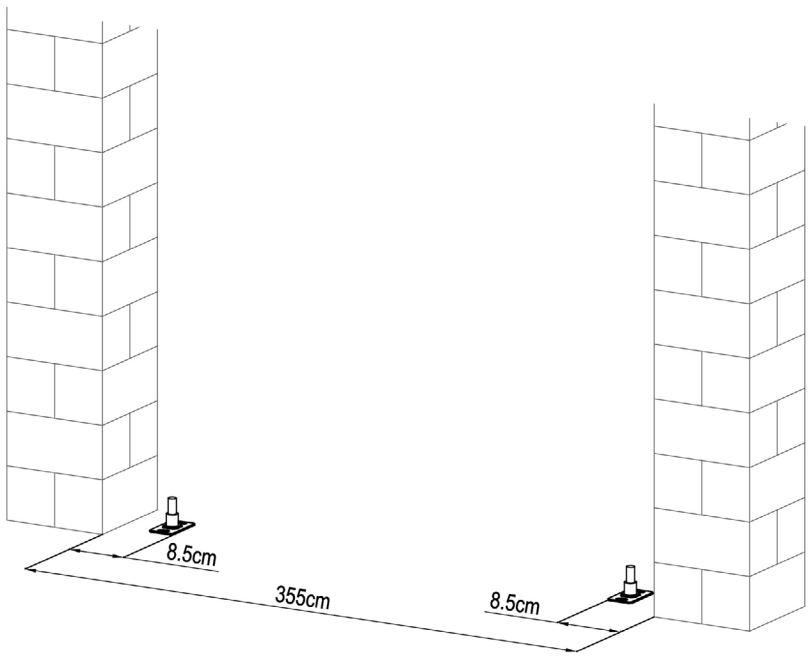

	Dr-18	1
	Dr-19	1
	Dr-25a	2
	Dr-27	2



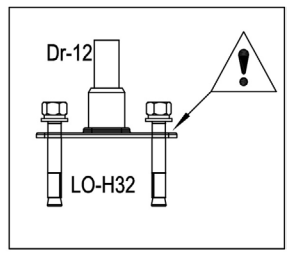
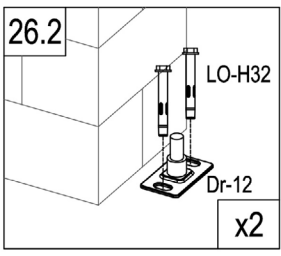

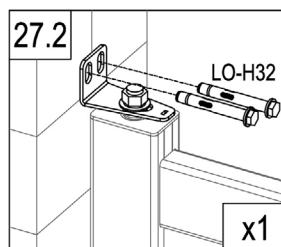
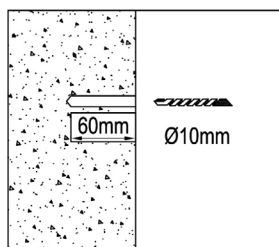
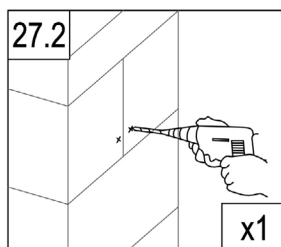
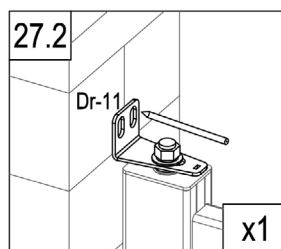
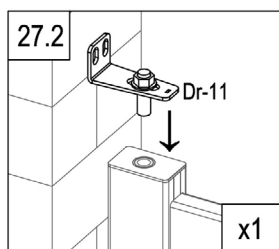
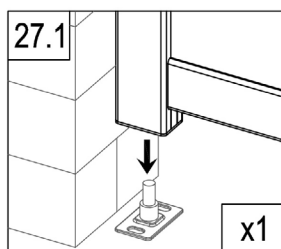
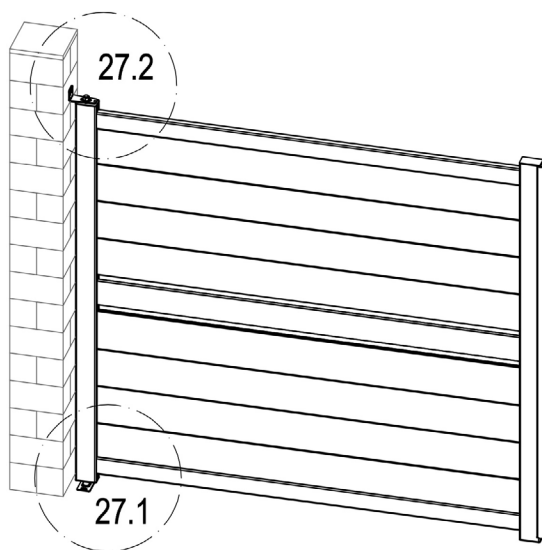
	Dr-12	2
	LO-H32	4





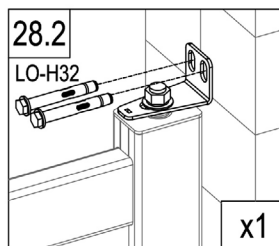
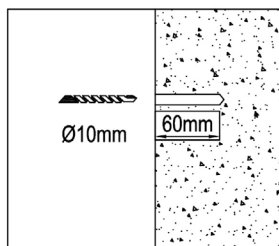
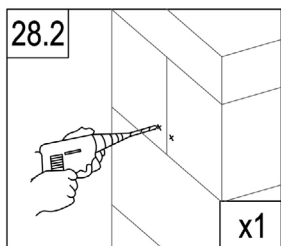
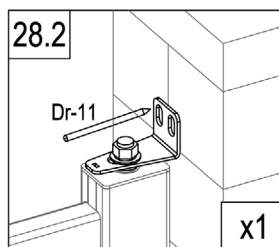
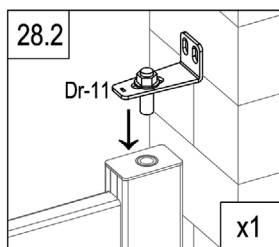
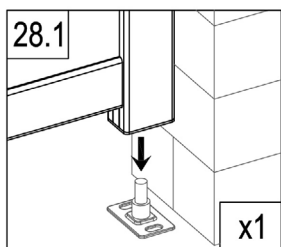
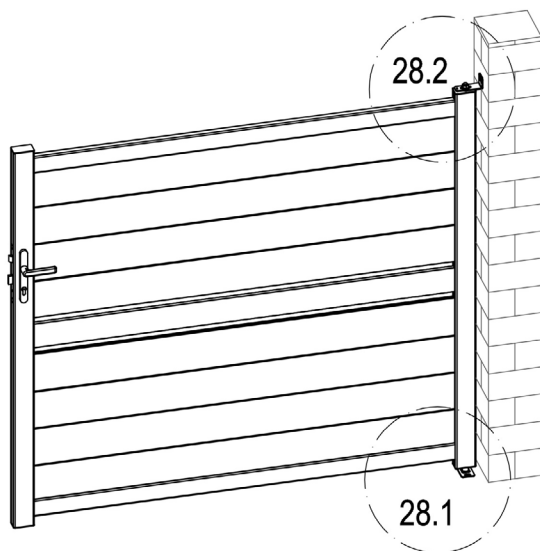

	Dr-11	1
	LO-H32	2



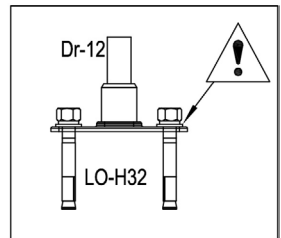
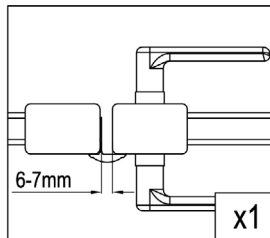
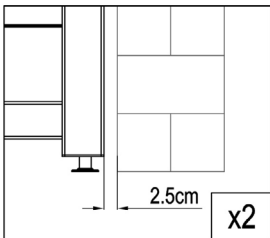
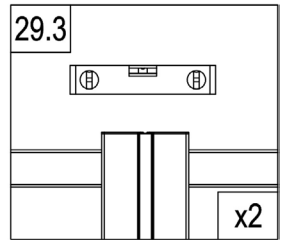
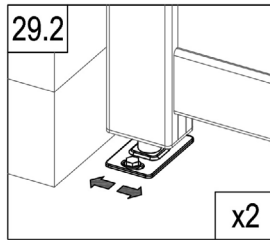
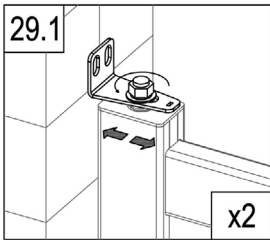
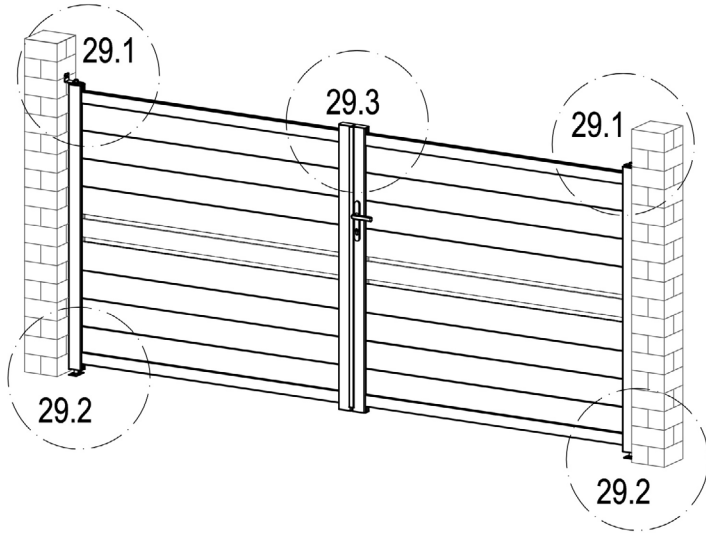

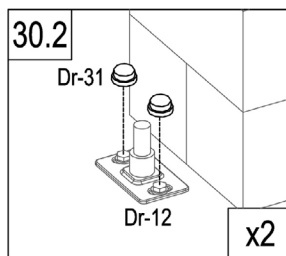
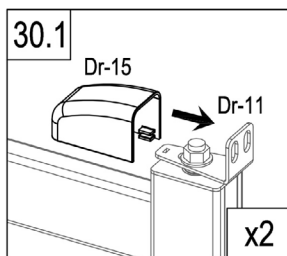
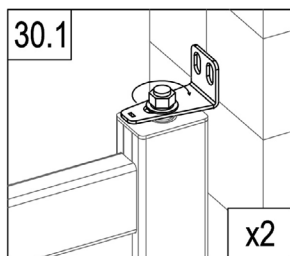
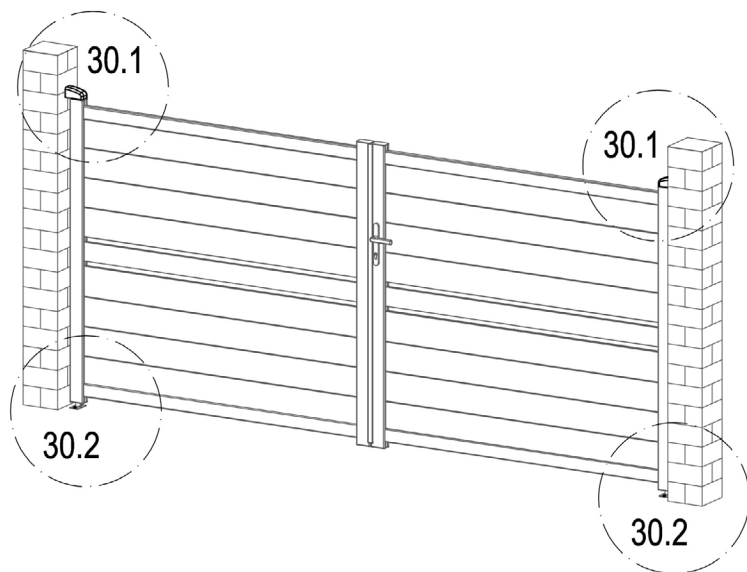

	Dr-11	1
	LO-H32	2



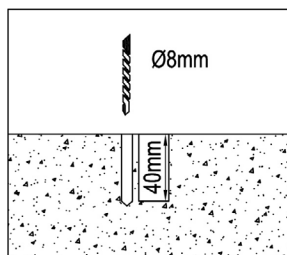
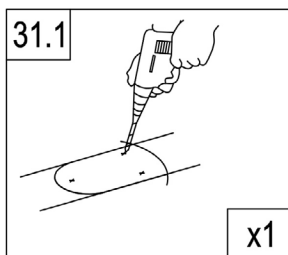
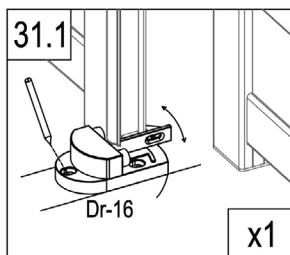
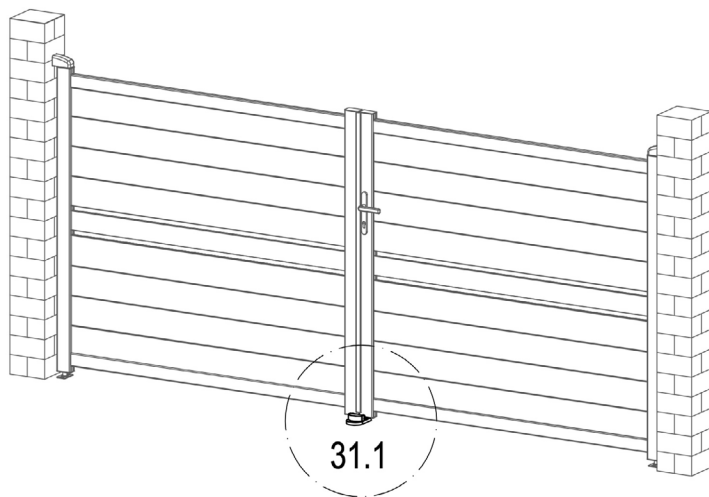



	Dr-15	2
	Dr-31	4

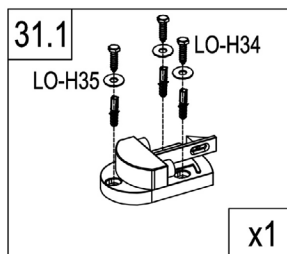

	Dr-16	1
	LO-H34	3
	LO-H35	3

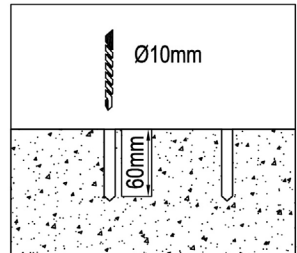
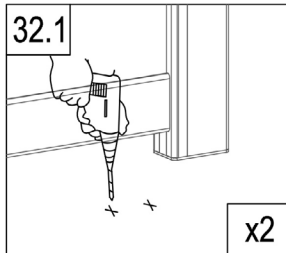
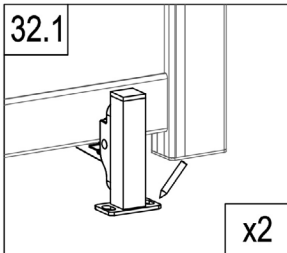
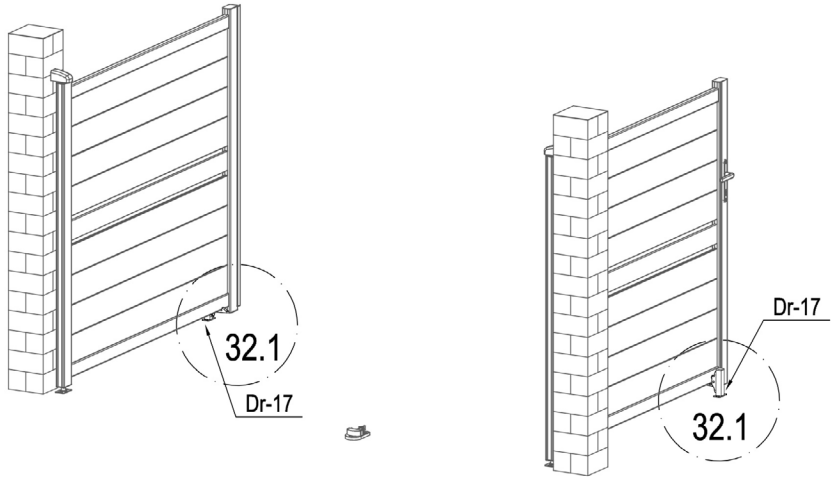



	LO-H32	4
	Dr-17	2

