

CASANOVO

CIMONE 300B140

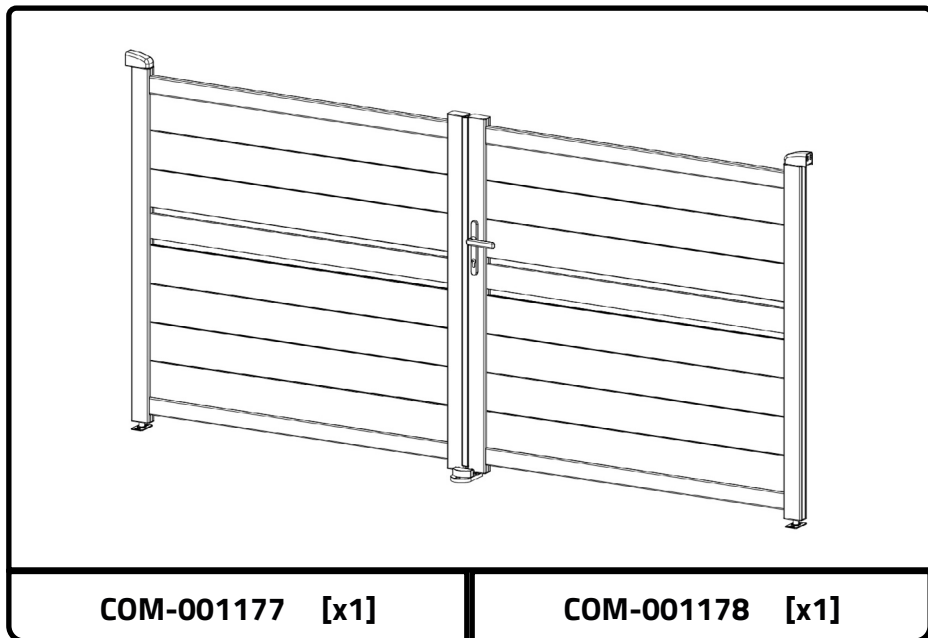

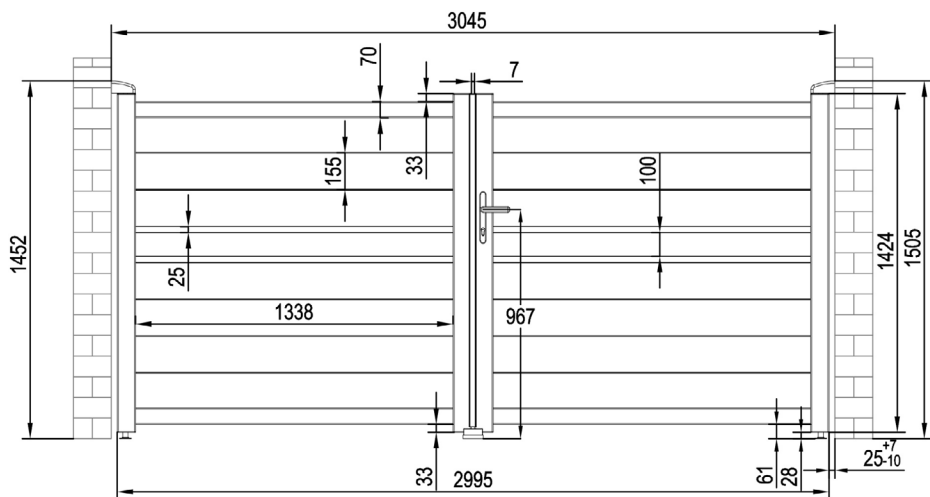



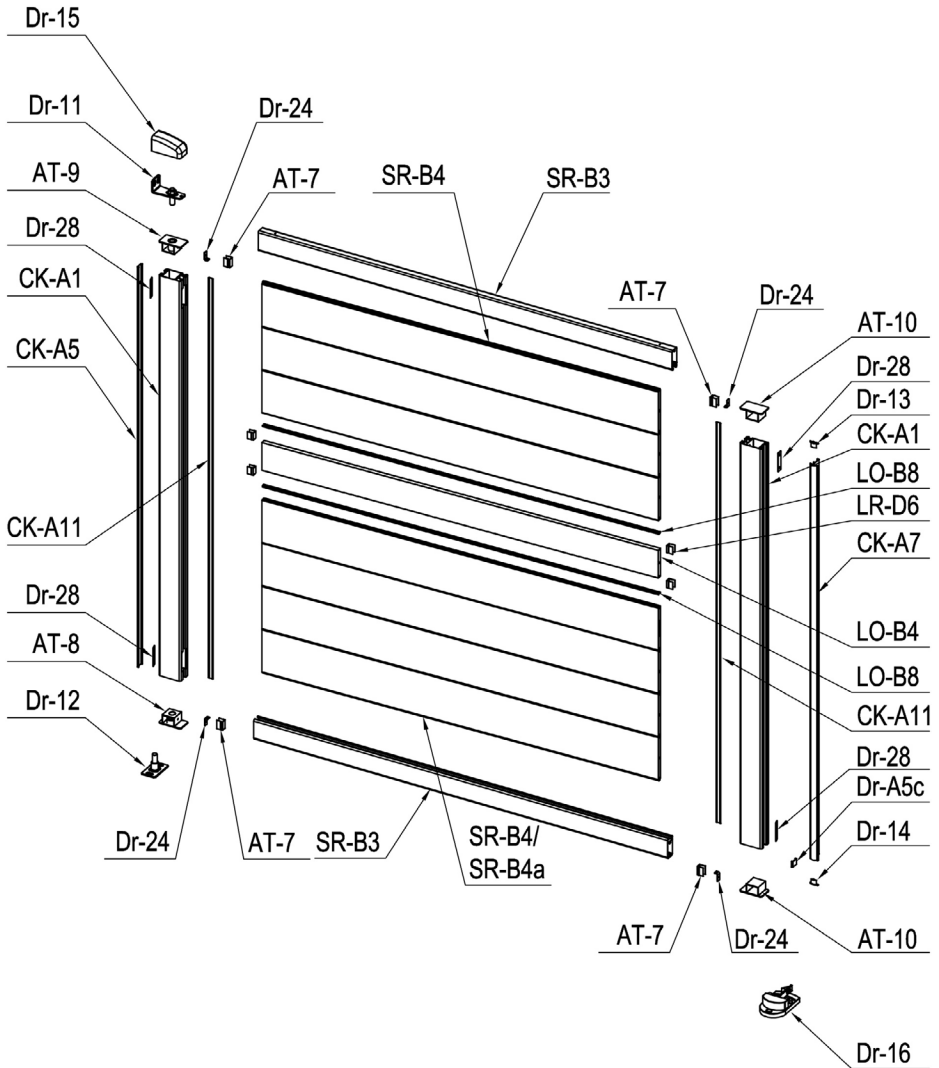

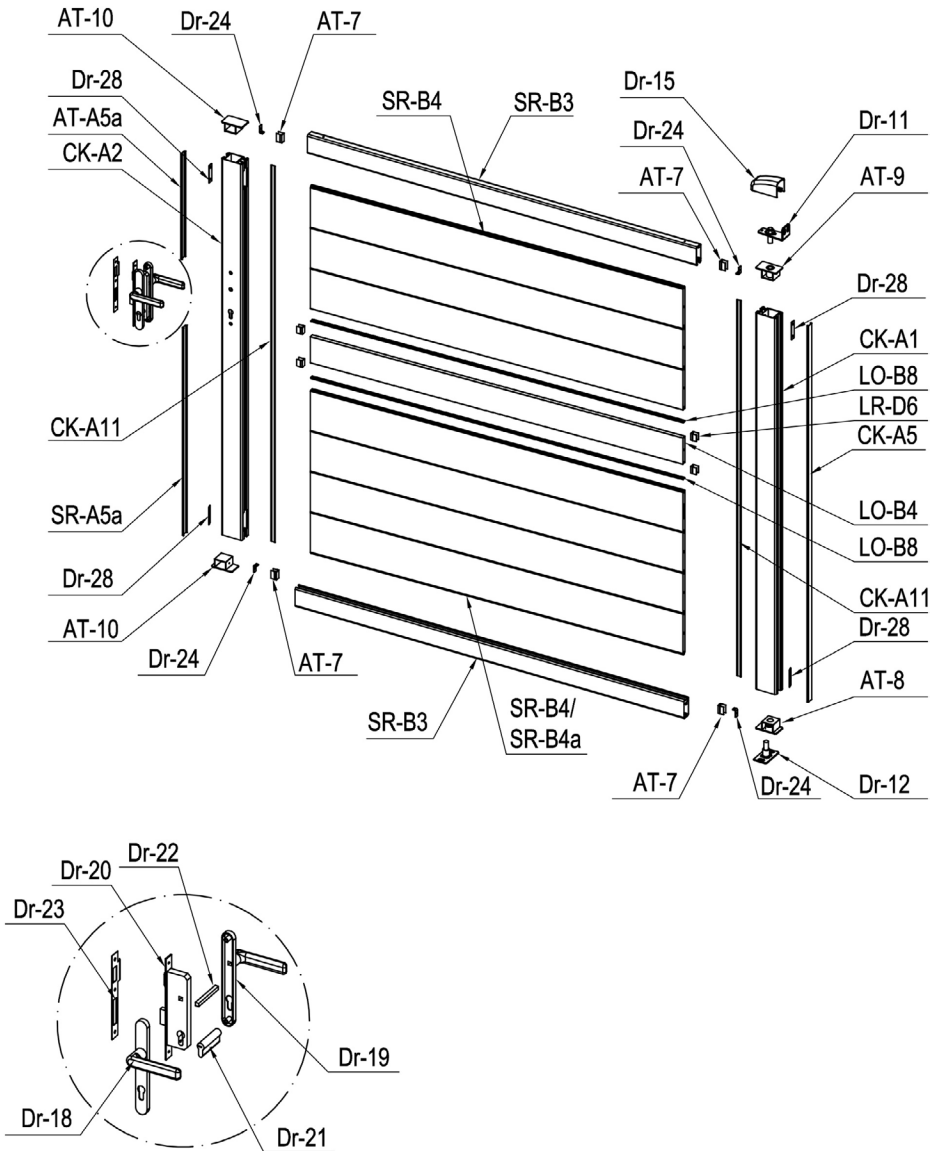































INSTRUCTION MANUAL / NOTICE DE MONTAGE / MONTAGEANLEITUNG / MANUAL DE MONTAJE / MANUAL DE MONTAGEM / MANUALE DI MONTAGGIO /
MONTAGEHANDLEIDING / INSTRUKCJA MONTAŻU / KÄYTTÖOHJEET / BRUKSANVISNING / BRUGSANVISNING / INSTRUCIUNI DE ASAMBLARE /
NAVODILA ZA SESTAVLJANJE / NÁVOD NA MONTÁŽ / ÖSSZESZERELÉSI ÚTMUTATÓ / NÁVOD K MONTÁŽI / UPUTE ZA INSTALACIJU /
ΟΔΗΓΙΕΣ ΣΥΝΑΡΜΟΛΟΓΗΣΗΣ / SURINKIMO INSTRUKCIJOS / MONTĀŽAS INSTRUKCIJAS







CASANOVA

| IMAGE | NO. | L.(mm) | QTY | IMAGE | NO. | L.(mm) | QTY |
|---|---------------------|--------|-----|---|--------|----------|-----|
|  | CK-A1 | 1418 | 3 |  | Dr-15 | | 2 |
| | CK-A2 | 1418 | 1 |  | Dr-16 | | 1 |
|  | SR-B3 | 1471 | 4 |  | Dr-17 | | 2 |
|  | SR-B4a (+SR-B15) | 1380 | 2 |  | Dr-31 | | 4 |
|  | SR-B4 | 1380 | 12 |  | Dr-18 | | 1 |
|  | LO-B4 | 1380 | 2 |  | Dr-19 | | 1 |
|  | CK-A5 | 1418 | 2 |  | Dr-21 | | 1 |
| | AT-A5a | 395.5 | 1 |  | Dr-22 | | 1 |
| | SR-A5a | 782 | 1 |  | Dr-23 | | 1 |
| | Dr-A5c | 19.5 | 1 |  | Dr-25 | | 1 |
|  | CK-A11 | 1418 | 4 |  | Dr-25a | | 2 |
|  | AT-7 | 29.5 | 8 |  | Dr-26 | | 3 |
| | LR-D6 | 25 | 8 |  | Dr-27 | | 2 |
|  | LO-B8 | 1379 | 4 |  | Dr-24 | | 8 |
|  | CK-A7 | 1398 | 1 |  | Dr-28 | | 8 |
|  | AT-8 | | 2 |  | LO-D30 | ST4x10 | 8 |
|  | AT-9 | | 2 |  | LO-D31 | ST4.2x13 | 8 |
|  | AT-10 | | 4 |  | LO-D32 | M8x60 | 12 |
|  | Dr-11 | | 2 |  | LO-D33 | ST5.5x38 | 16 |
|  | Dr-12 | | 2 |  | LO-D34 | ST6x40 | 3 |
|  | Dr-13 | | 1 |  | LO-D35 | ∅6 | 3 |
|  | Dr-14 | | 1 |  | LO-D36 | ST4.8x38 | 60 |

CASANOVO

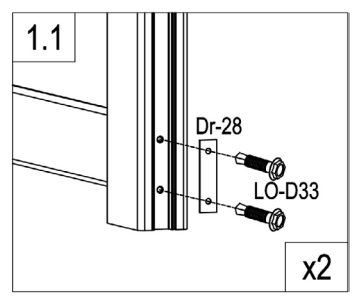
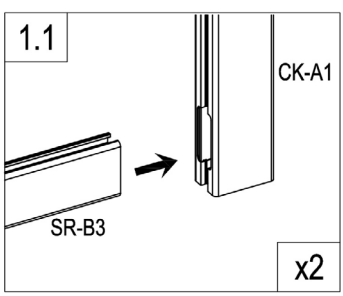
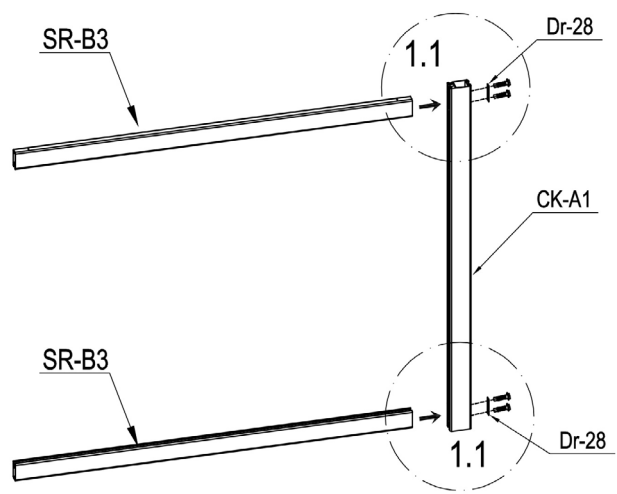

| | | |
|--|--------|---|
| | CK-A1 | 1 |
| | SR-B3 | 2 |
| | Dr-28 | 2 |
| | LO-D33 | 4 |

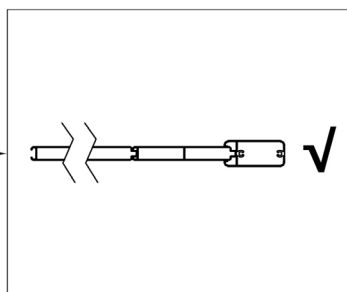
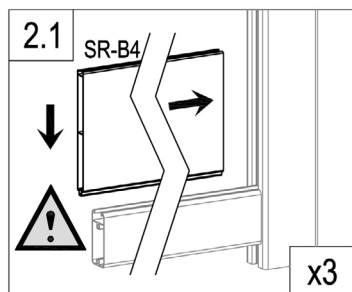
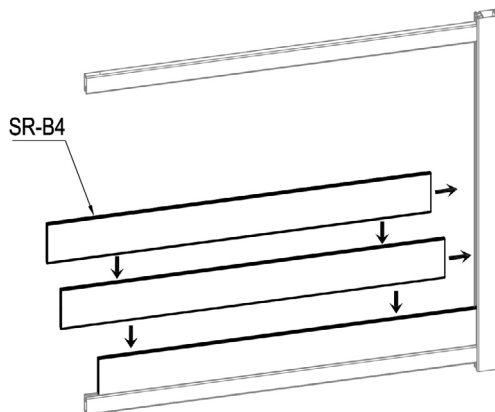

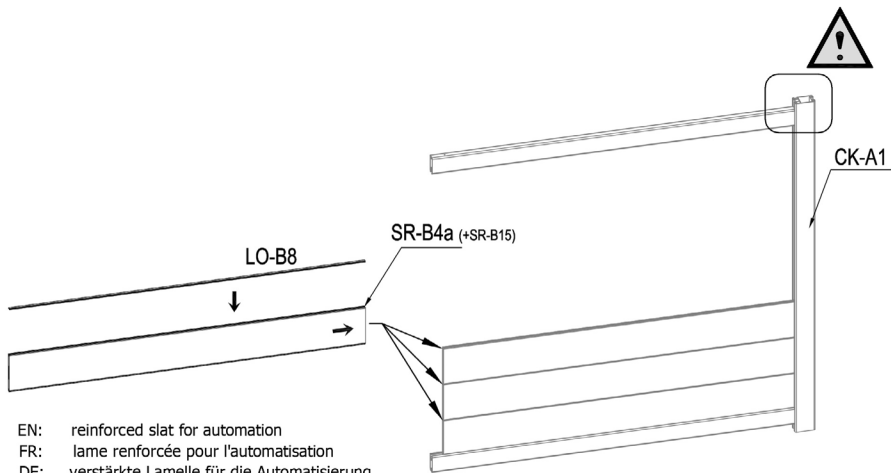

| | | |
|---|-------|---|
|  | SR-B4 | 3 |
|---|-------|---|

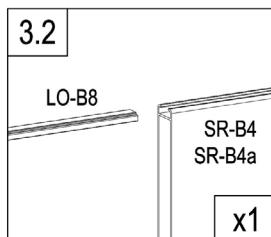
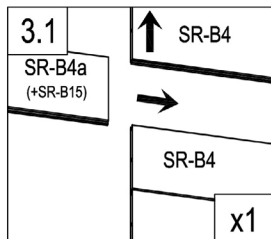
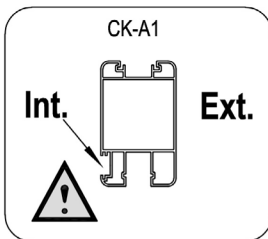
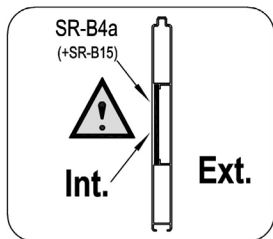

- EN: reinforced slat for automation
- FR: lame renforcée pour l'automatisation
- DE: verstärkte Lamelle für die Automatisierung
- ES: Lámina reforzada para la automatización
- PT: ripa reforçada para automatização
- IT: lamella rinforzata per l'automazione
- NL: versterkte lat voor automatisering
- PL: wzmocniona listwa do automatyzacji



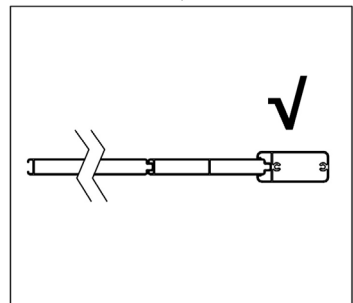
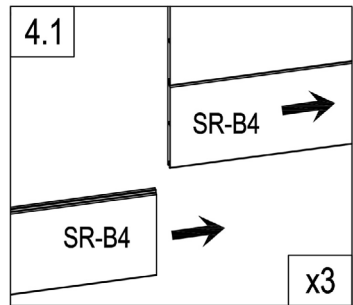
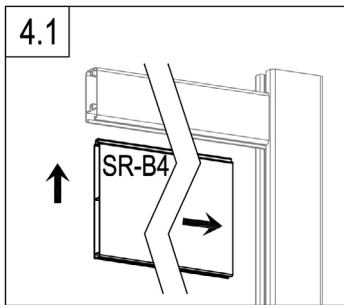
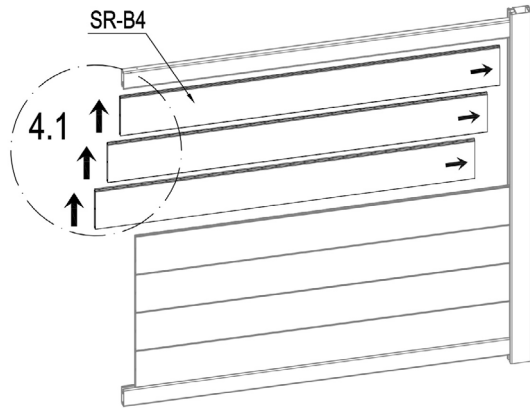

| | | |
|---|------------------|---|
|  | LO-B8 | 1 |
|  | SR-B4a (+SR-B15) | 1 |



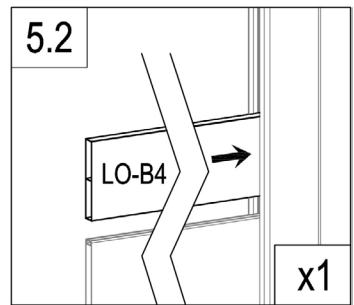
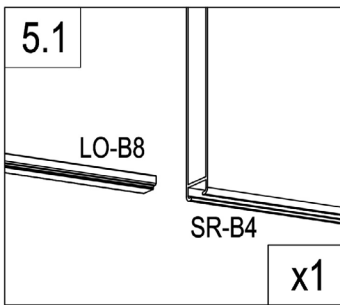
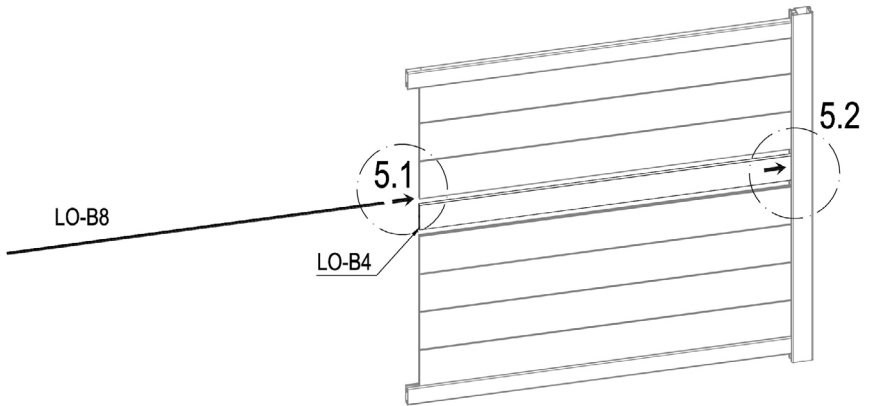

| | | |
|---|-------|---|
|  | SR-B4 | 3 |
|---|-------|---|

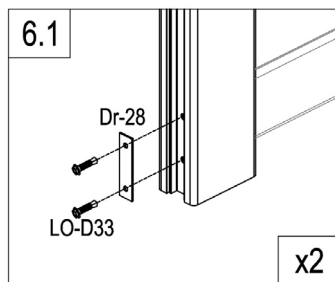
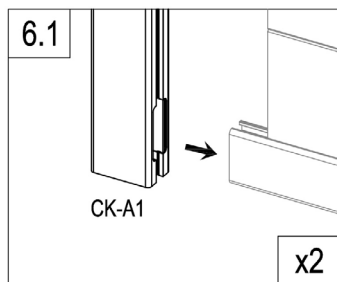
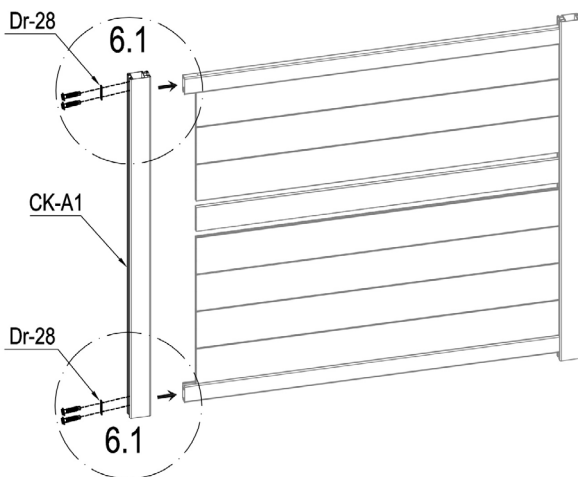

| | | |
|---|-------|---|
|  | LO-B4 | 1 |
|  | LO-B8 | 1 |



| | | |
|---|--------|---|
|  | CK-A1 | 1 |
|  | Dr-28 | 2 |
|  | LO-D33 | 4 |

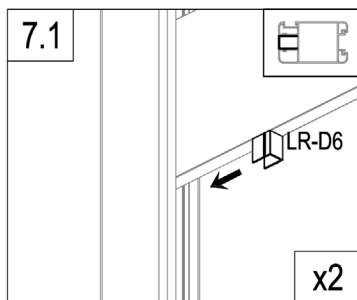
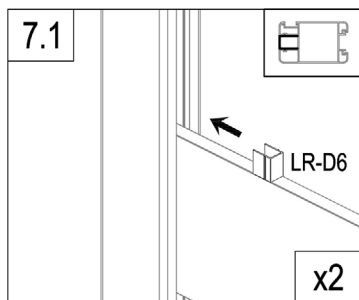
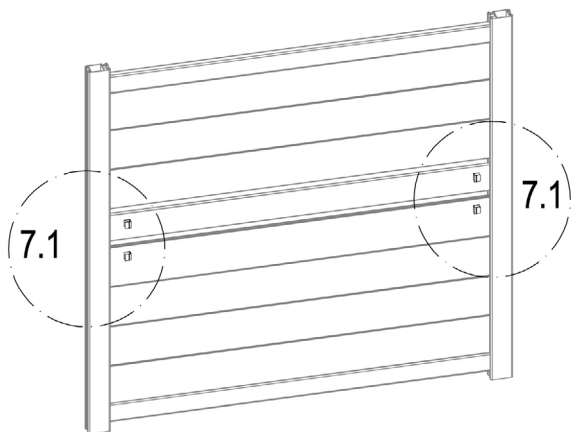

| | | |
|---|-------|---|
|  | LR-D6 | 4 |
|---|-------|---|

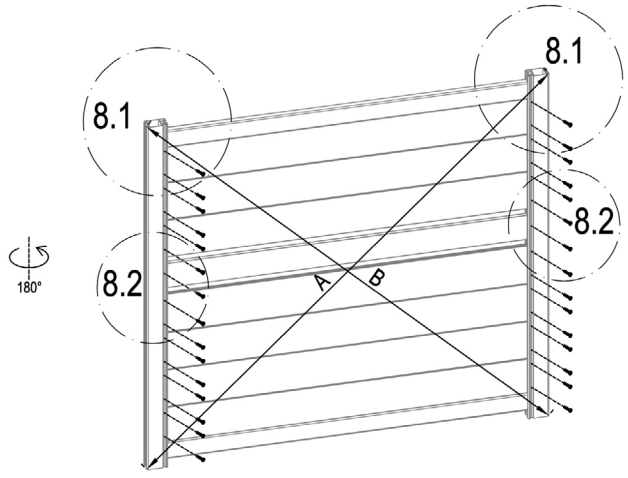

A=B

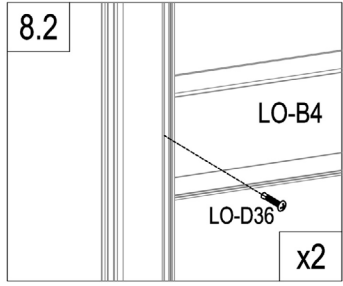
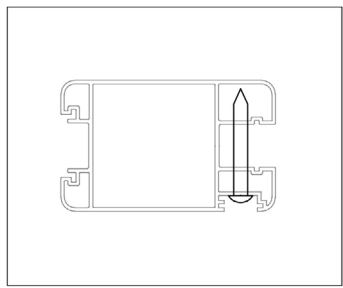
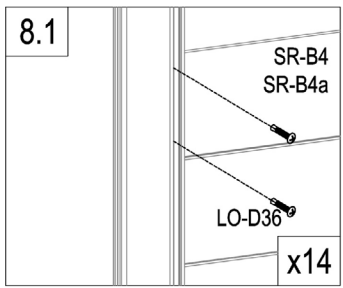

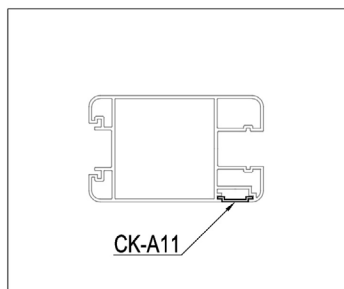
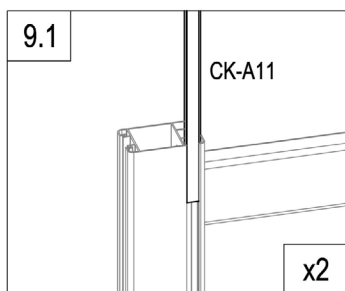
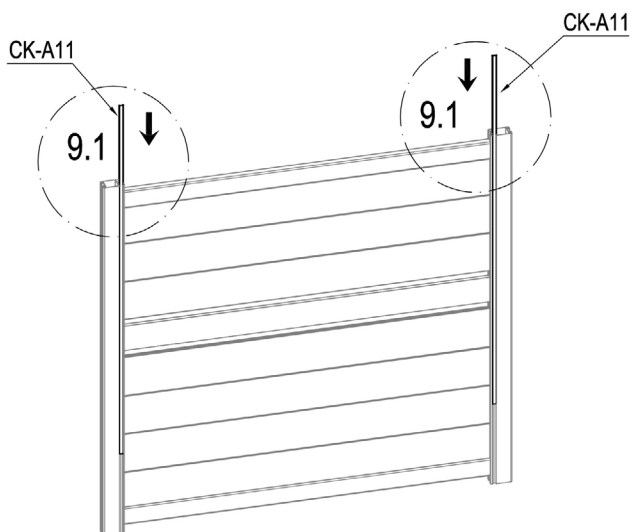

| | | |
|---|--------|----|
|  | LO-D36 | 30 |
|---|--------|----|

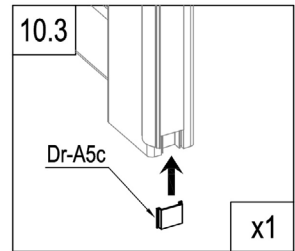
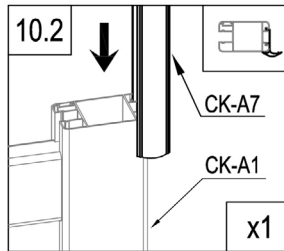
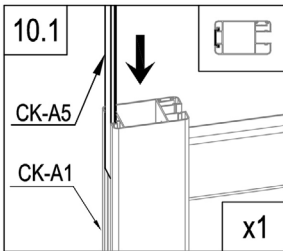
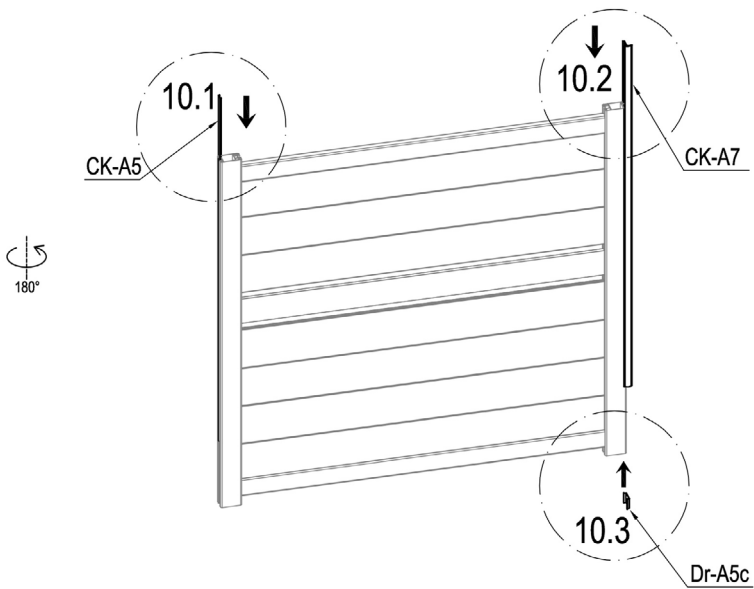

| | | |
|---|--------|---|
|  | CK-A11 | 2 |
|---|--------|---|



| | | |
|---|--------|---|
|  | CK-A5 | 1 |
| | Dr-A5c | 1 |
|  | CK-A7 | 1 |

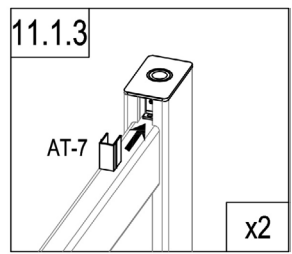
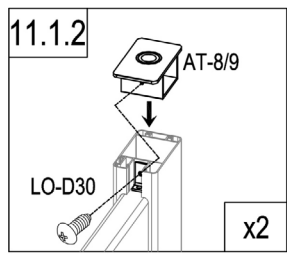
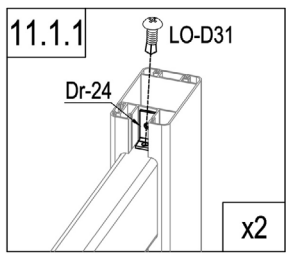
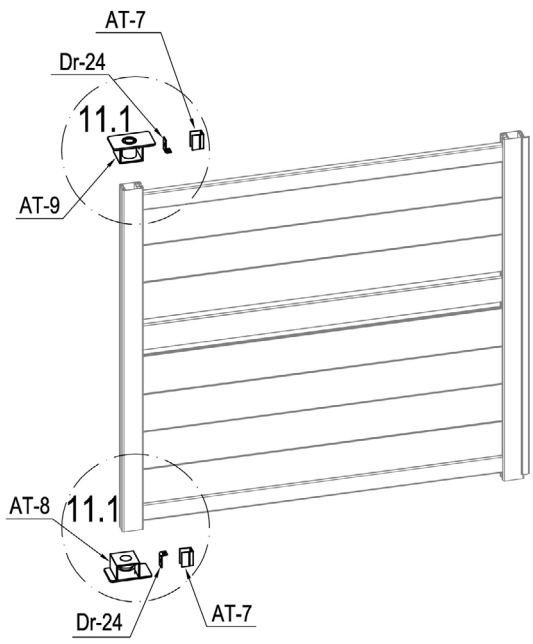

| | | |
|--|-------|---|
| | AT-8 | 1 |
| | AT-9 | 1 |
| | Dr-24 | 2 |

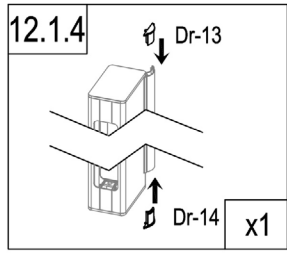
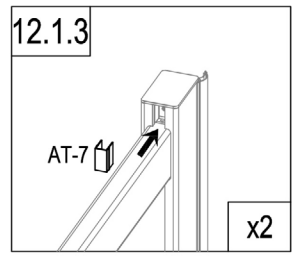
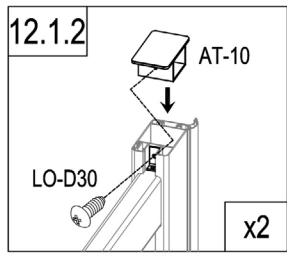
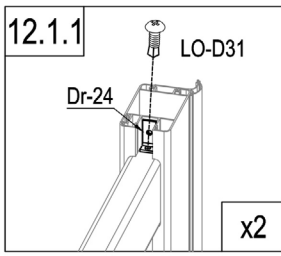
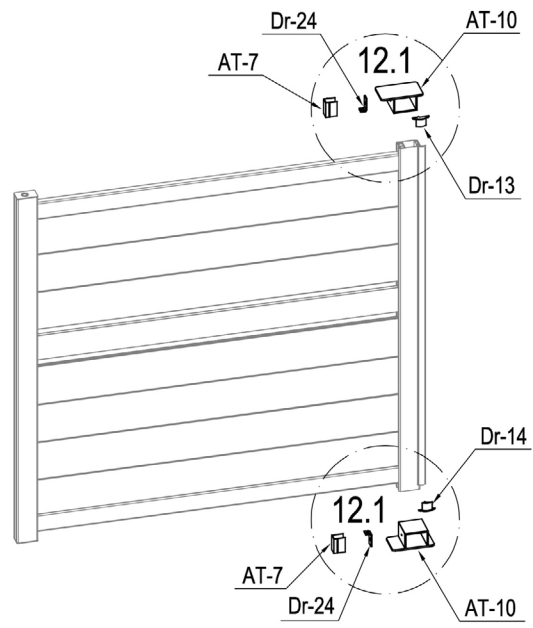

| | | |
|--|--------|---|
| | AT-7 | 2 |
| | LO-D30 | 2 |
| | LO-D31 | 2 |

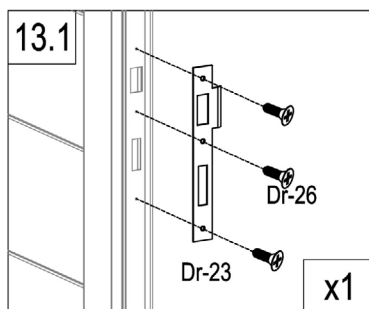
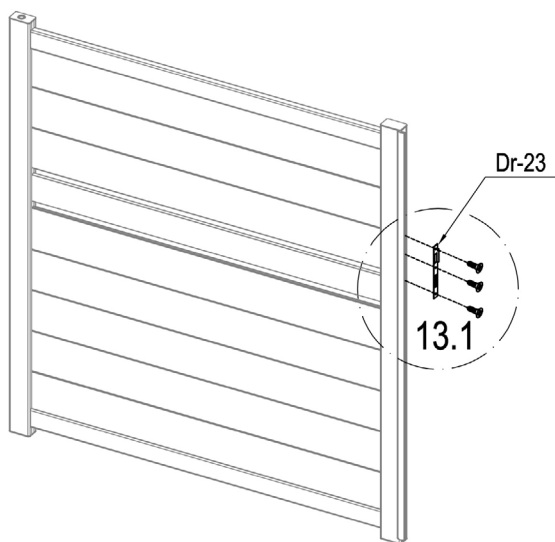

| | | |
|--|-------|---|
| | AT-10 | 2 |
| | Dr-24 | 2 |
| | AT-7 | 2 |
| | Dr-13 | 1 |

| | | |
|--|--------|---|
| | Dr-14 | 1 |
| | LO-D30 | 2 |
| | LO-D31 | 2 |



| | | |
|---|-------|---|
|  | Dr-23 | 1 |
|  | Dr-26 | 3 |

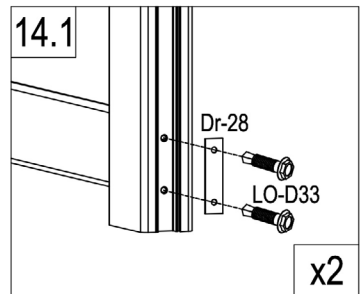
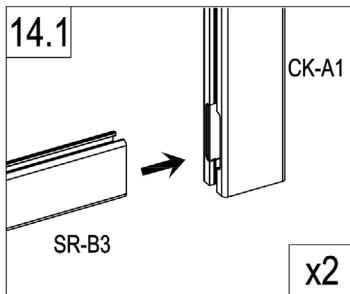
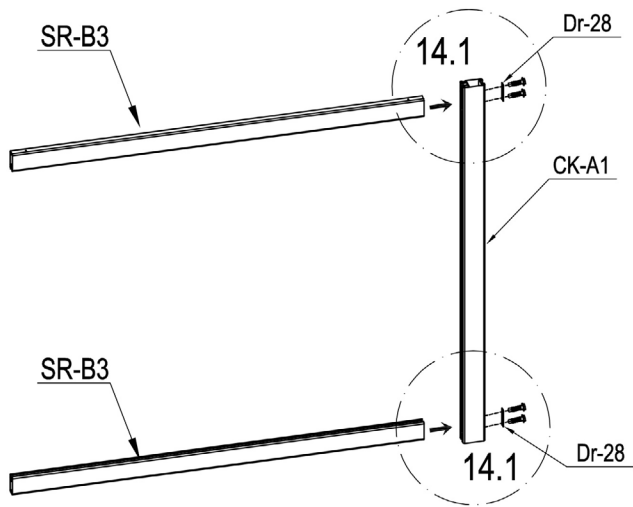

| | | |
|--|--------|---|
| | CK-A1 | 1 |
| | SR-B3 | 2 |
| | Dr-28 | 2 |
| | LO-D33 | 4 |

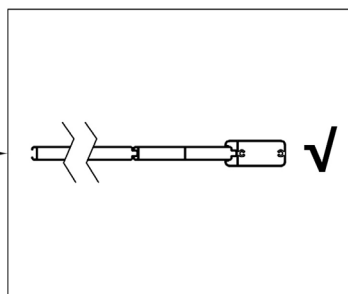
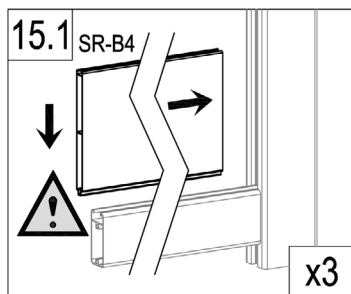
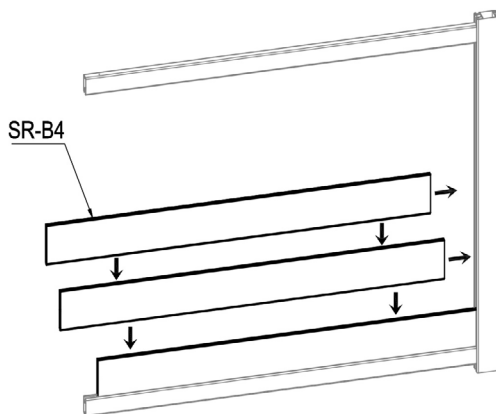

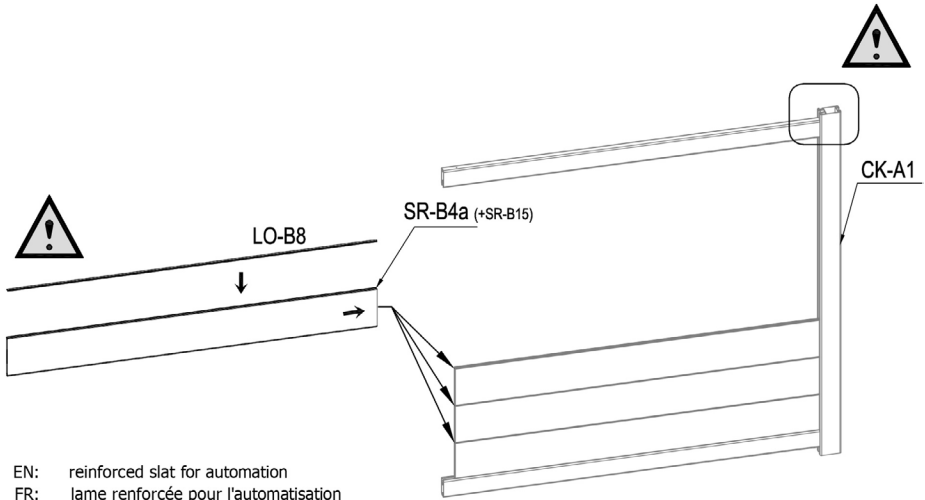

| | | |
|---|-------|---|
|  | SR-B4 | 3 |
|---|-------|---|

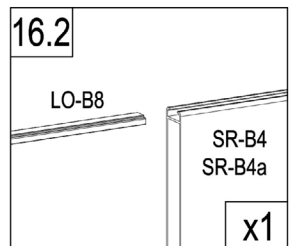
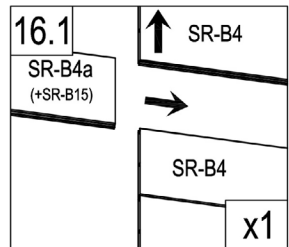
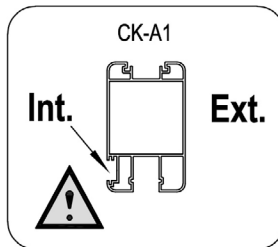
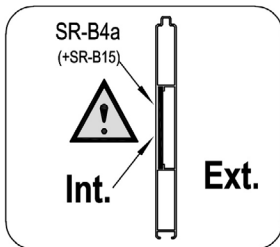

- EN: reinforced slat for automation
 FR: lame renforcée pour l'automatisation
 DE: verstärkte Lamelle für die Automatisierung
 ES: Lámina reforzada para la automatización
 PT: ripa reforçada para automatização
 IT: lamella rinforzata per l'automazione
 NL: versterkte lat voor automatisering
 PL: wzmocniona listwa do automatyzacji



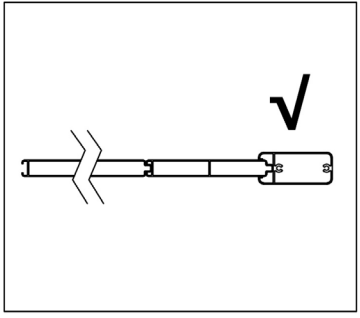
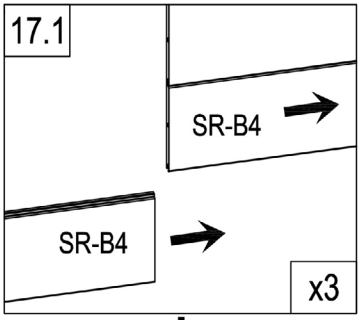
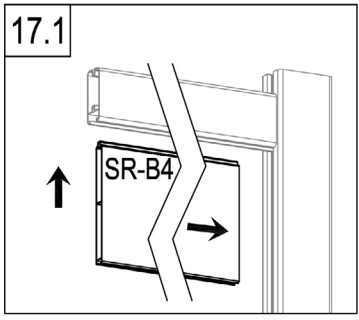
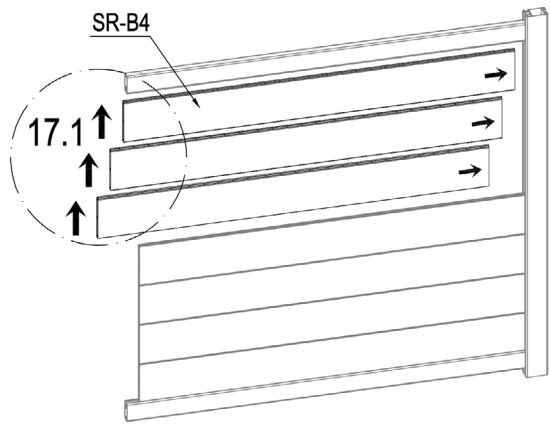

| | | |
|---|------------------|---|
|  | LO-B8 | 1 |
|  | SR-B4a (+SR-B15) | 1 |



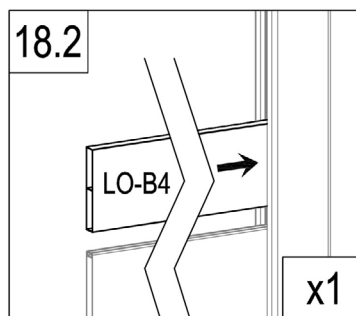
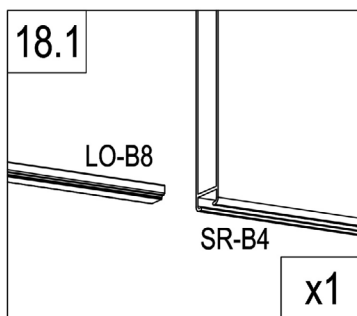
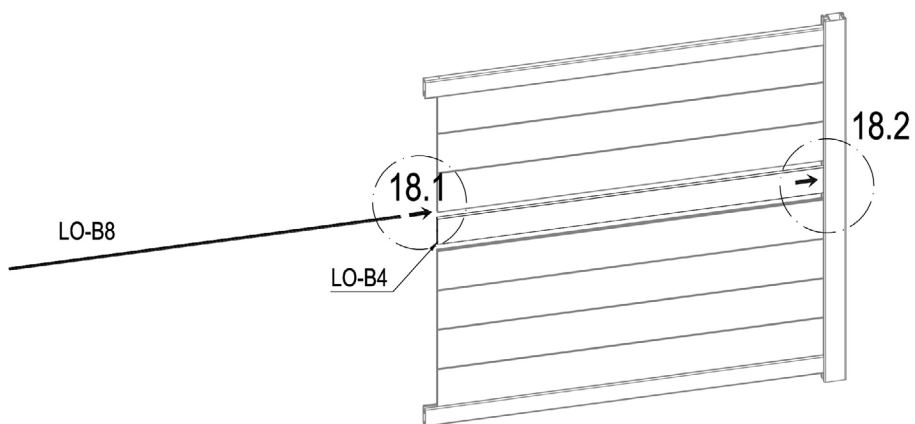

| | | |
|---|-------|---|
|  | SR-B4 | 3 |
|---|-------|---|

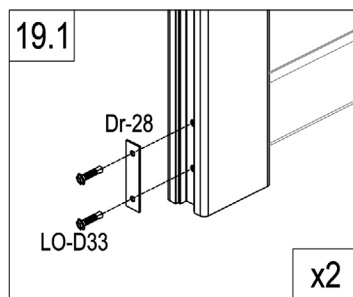
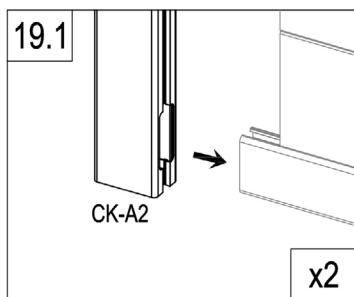
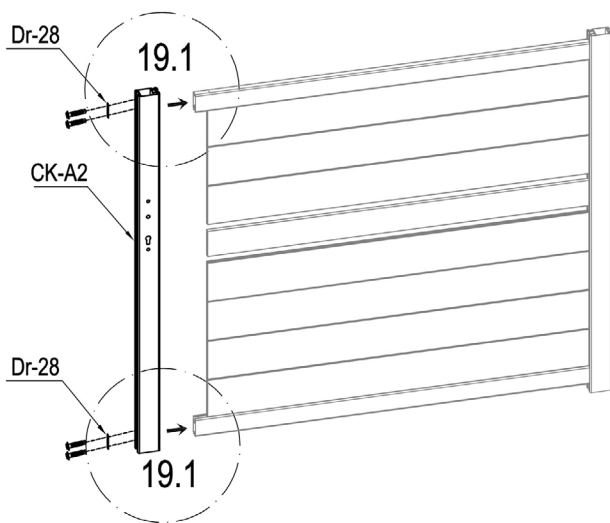

| | | |
|---|-------|---|
|  | LO-B4 | 1 |
|  | LO-B8 | 1 |



| | | |
|---|--------|---|
|  | CK-A2 | 1 |
|  | Dr-28 | 2 |
|  | LO-D33 | 4 |

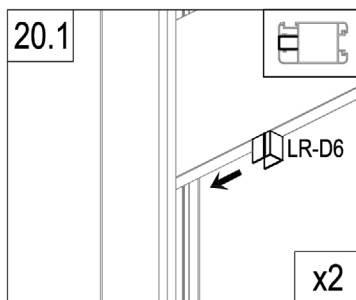
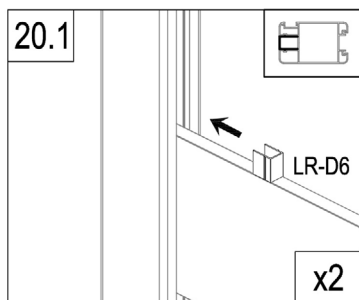
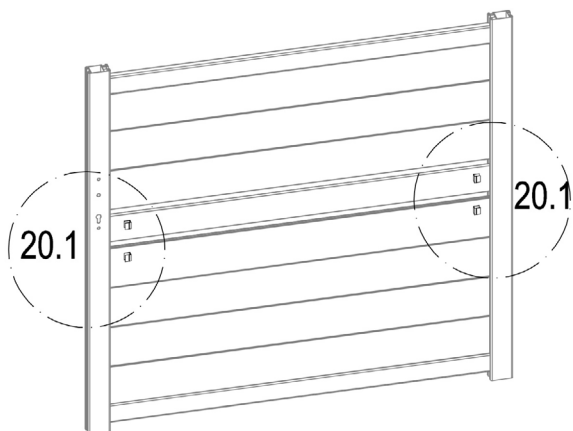

| | | |
|---|-------|---|
|  | LR-D6 | 4 |
|---|-------|---|

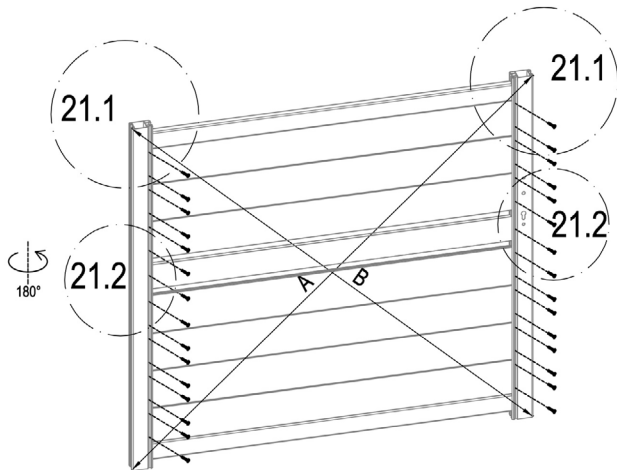

A=B

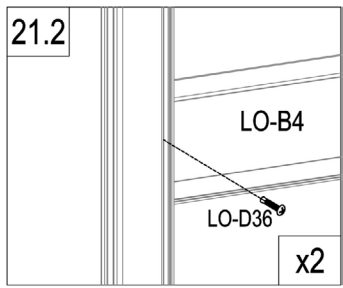
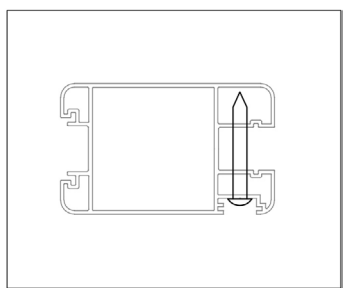
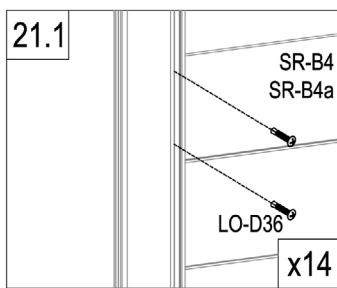

| | | |
|---|--------|----|
|  | LO-D36 | 30 |
|---|--------|----|

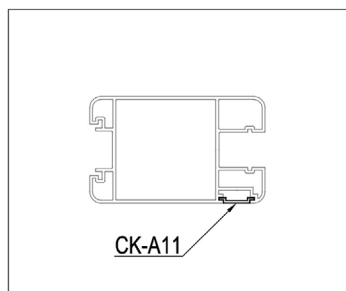
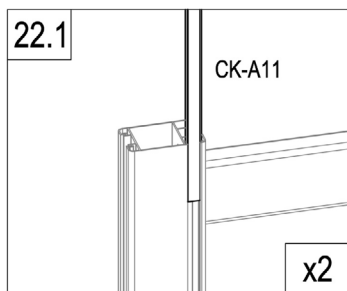
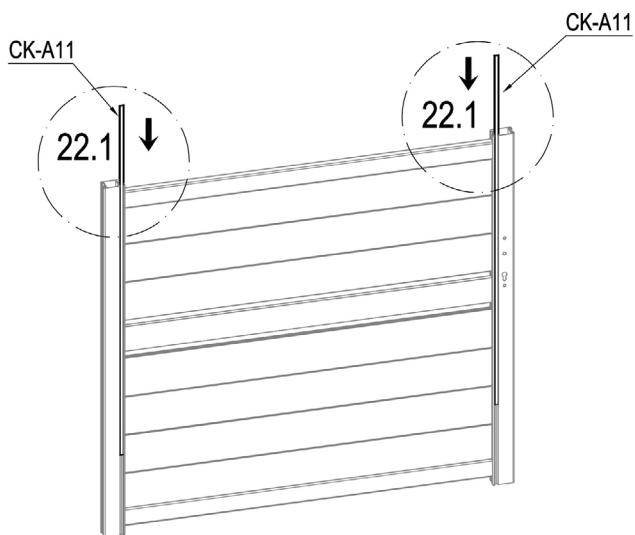

| | | |
|---|--------|---|
|  | CK-A11 | 2 |
|---|--------|---|

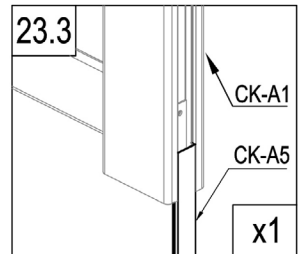
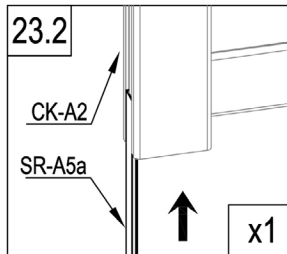
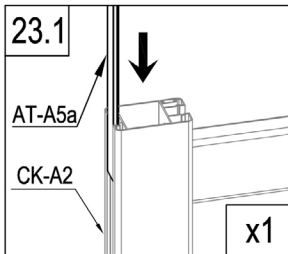
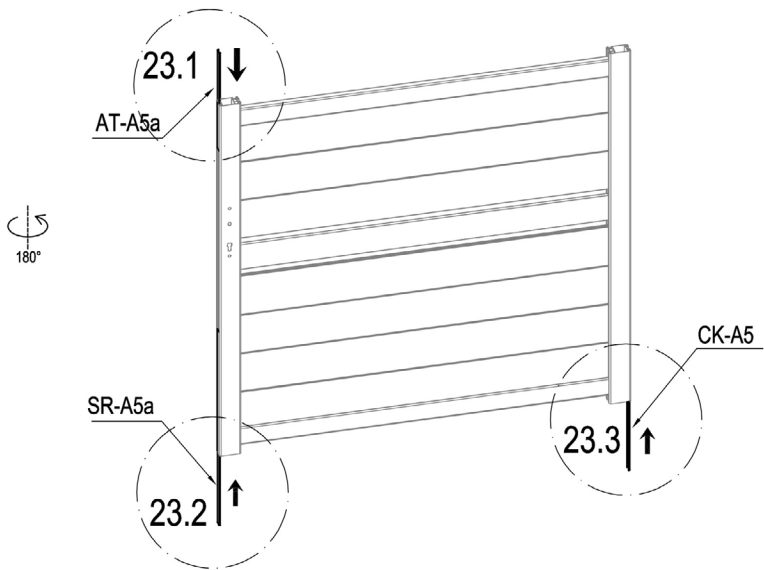

| | | |
|--|--------|---|
| | CK-A5 | 1 |
| | AT-A5a | 1 |
| | SR-A5a | 1 |

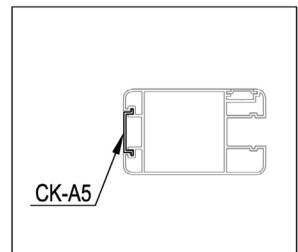

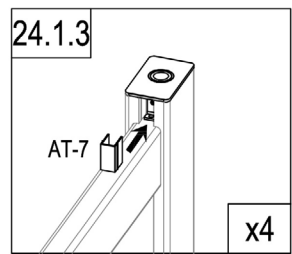
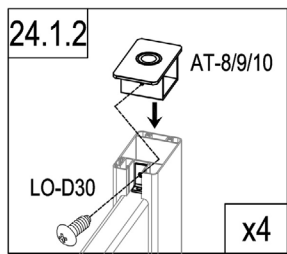
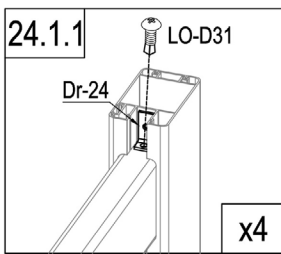
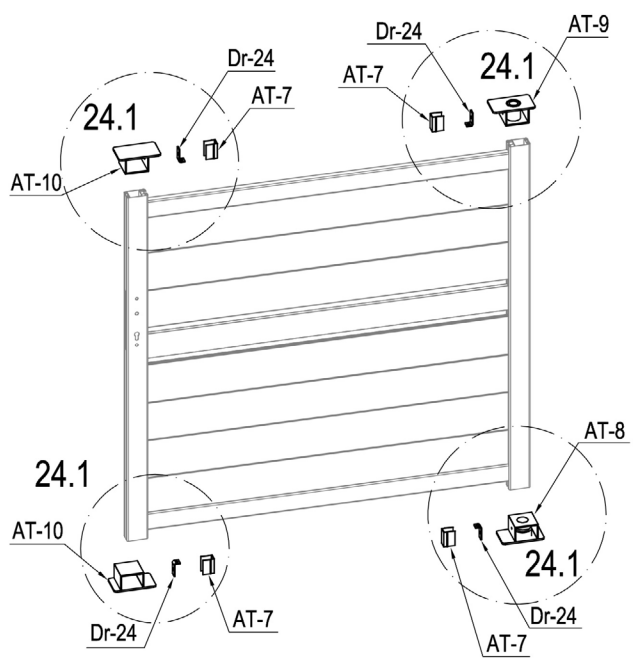

| | | |
|--|-------|---|
| | AT-8 | 1 |
| | AT-9 | 1 |
| | AT-10 | 2 |
| | Dr-24 | 4 |

| | | |
|--|--------|---|
| | AT-7 | 4 |
| | LO-D30 | 4 |
| | LO-D31 | 4 |

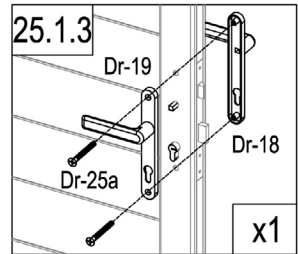
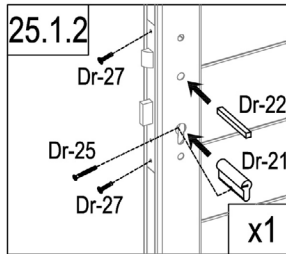
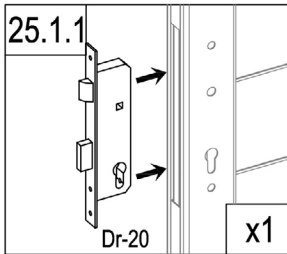
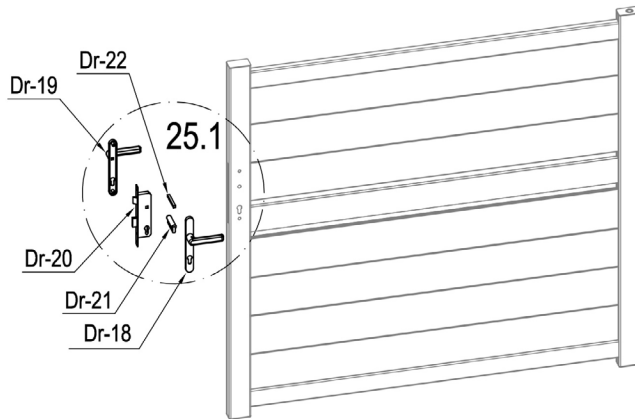

| | | |
|--|-------|---|
| | Dr-20 | 1 |
| | Dr-21 | 1 |
| | Dr-22 | 1 |
| | Dr-25 | 1 |

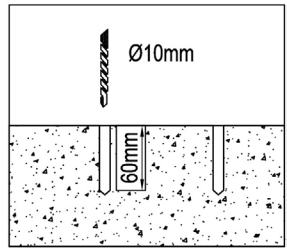
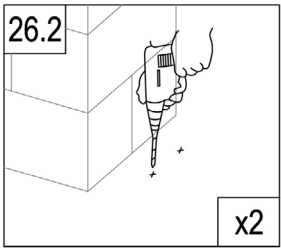
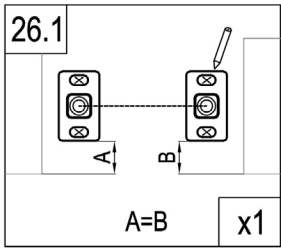
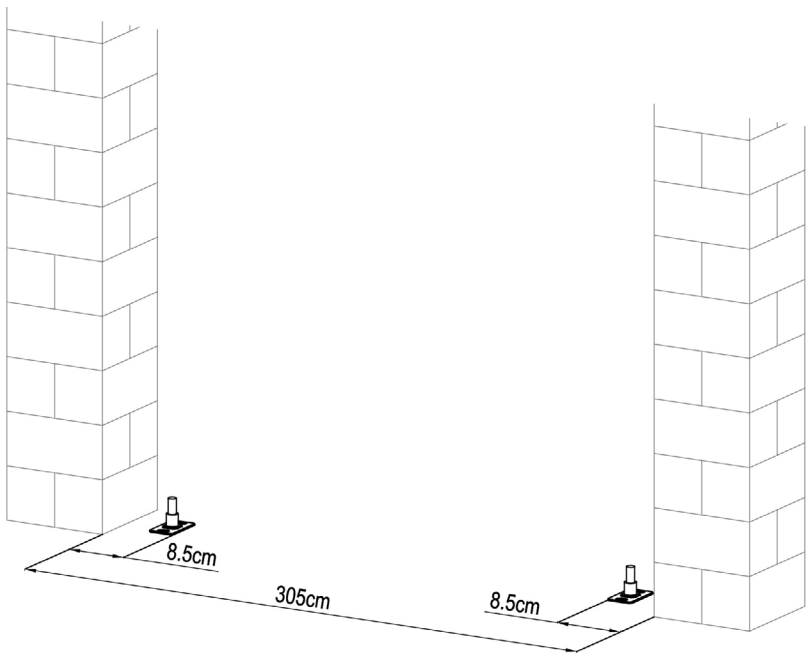

| | | |
|--|--------|---|
| | Dr-18 | 1 |
| | Dr-19 | 1 |
| | Dr-25a | 2 |
| | Dr-27 | 2 |

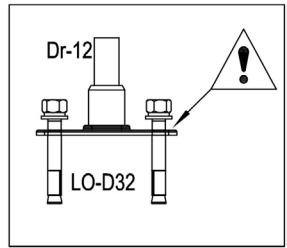
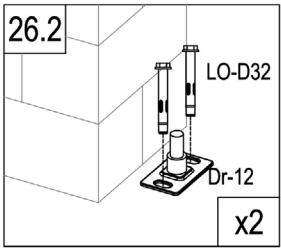

| | | |
|--|--------|---|
| | Dr-12 | 2 |
| | LO-D32 | 4 |

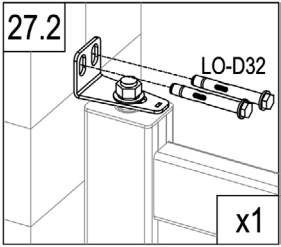
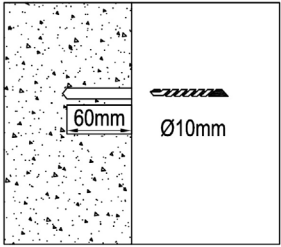
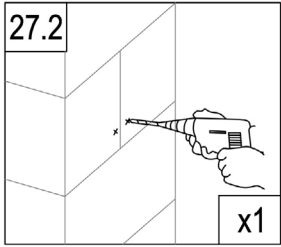
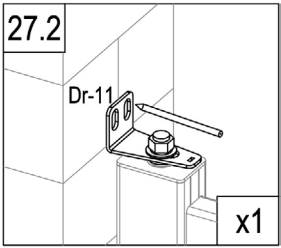
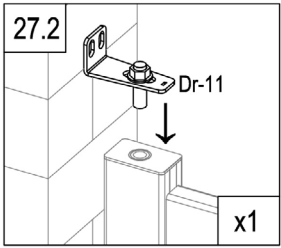
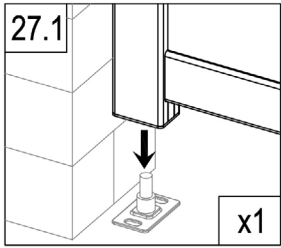
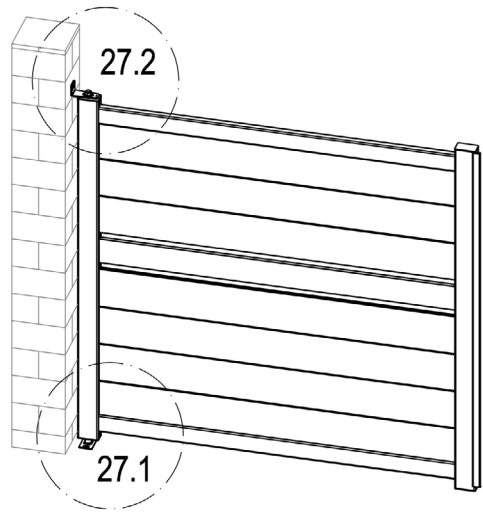





| | | |
|---|--------|---|
|  | Dr-11 | 1 |
|  | LO-D32 | 2 |

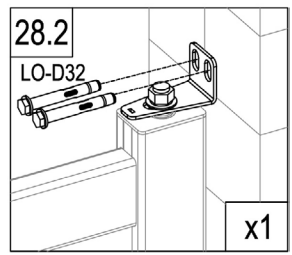
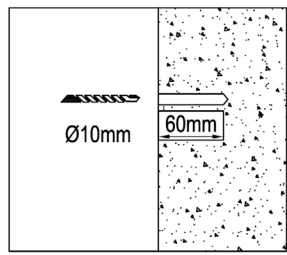
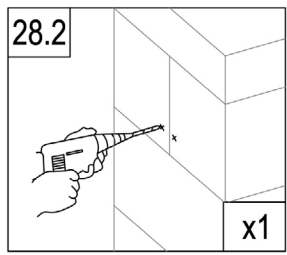
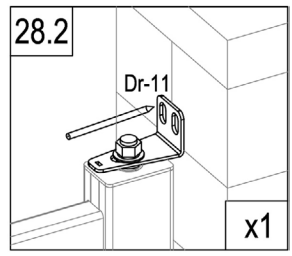
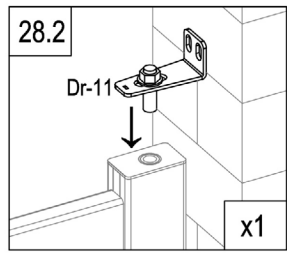
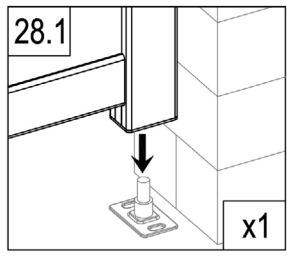
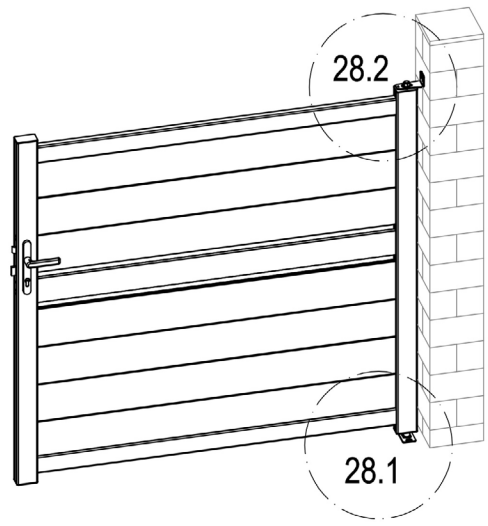

CASANOVO



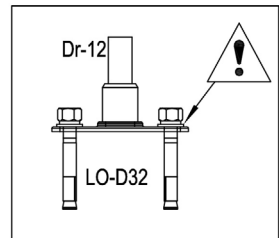
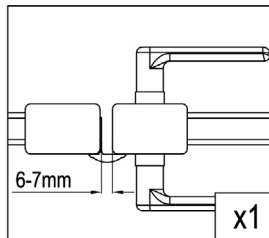
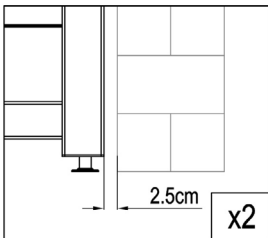
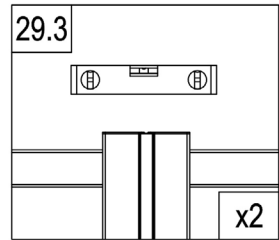
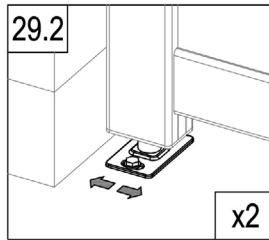
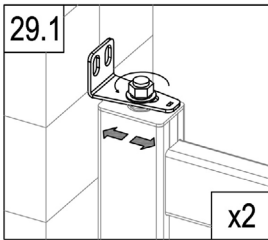
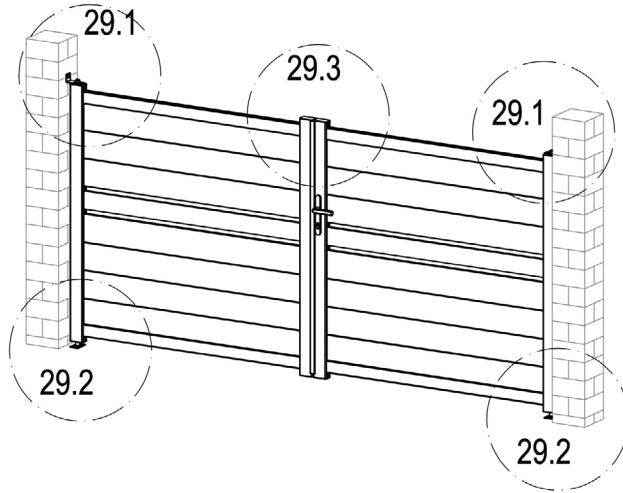

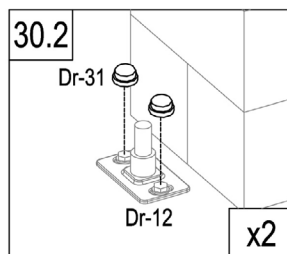
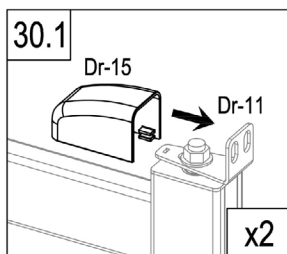
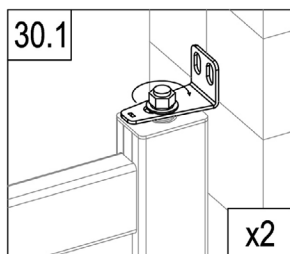
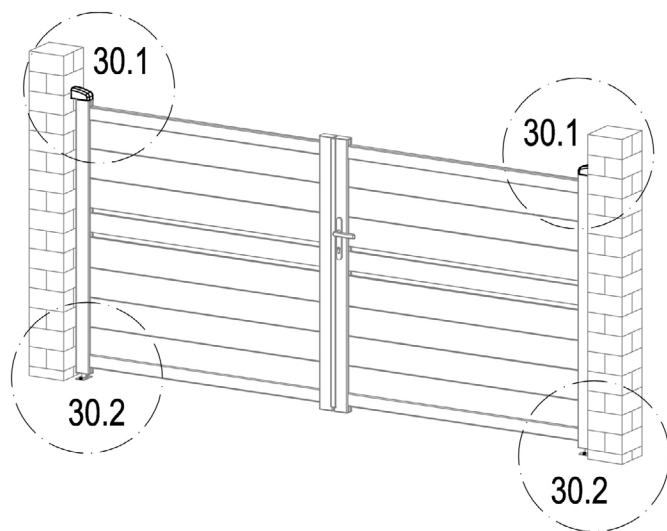

| | | |
|---|--------|---|
|  | Dr-11 | 1 |
|  | LO-D32 | 2 |



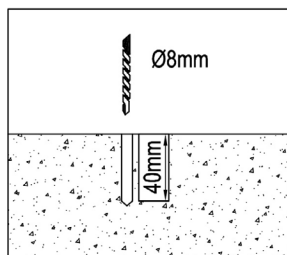
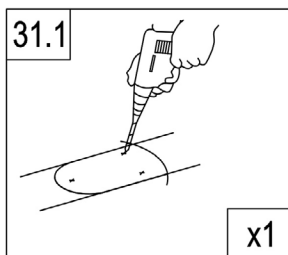
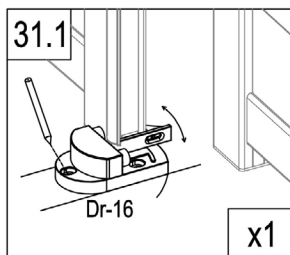
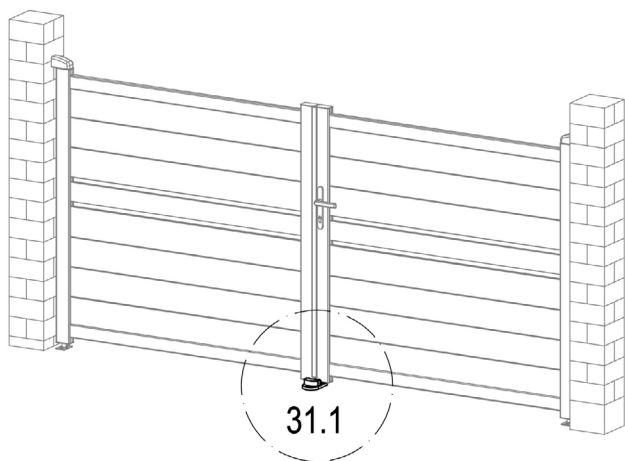



| | | |
|---|-------|---|
|  | Dr-15 | 2 |
|  | Dr-31 | 4 |

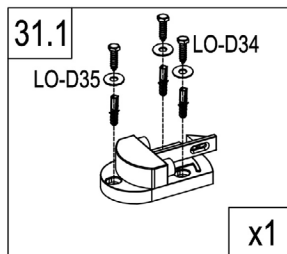

| | | |
|---|--------|---|
|  | Dr-16 | 1 |
|  | LO-D34 | 3 |
|  | LO-D35 | 3 |

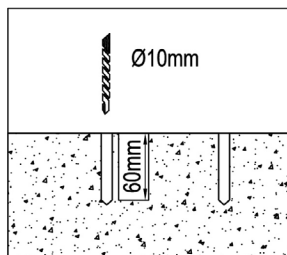
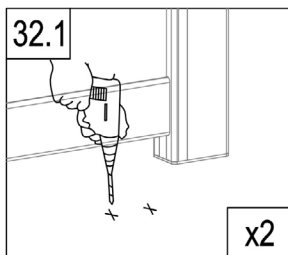
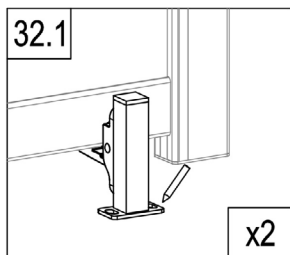
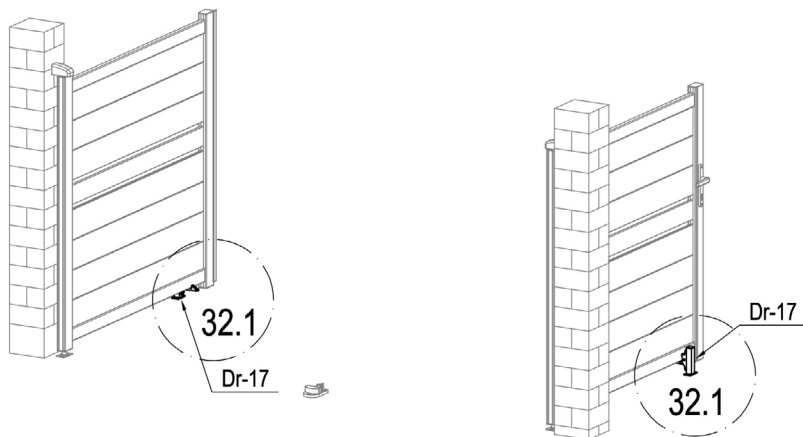



| | | |
|---|--------|---|
|  | LO-D32 | 4 |
|  | Dr-17 | 2 |

