

CASANOVO

CARPATIA 350B140

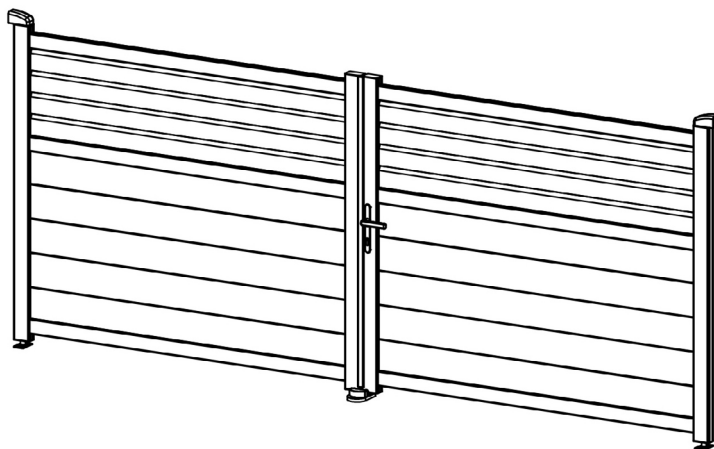

COM-001067 [x1]

COM-001068 [x1]





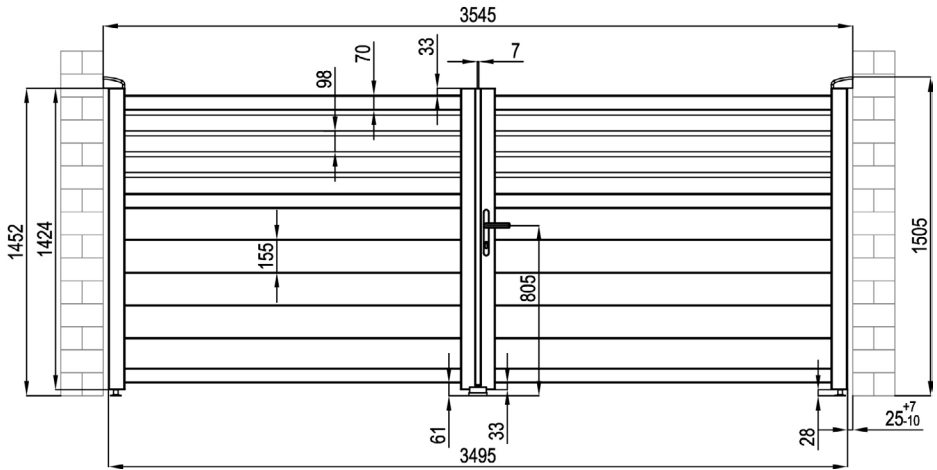

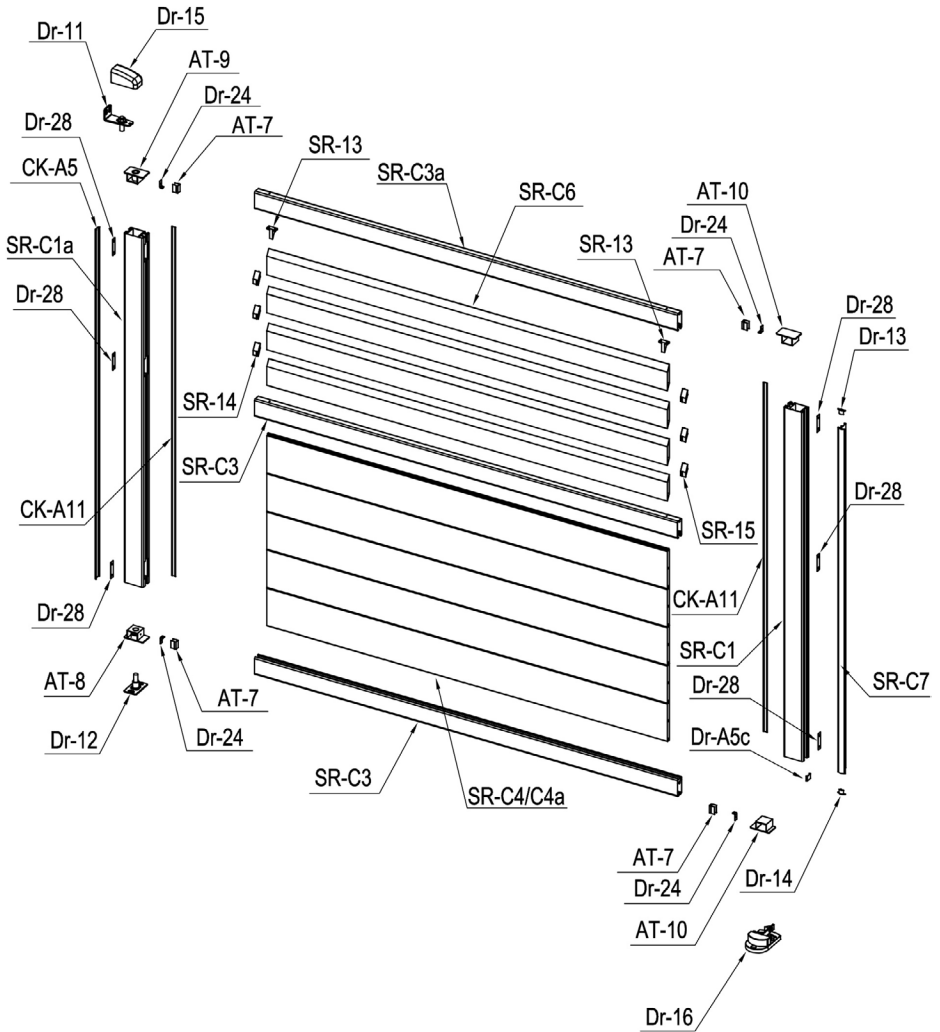

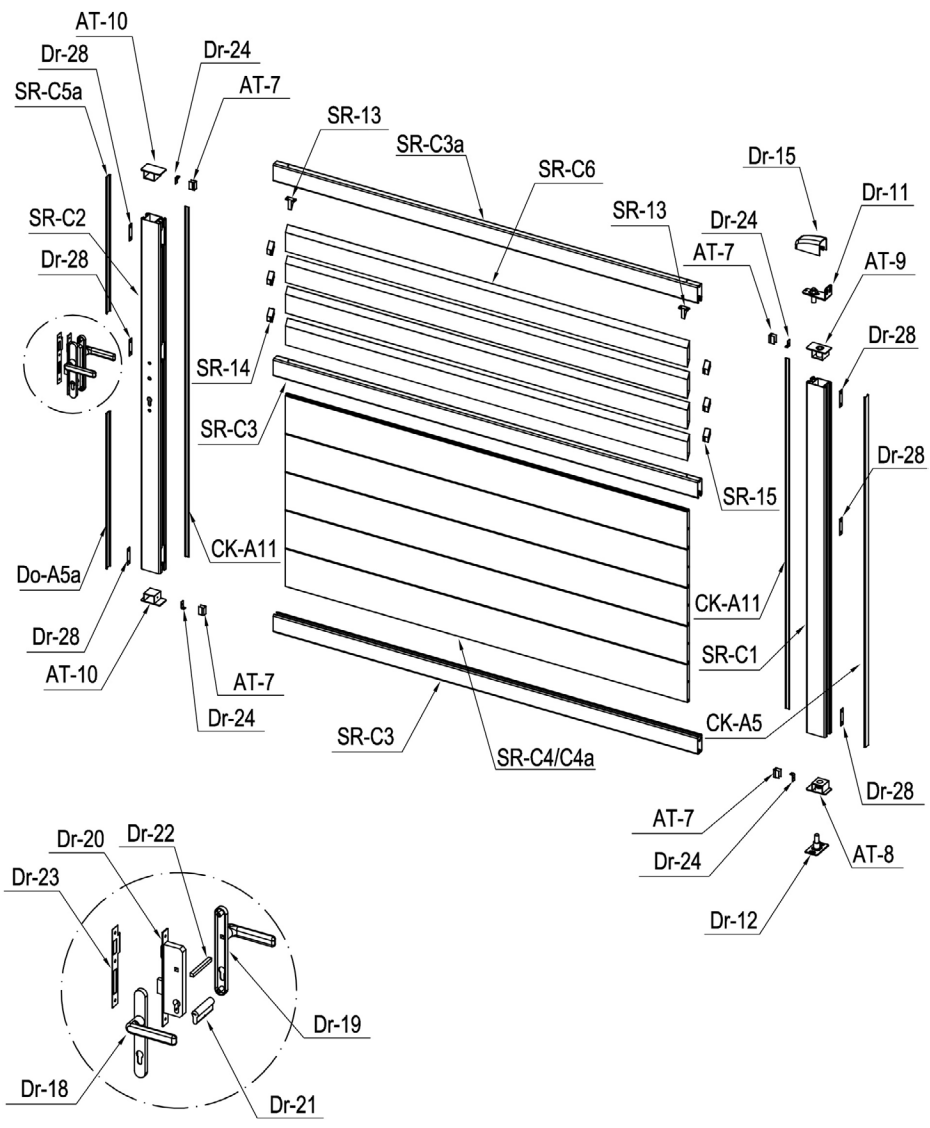



































INSTRUCTION MANUAL / NOTICE DE MONTAGE / MONTAGEANLEITUNG / MANUAL DE MONTAJE / MANUAL DE MONTAGEM / MANUALE DI MONTAGGIO /
MONTAGEHANDLEIDING / INSTRUKCJA MONTAŻU / KÄYTTÖOHJEET / BRUGSANVISNING / BRUGSANVISNING / INSTRUCIUNI DE ASAMBLARE /
NAVODILA ZA SESTAVLJANJE / NÁVOD NA MONTÁŽ / ÖSSZESZERELÉSI ÚTMUTATÓ / NÁVOD K MONTÁŽI / UPUTE ZA INSTALACIJU /
ΟΔΗΓΙΕΣ ΣΥΝΑΡΜΟΛΟΓΗΣΗΣ / SURINKIMO INSTRUKCIJOS / MONTĀŽAS INSTRUKCIJAS







CASANOVO

IMAGE	NO.	L.(mm)	QTY	IMAGE	NO.	L.(mm)	QTY
	SR-C1	1418	2		SR-15		6
	SR-C1a	1418	1		Dr-15		2
	SR-C2	1418	1		Dr-16		1
	SR-C3	1721	4		Dr-17		2
	SR-C3a	1721	2		Dr-31		4
	SR-C4	1630	8		Dr-18		1
	SR-C4a (+SR-C15)	1630	2		Dr-19		1
	SR-C6	1630	8		Dr-20		1
	CK-A5	1418	2		Dr-21		1
	SR-C5a	555.5	1		Dr-22		1
	Do-A5a	622	1		Dr-23		1
	Dr-A5c	19.5	1		Dr-25		1
	CK-A11	1418	4		Dr-25a		2
	AT-7	29.5	8		Dr-26		3
	SR-C7	1398	1		Dr-27		2
	AT-8		2		Dr-24		8
	AT-9		2		Dr-28		12
	AT-10		4		SR-S30	ST4x10	8
	Dr-11		2		SR-S31	ST4.2x13	16
	Dr-12		2		SR-S32	M8x60	12
	Dr-13		1		SR-S33	ST5.5x38	24
	Dr-14		1		SR-S34	ST6x40	3
	SR-13		4		SR-S35	Ø6	3
	SR-14		6		SR-S36	ST4.8x38	56

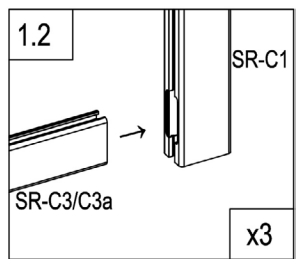
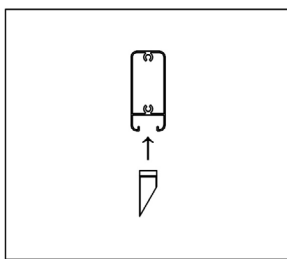
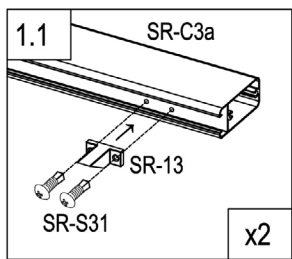
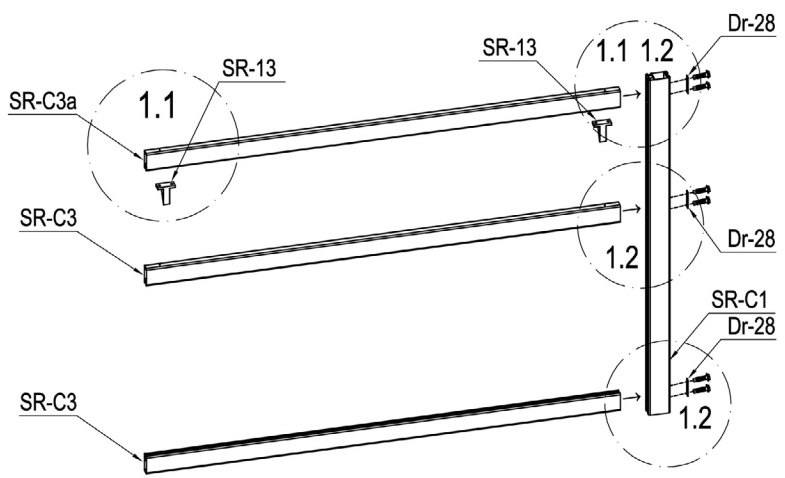

	SR-C1	1
	SR-C3	2
	SR-C3a	1
	SR-13	2

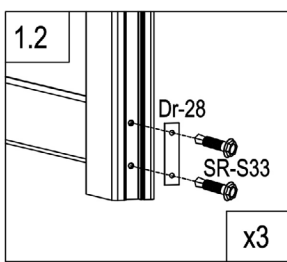

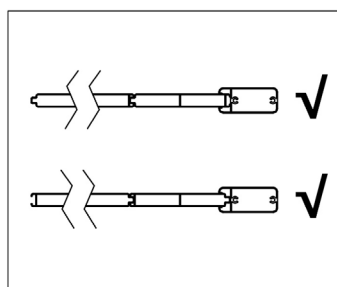
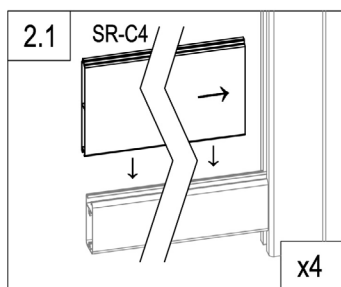
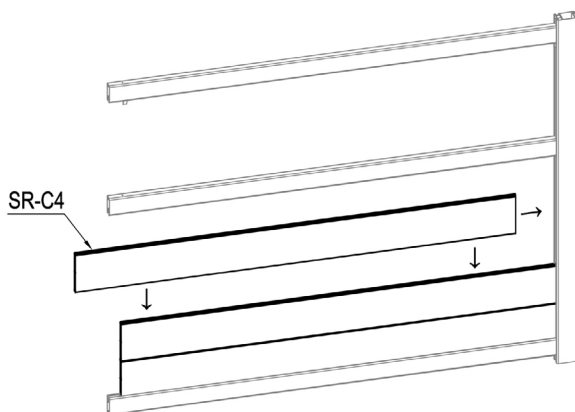

	Dr-28	3
	SR-S31	4
	SR-S33	6



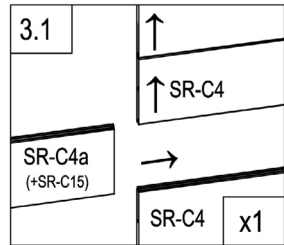
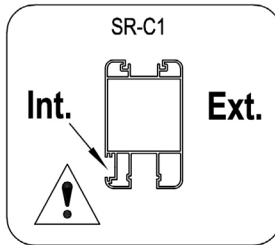
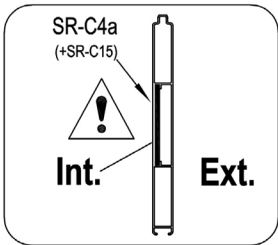
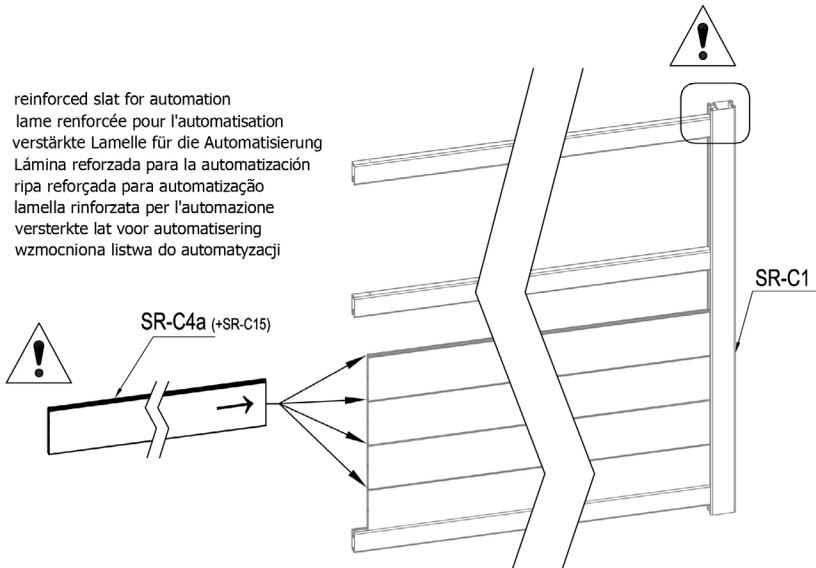

	SR-C4	4
---	-------	---

- EN: reinforced slat for automation
- FR: lame renforcée pour l'automatisation
- DE: verstärkte Lamelle für die Automatisierung
- ES: Lámina reforzada para la automatización
- PT: ripa reforçada para automatização
- IT: lamella rinforzata per l'automazione
- NL: versterkte lat voor automatisering
- PL: wzmocniona listwa do automatyzacji



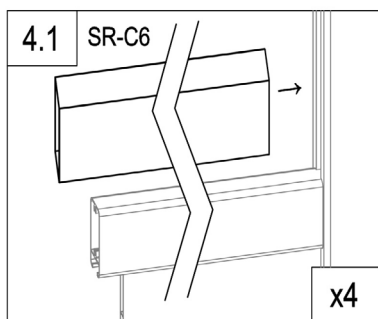
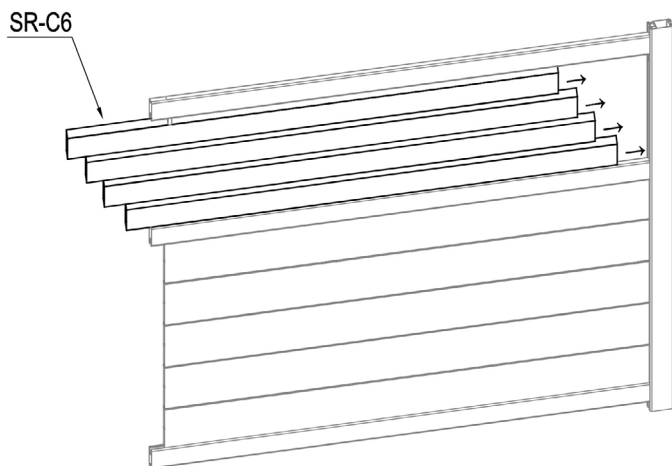

	SR-C4a (+SR-C15)	1
---	------------------	---



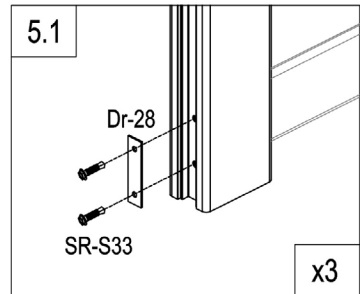
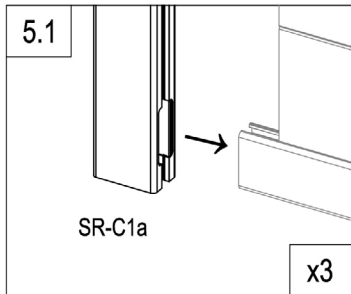
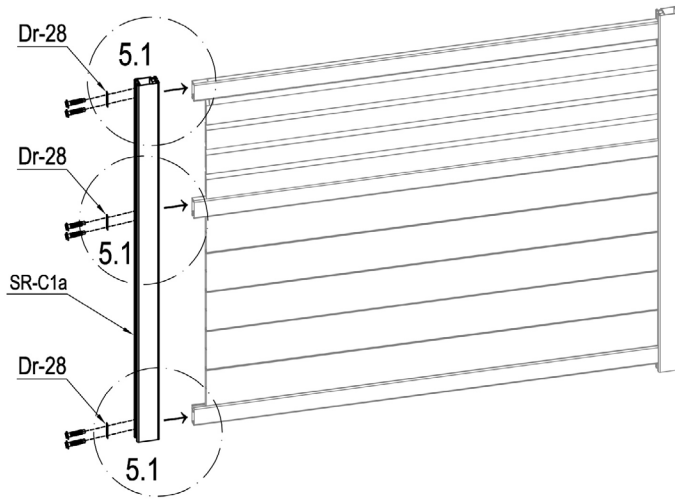

	SR-C6	4
---	-------	---

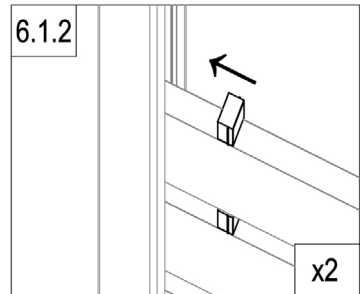
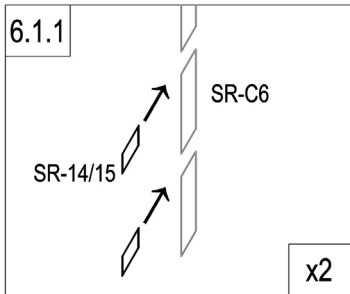
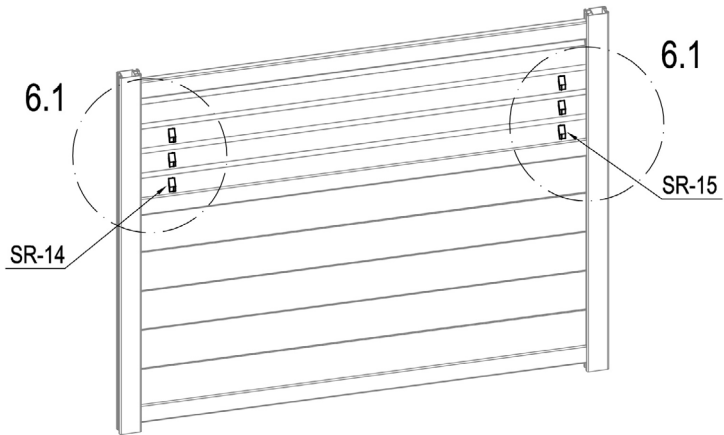

	SR-C1a	1
	Dr-28	3
	SR-S33	6



	SR-14	3
	SR-15	3

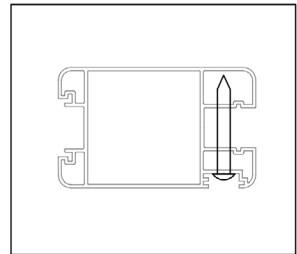
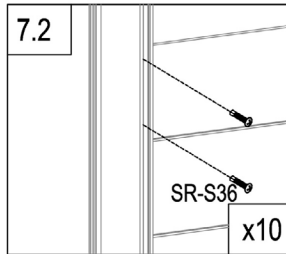
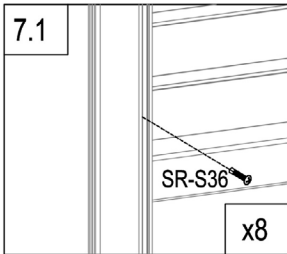
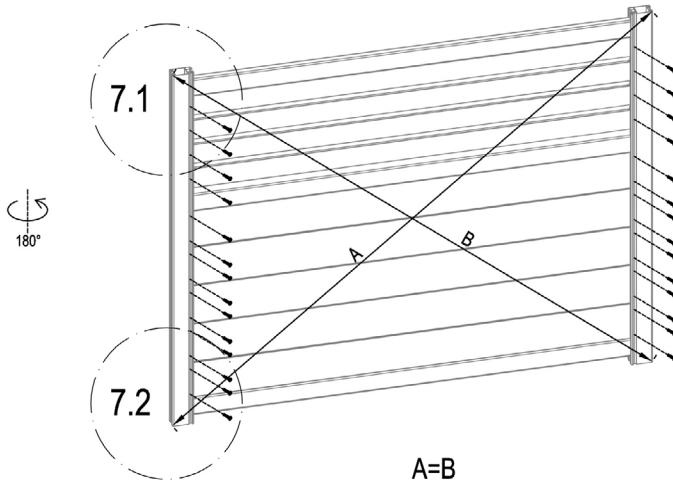

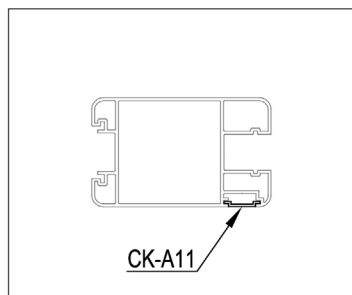
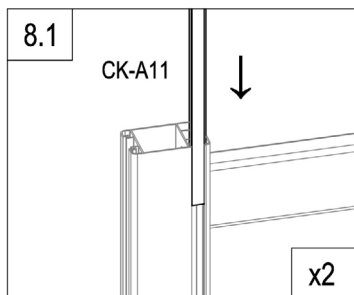
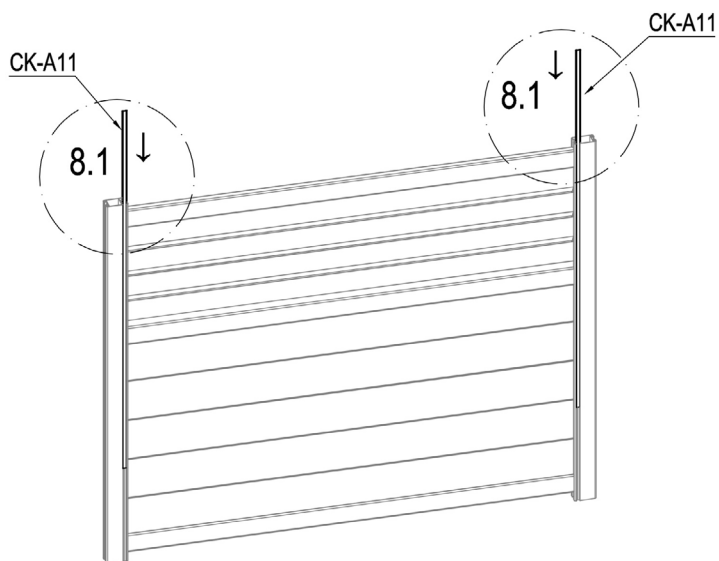

	SR-S36	28
---	--------	----

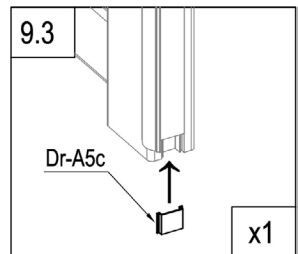
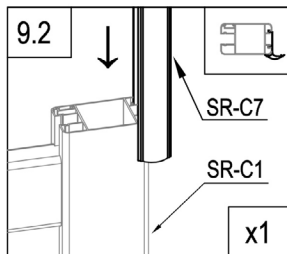
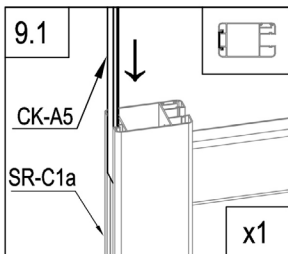
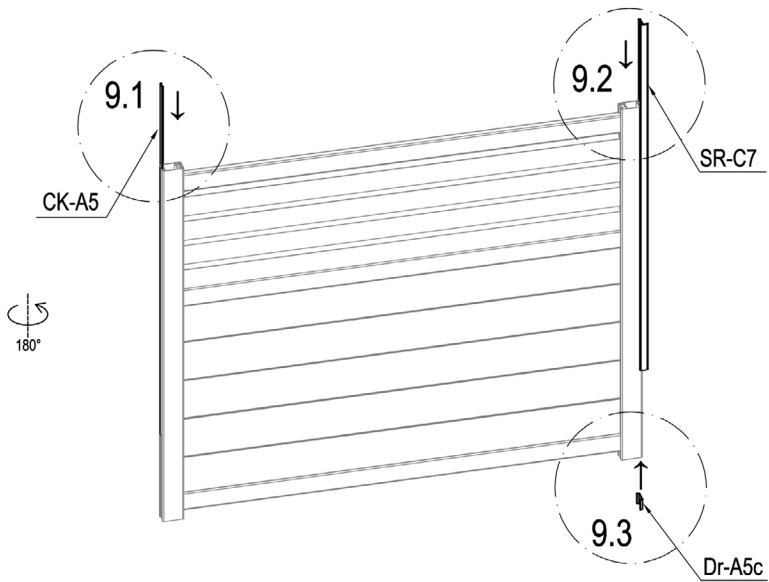

	CK-A11	2
---	--------	---



	CK-A5	1
	Dr-A5c	1
	SR-C7	1

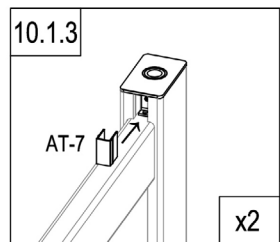
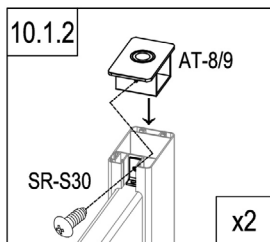
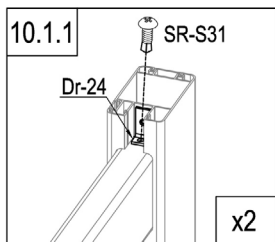
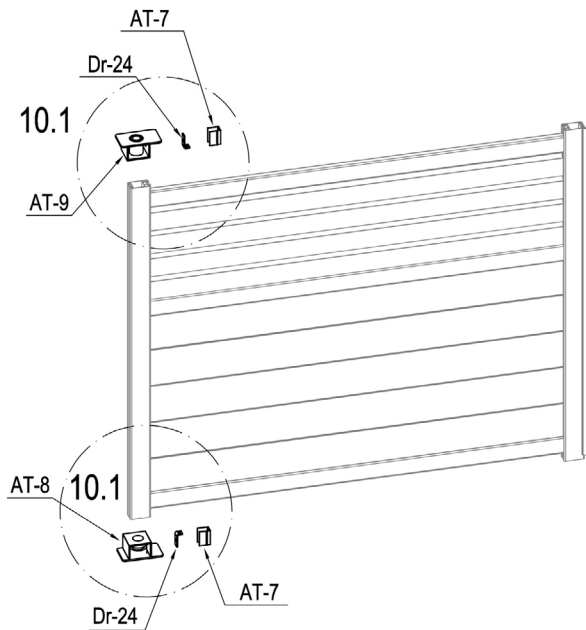

	AT-8	1
	AT-9	1
	Dr-24	2

	AT-7	2
	SR-S30	2
	SR-S31	2

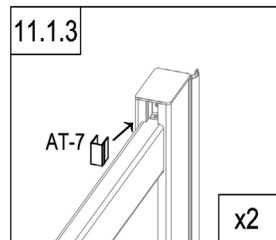
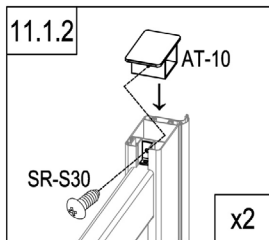
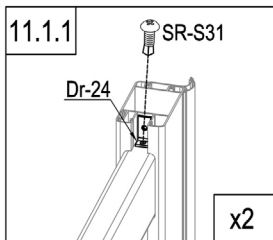
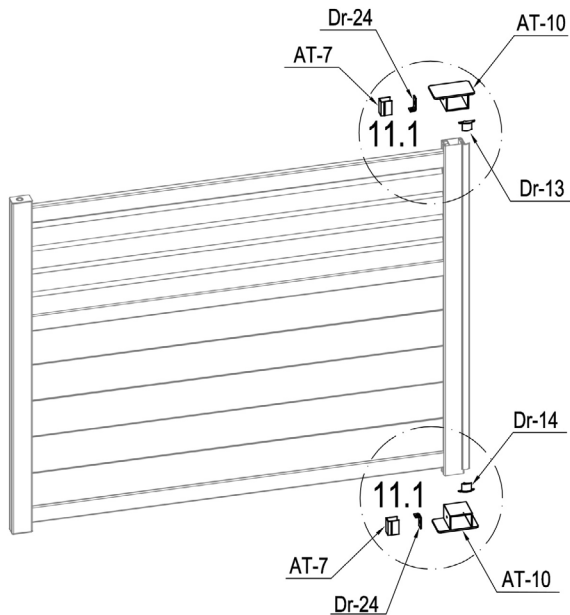

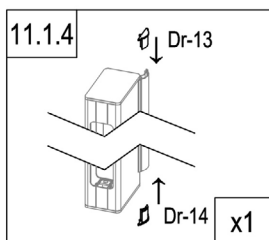

	AT-10	2
	Dr-24	2
	AT-7	2
	Dr-13	1

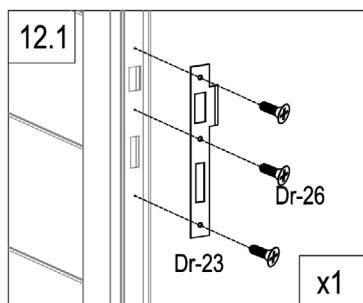
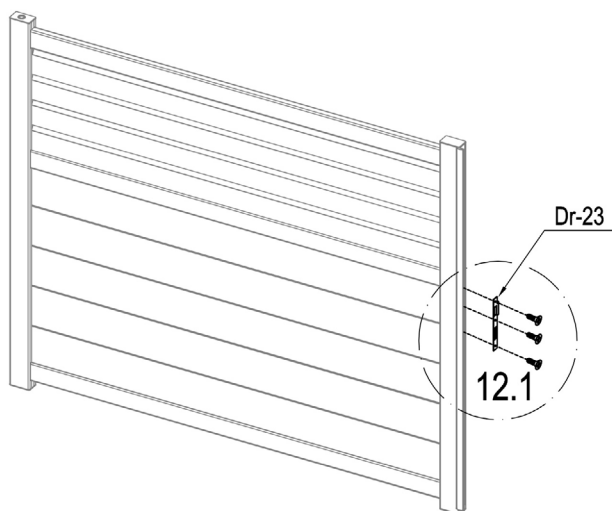

	Dr-14	1
	SR-S30	2
	SR-S31	2



	Dr-23	1
	Dr-26	3

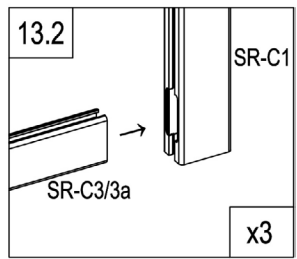
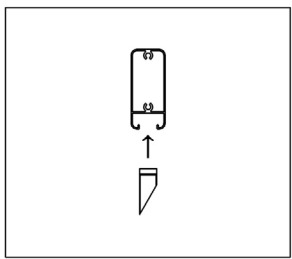
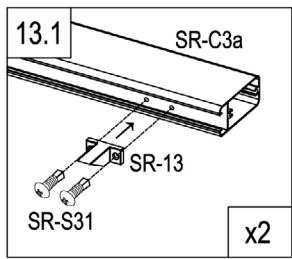
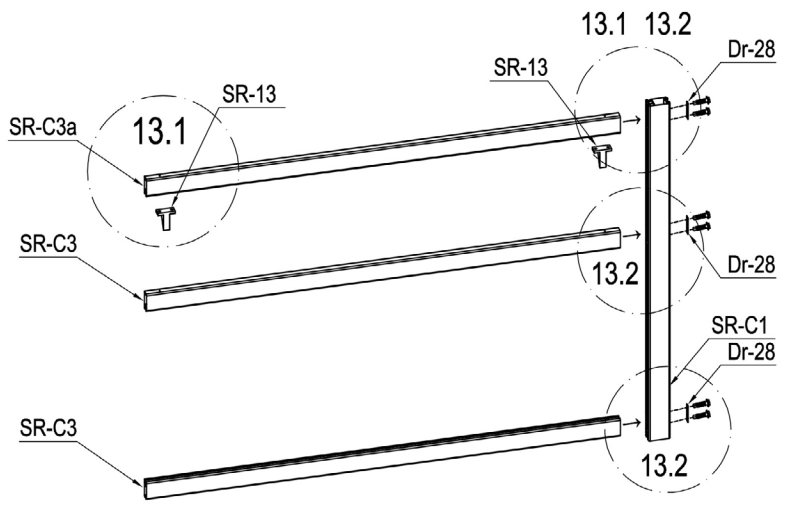

	SR-C1	1
	SR-C3	2
	SR-C3a	1
	SR-13	2

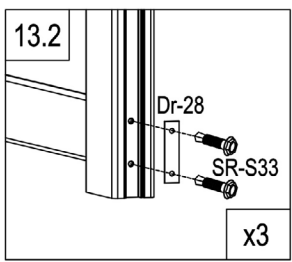

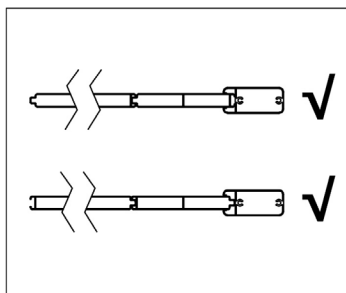
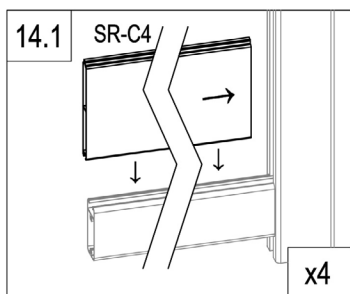
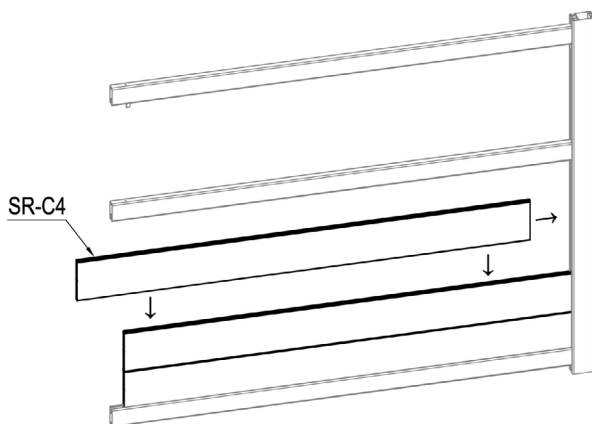

	Dr-28	3
	SR-S31	4
	SR-S33	6



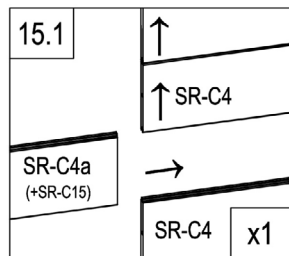
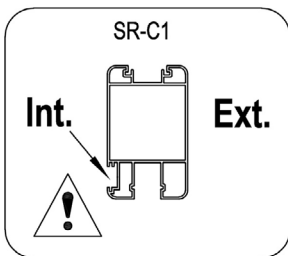
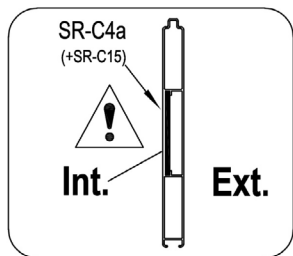
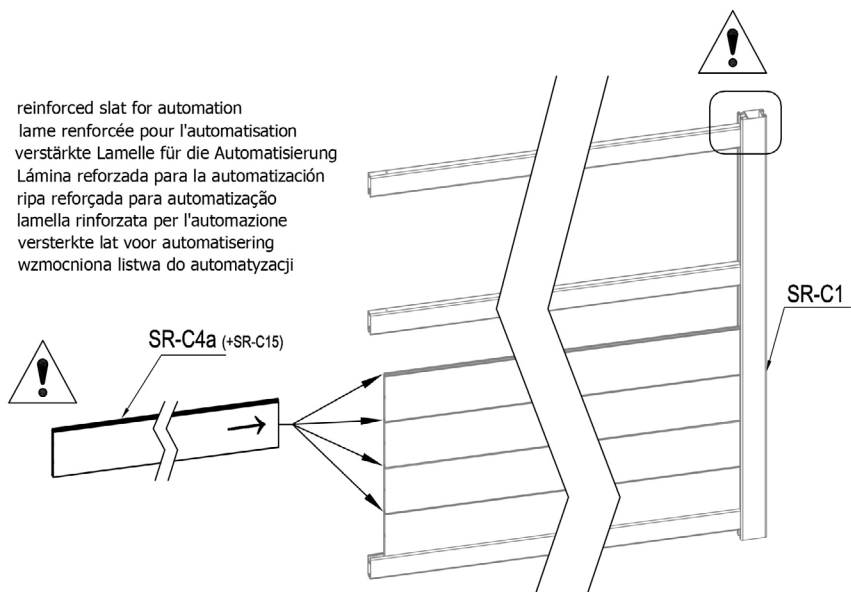

	SR-C4	4
---	-------	---

- EN: reinforced slat for automation
- FR: lame renforcée pour l'automatisation
- DE: verstärkte Lamelle für die Automatisierung
- ES: Lámina reforzada para la automatización
- PT: ripa reforçada para automatização
- IT: lamella rinforzata per l'automazione
- NL: versterkte lat voor automatisering
- PL: wzmocniona listwa do automatyzacji



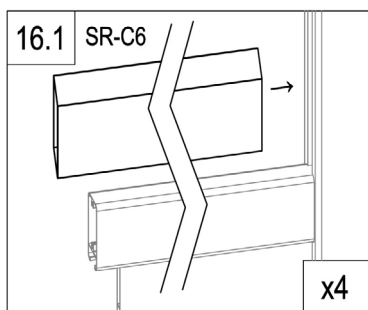
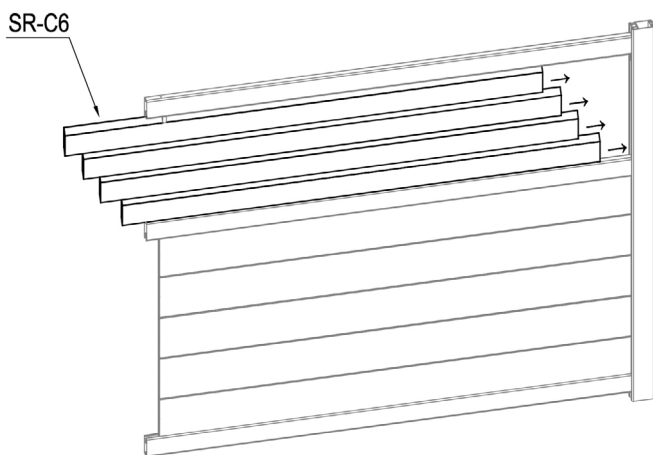

	SR-C4a (+SR-C15)	1
--	------------------	---



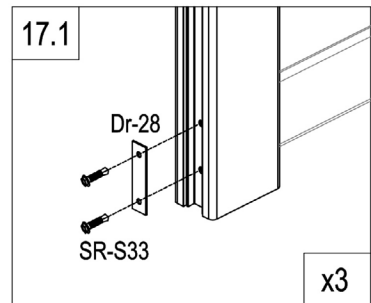
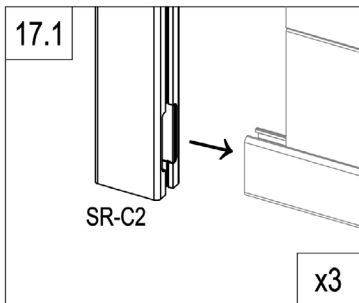
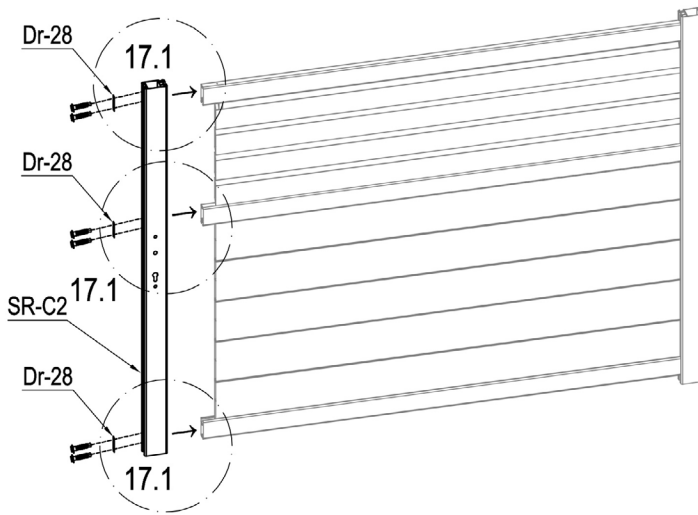

	SR-C6	4
---	-------	---

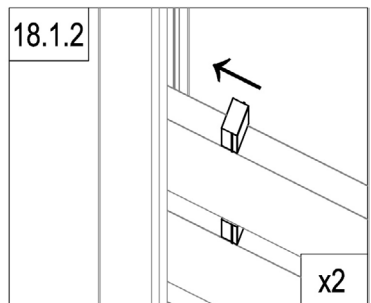
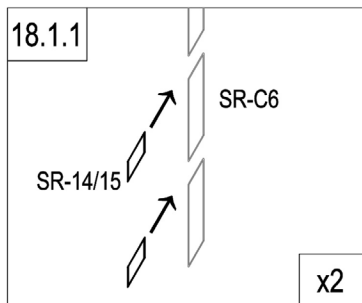
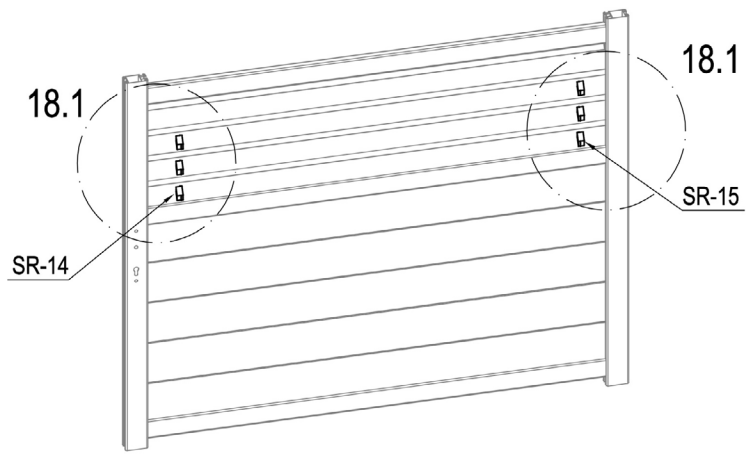

	SR-C2	1
	Dr-28	3
	SR-S33	6



	SR-14	3
	SR-15	3

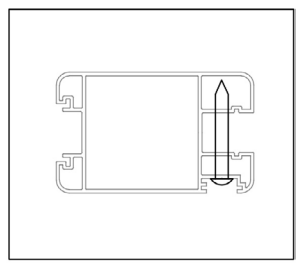
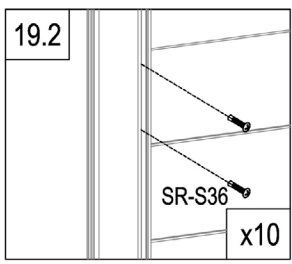
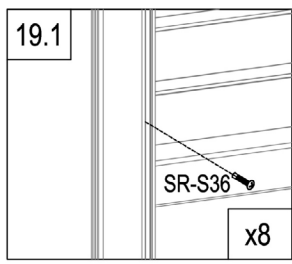
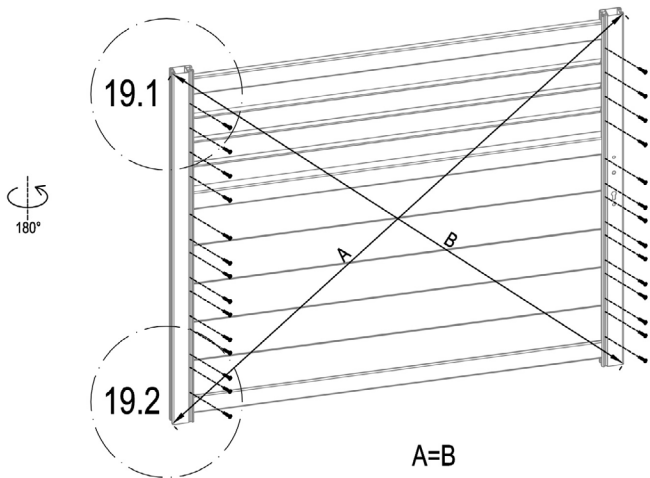

	SR-S36	28
---	--------	----

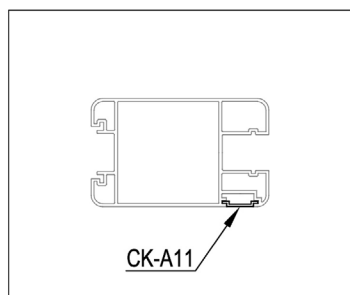
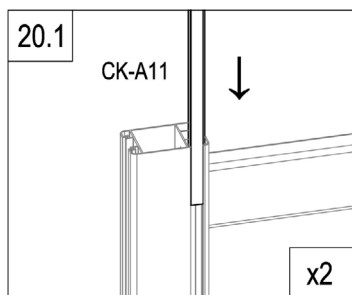
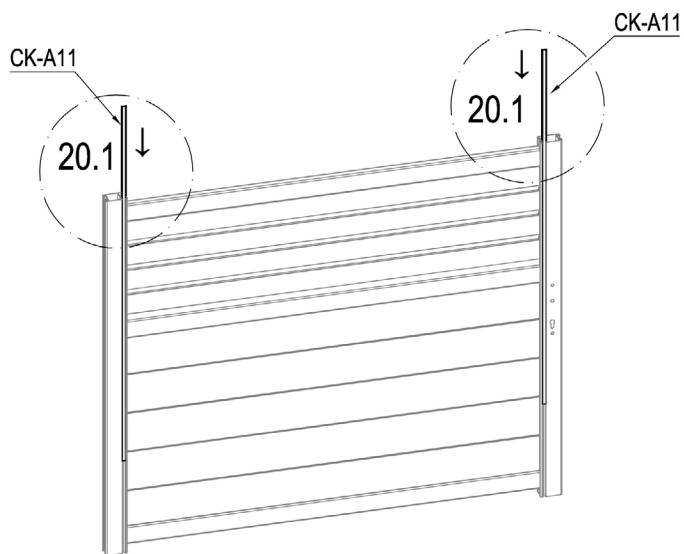

	CK-A11	2
---	--------	---

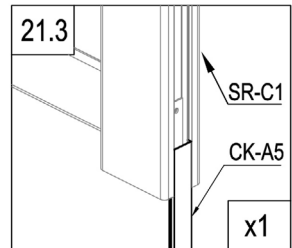
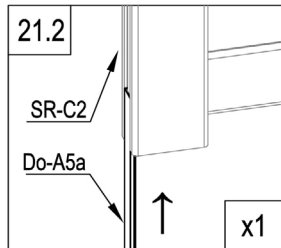
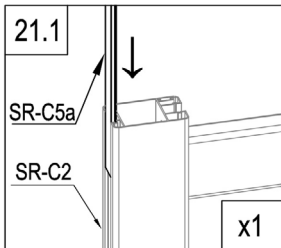
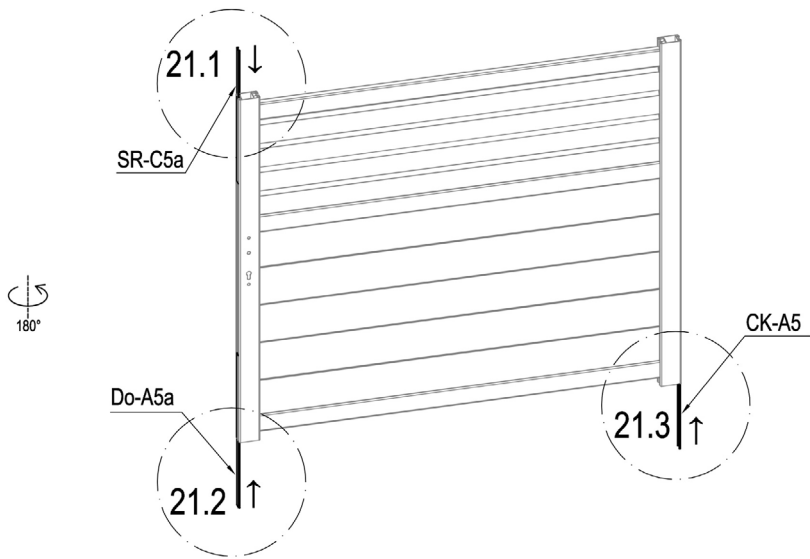

	CK-A5	1
	SR-C5a	1
	Do-A5a	1

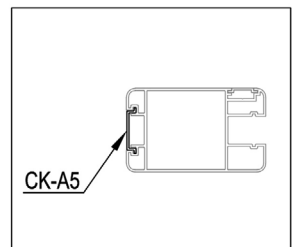

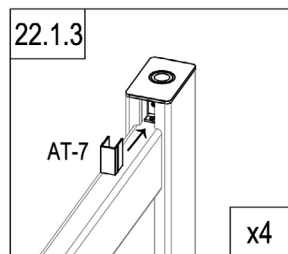
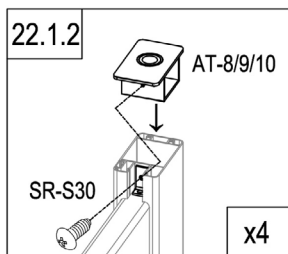
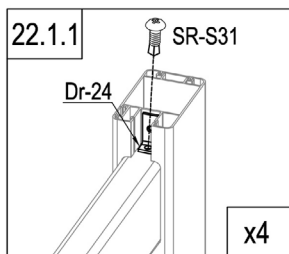
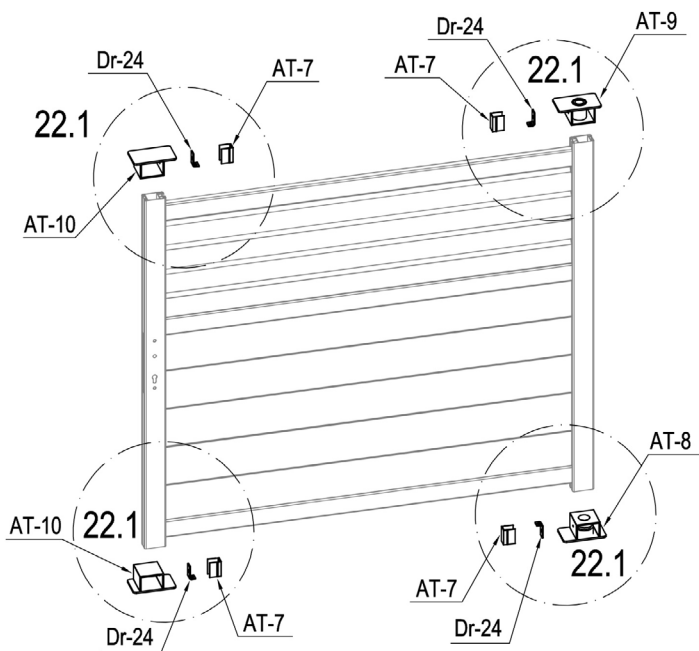

	AT-8	1
	AT-9	1
	AT-10	2
	Dr-24	4

	AT-7	4
	SR-S30	4
	SR-S31	4

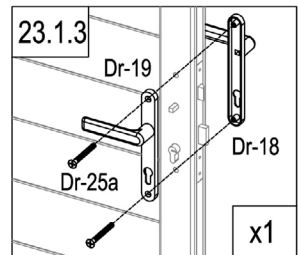
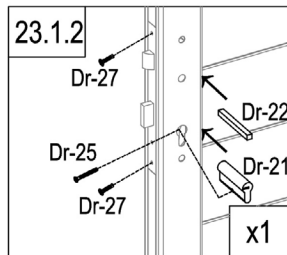
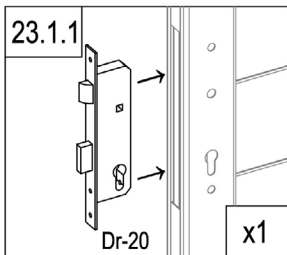
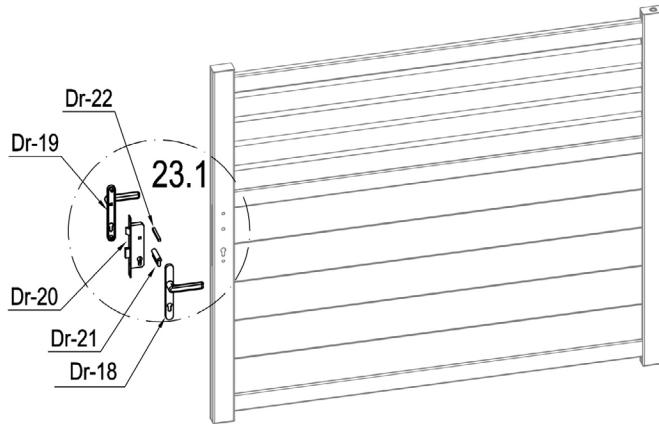

	Dr-20	1
	Dr-21	1
	Dr-22	1
	Dr-25	1

	Dr-18	1
	Dr-19	1
	Dr-25a	2
	Dr-27	2

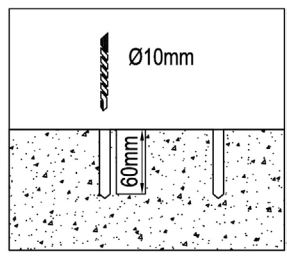
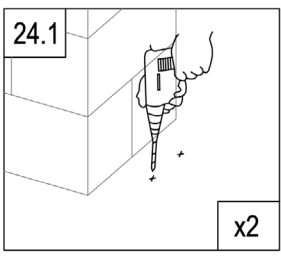
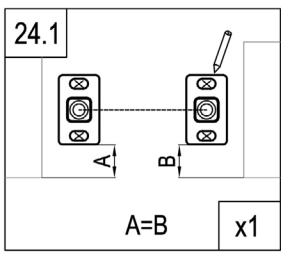
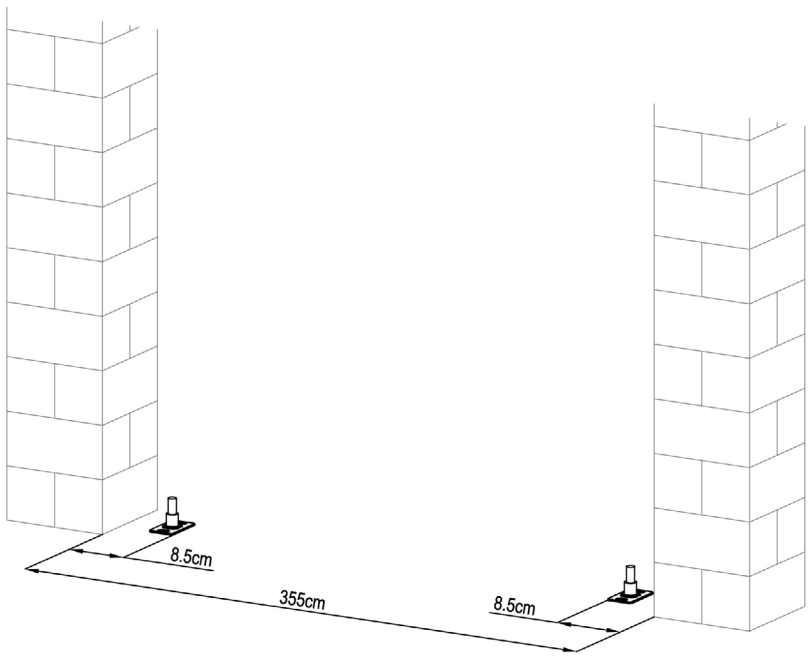

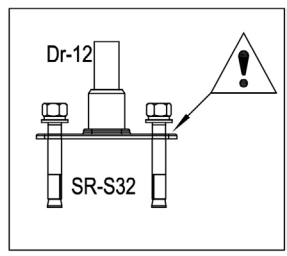
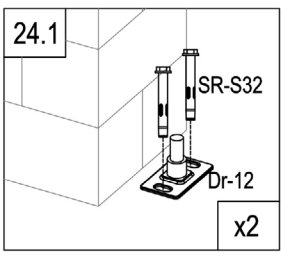

	Dr-12	2
	SR-S32	4



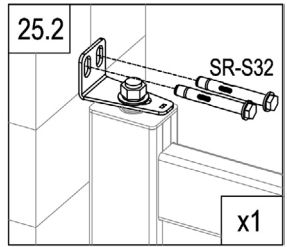
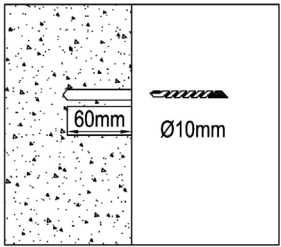
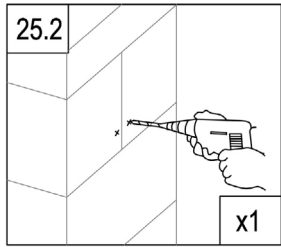
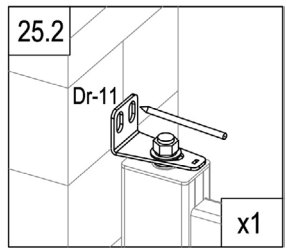
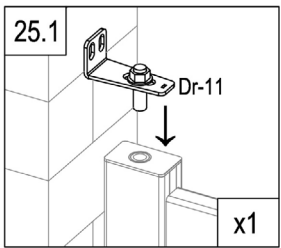
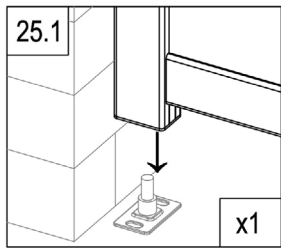
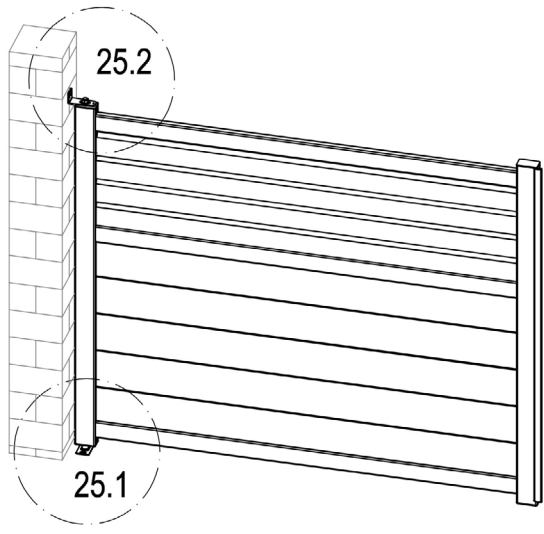

CASANOVO



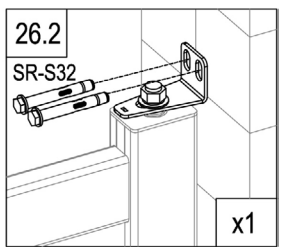
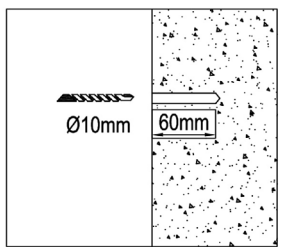
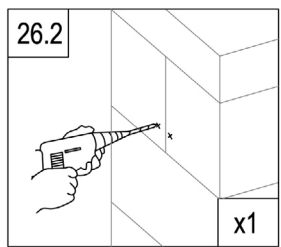
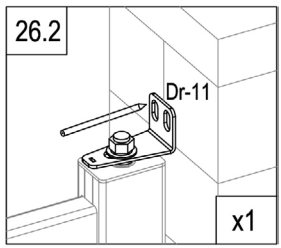
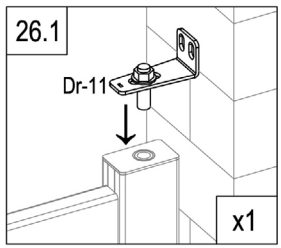
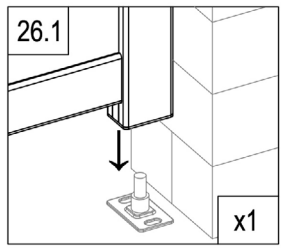
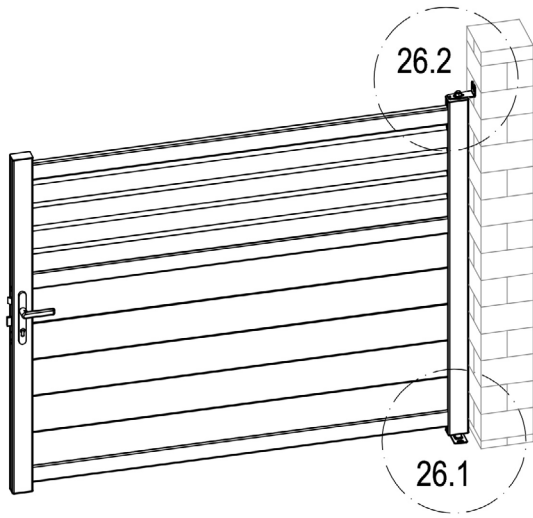

	Dr-11	1
	SR-S32	2



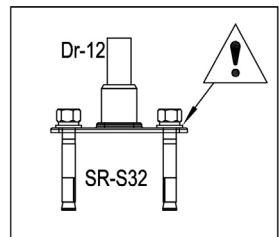
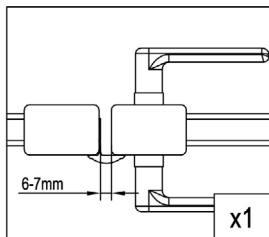
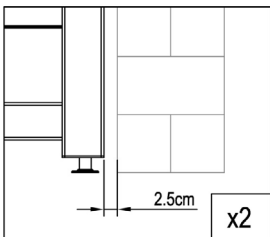
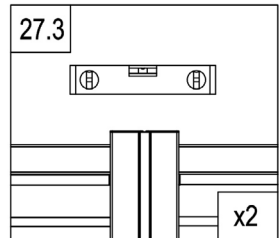
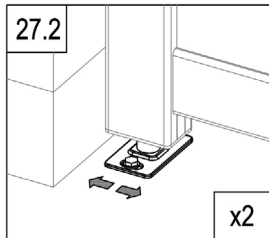
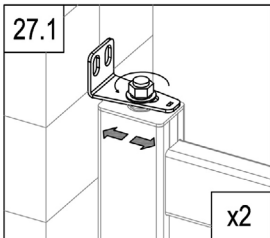
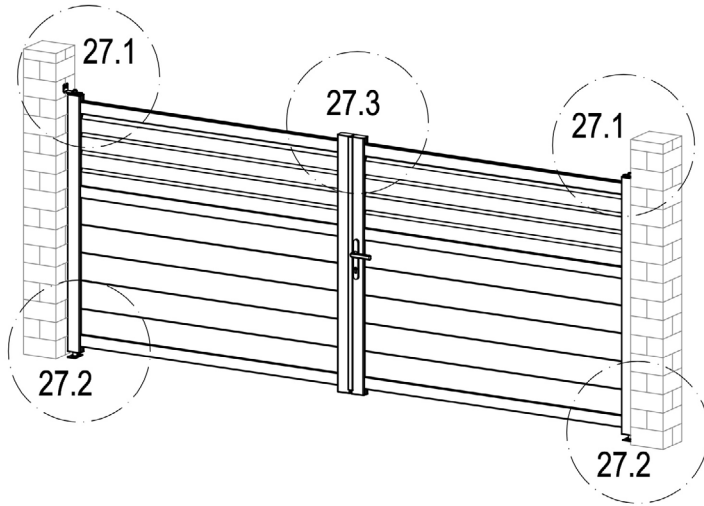

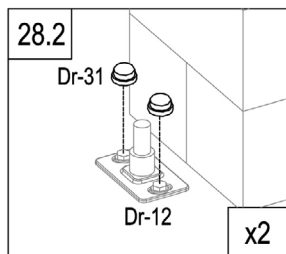
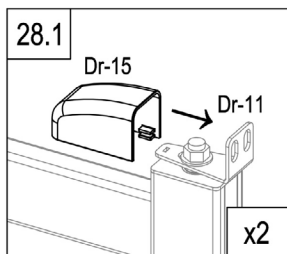
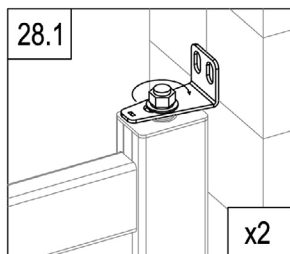
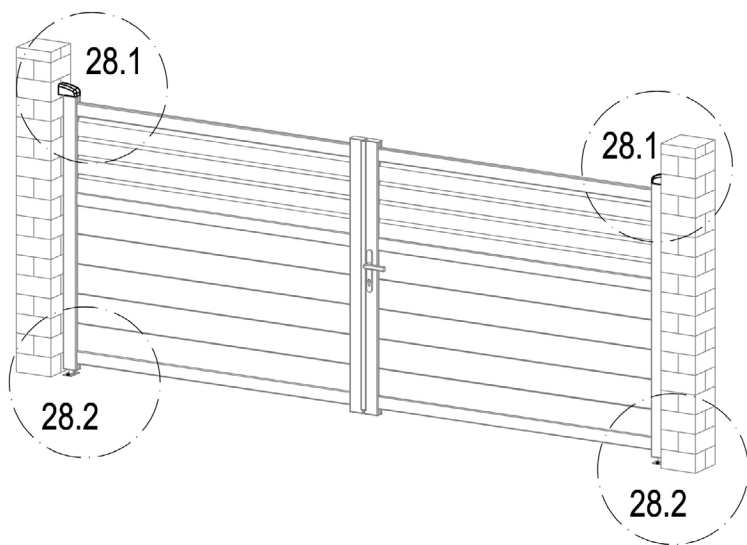

	Dr-11	1
	SR-S32	2



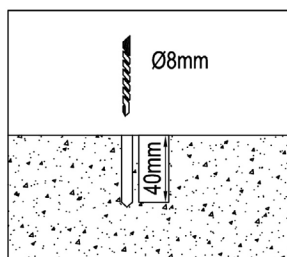
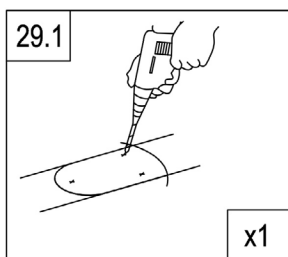
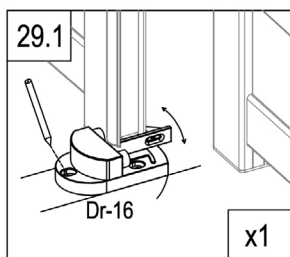
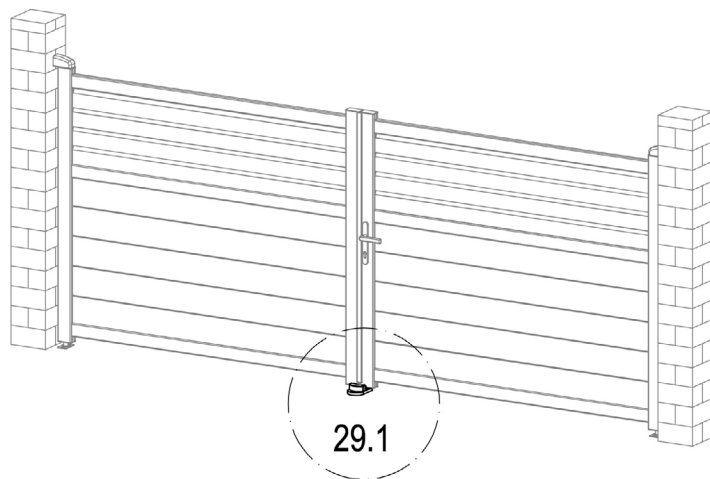

	Dr-15	2
	Dr-31	4



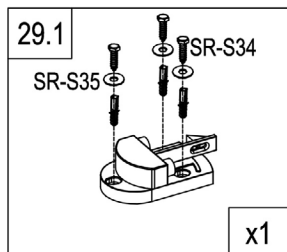

	Dr-16	1
	SR-S34	3
	SR-S35	3

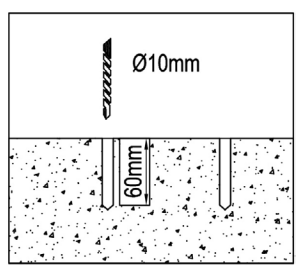
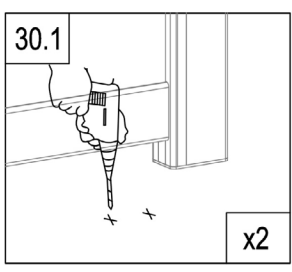
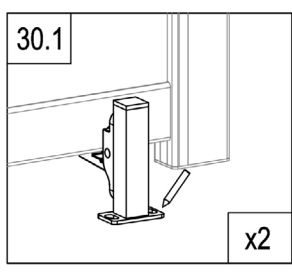
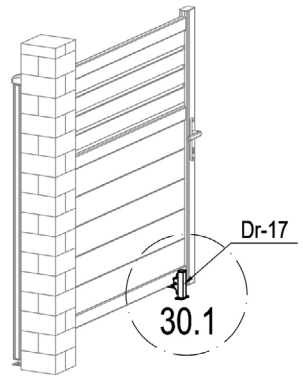
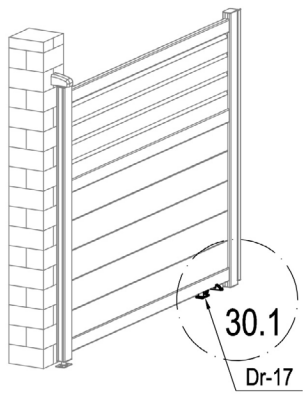

CASANOVO



	SR-S32	4
	Dr-17	2

