

CASANOVO

VOGEL 500C140

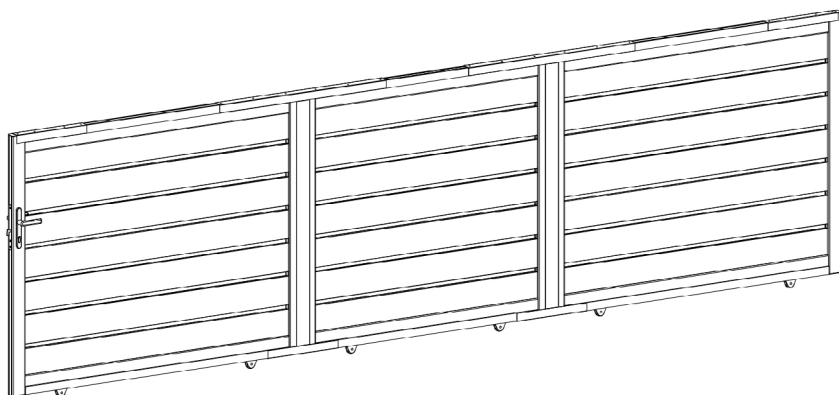

COM-000291 [x1]

COM-000293 [x1]

COM-000781 [x1]

COM-000292 [x1]

COM-000294 [x1]



INSTRUCTION MANUAL / NOTICE DE MONTAGE / MONTAGEANLEITUNG / MANUAL DE MONTAJE / MANUAL DE MONTAGEM / MANUALE DI MONTAGGIO /
MONTAGEHANDLEIDING / INSTRUKCJA MONTAŻU / KÄYTTÖOHJEET / BRUKSANVISNING / BRUGSANVISNING / INSTRUCȚIUNI DE ASAMBLARE /
NAVODILA ZA SESTAVLJANJE / NÁVOD NA MONTÁŽ / ÖSSZESZERELÉSI ÚTMUTATÓ / NÁVOD K MONTÁŽI / UPUTE ZA INSTALACIJU /
ΟΔΗΓΙΕΣ ΣΥΝΑΡΜΟΛΟΓΗΣΗΣ / SURINKIMO INSTRUKCIJOS / MONTĀŽAS INSTRUKCIJAS

Ext.

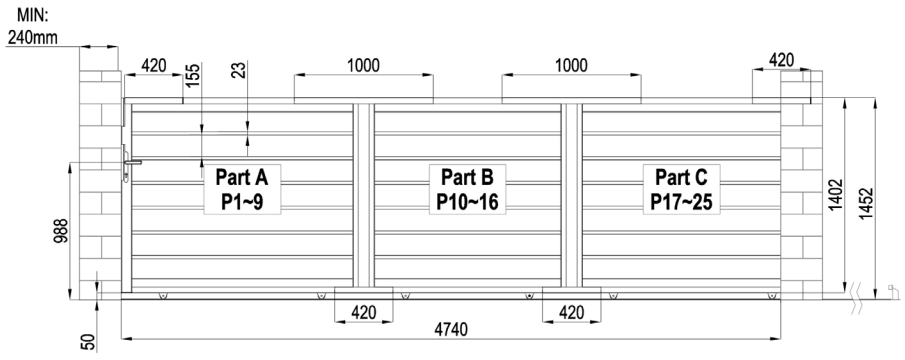

Int.

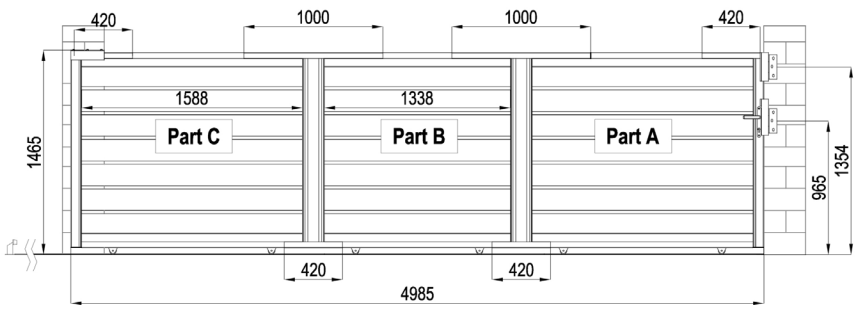

Part A.

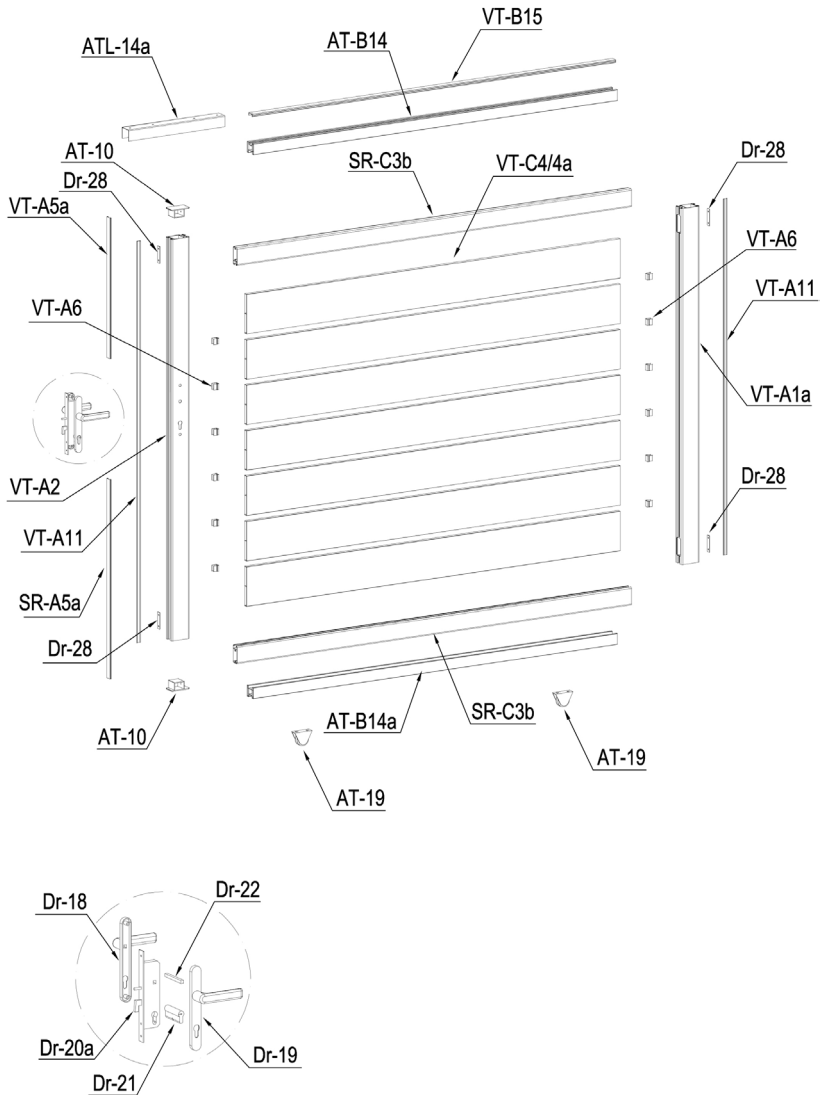

Part B.

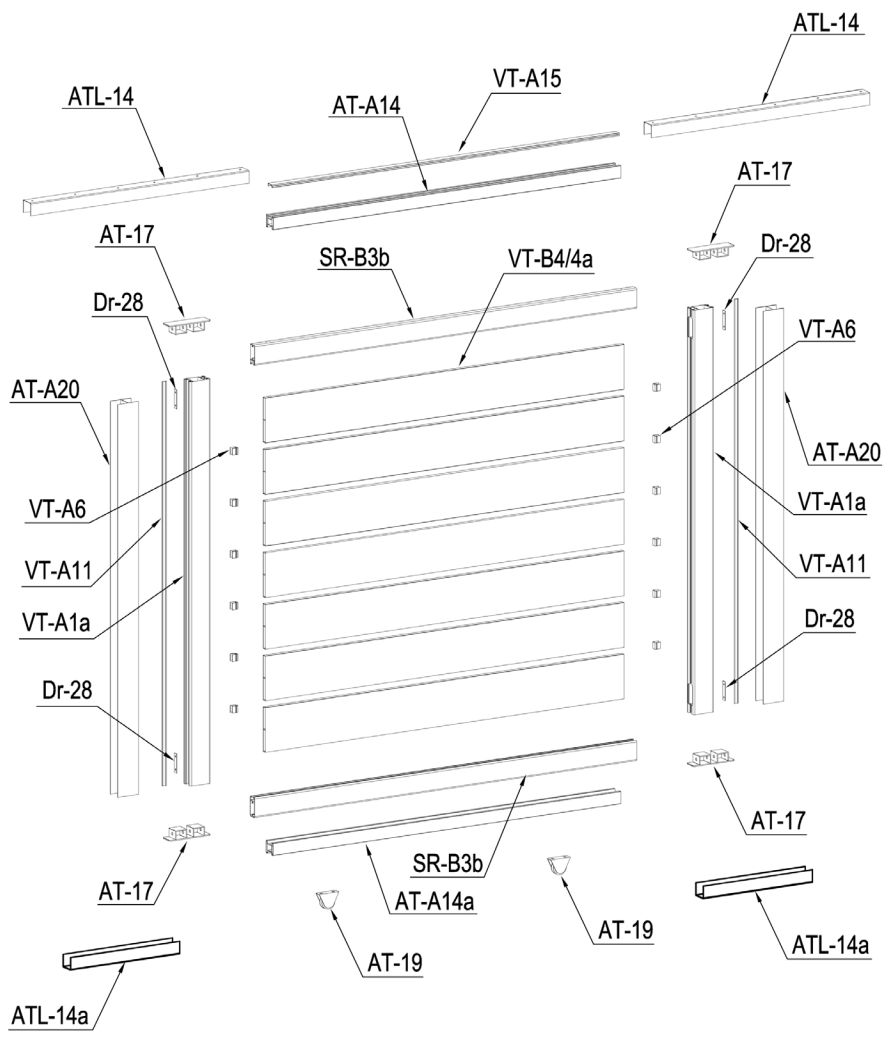



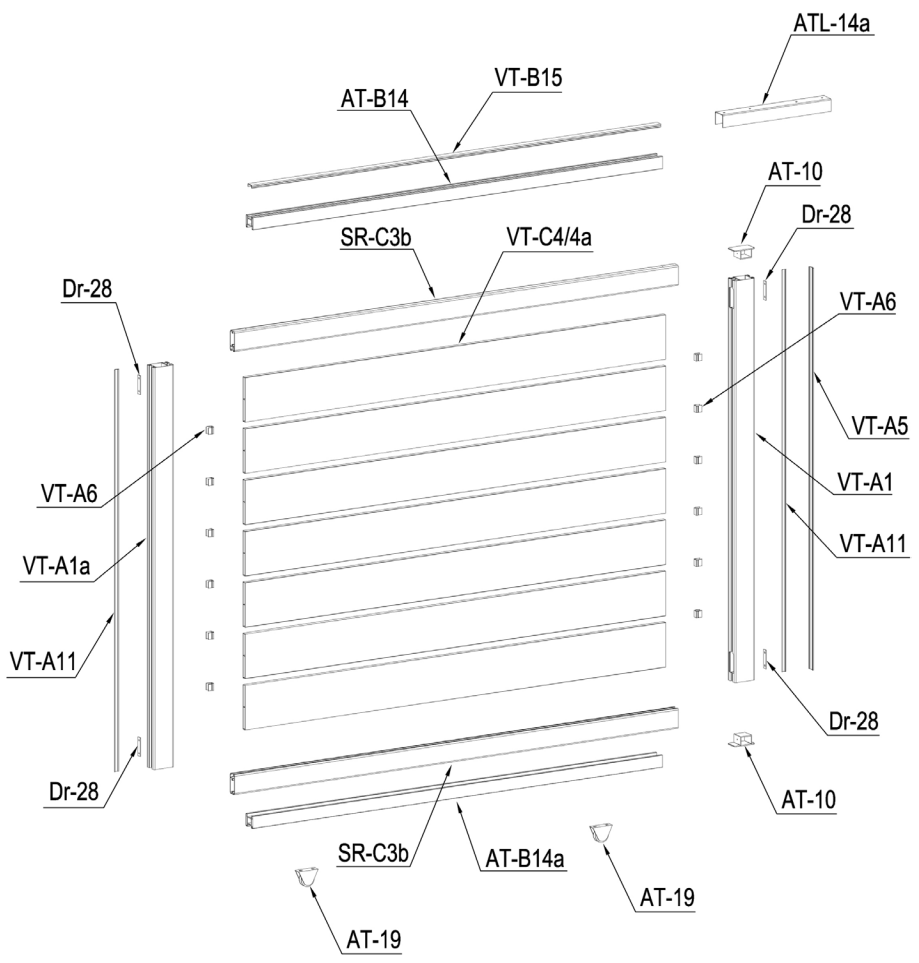

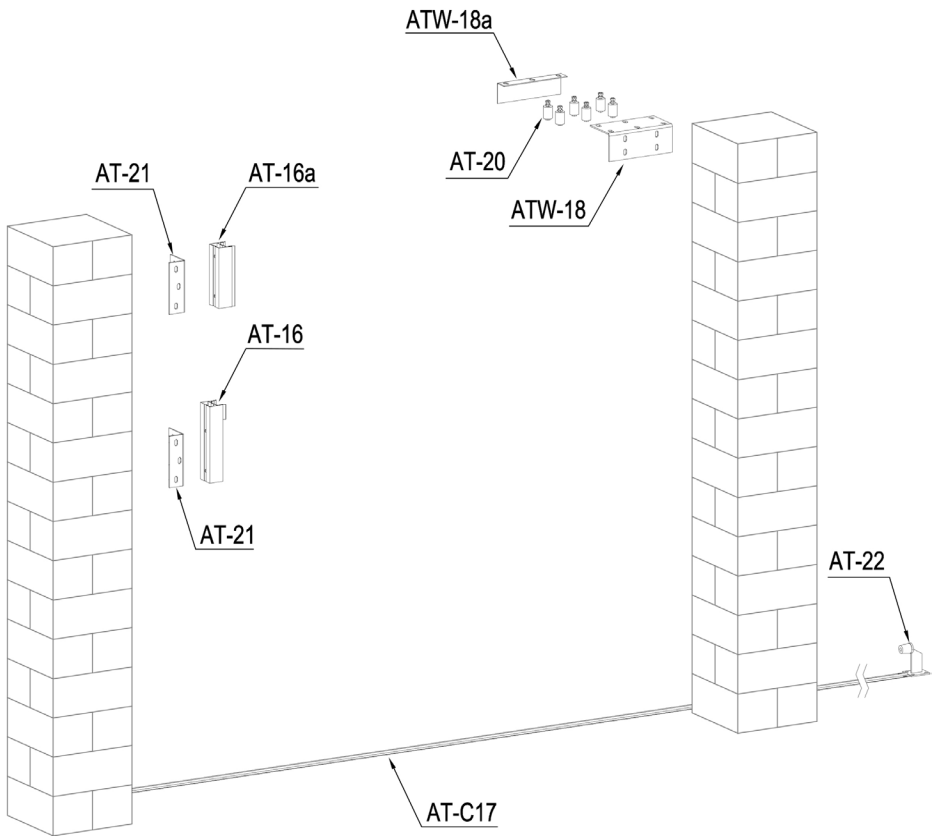



































Part C.







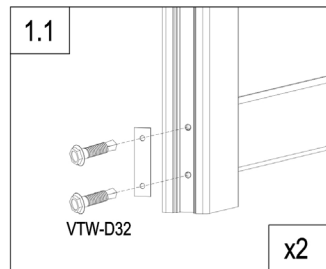
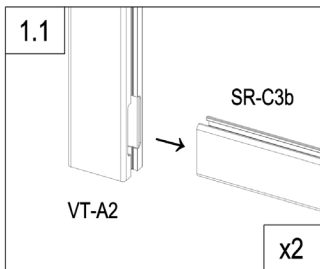
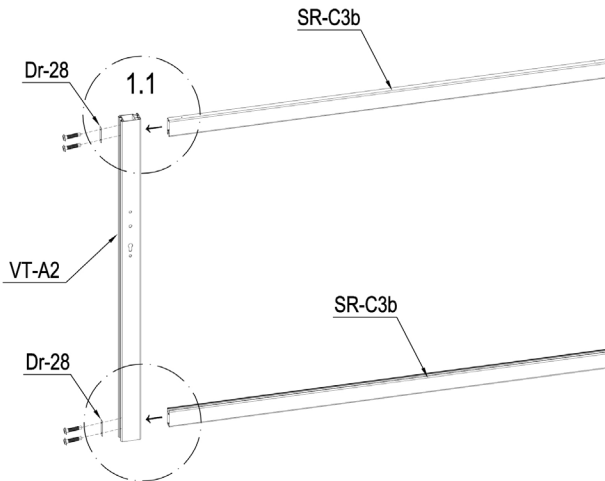

PART LIST

IMAGE	NO.	L.(mm)	QTY	IMAGE	NO.	L.(mm)	QTY
	VT-A1a	1395	4		AT-17		4
	VT-A1	1395	1		AT-10		4
	VT-A2	1395	1		Dr-18		1
	SR-B3b	1471	2		Dr-19		1
	SR-C3b	1721	4		Dr-20a		1
	VT-B4	1380	6		Dr-21		1
	VT-C4	1630	12		Dr-22		1
	VT-B4a	1380	1		Dr-25		1
	VT-C4a	1630	2		Dr-25a		2
	VT-A5	1395	1		Dr-27		2
	VT-A5a	372.5	1		ATW-18		1
	SR-A5a	782	1		ATW-18a		1
	VT-A11	1395	6		AT-19		6
	VT-A6	23	36		AT-20		6
	AT-A20	1315	2		AT-21		2
	AT-A14	1338	1		AT-22		1
	AT-A14a	1338	1		Dr-28		12
	AT-B14	1588	2		ATW-22J		10
	AT-B14a	1588	2		VTW-D30		4
	VT-A15	1337	1		VTW-D31		14
	VT-B15	1587	2		VTW-D32		46
	AT-16	260	1		VTW-D33		4
	AT-16a	205	1		VTW-D34		114
	AT-C17	1580	6		VTW-D36		4
	ATL-14	1000	2		VTW-D37		12
	ATL-14a	420	4		VTW-D38		60

Part A.



	VT-A2	1
	SR-C3b	2
	Dr-28	2
	VTW-D32	4

Part A.

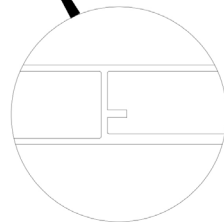
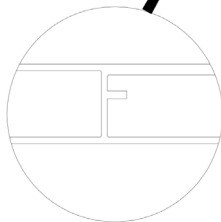
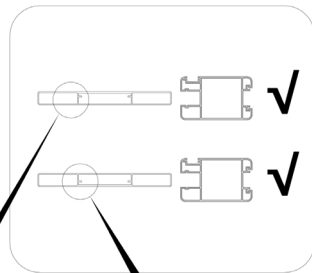
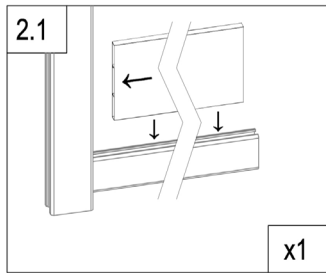
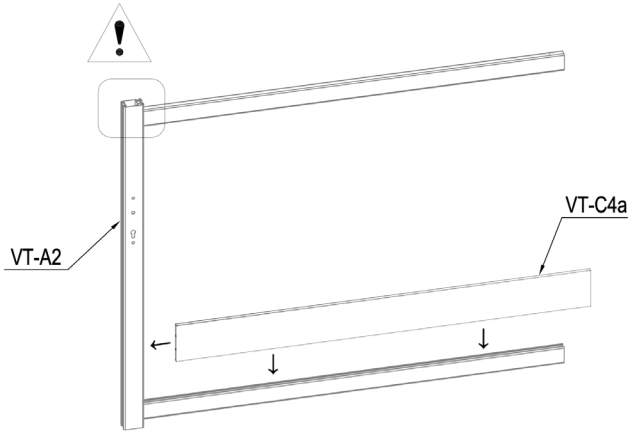

	VT-C4a	1
---	--------	---

Part A.

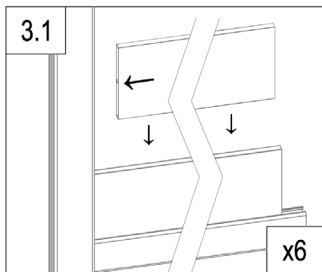
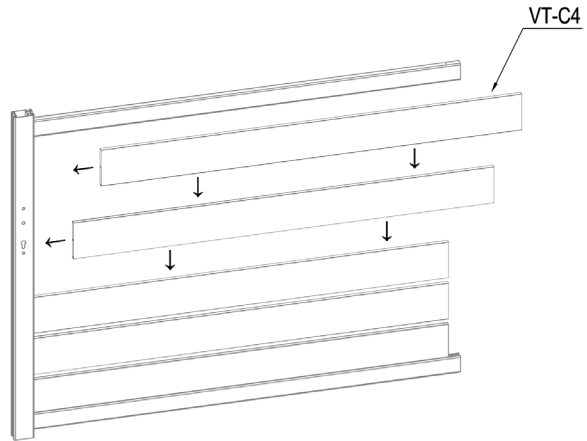

	VT-C4	6
---	-------	---

Part A.

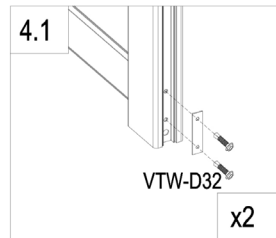
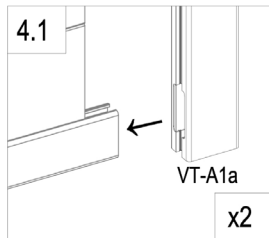
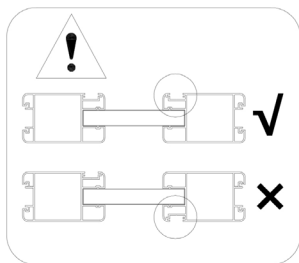
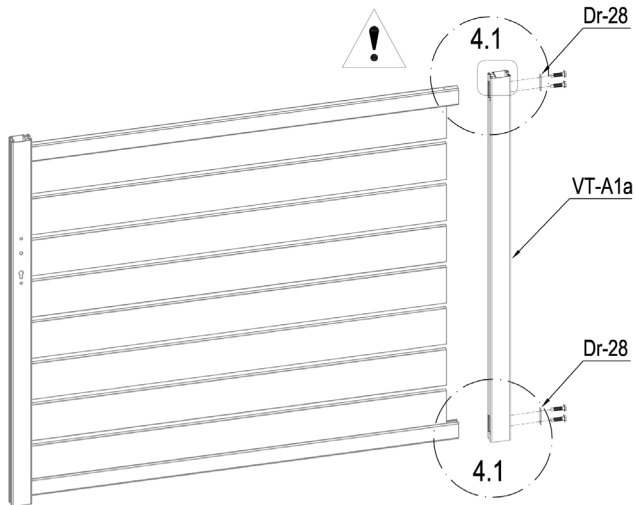

	VT-A1a	1
	Dr-28	2
	VTW-D32	4

Part A.

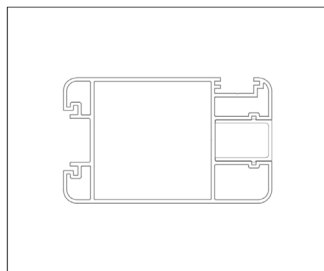
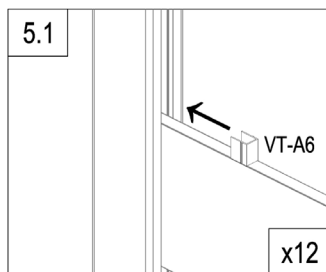
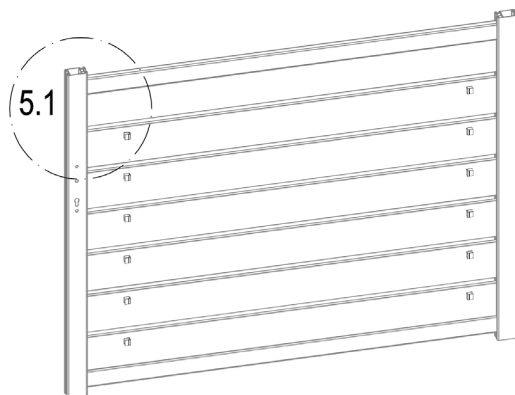

	VT-A6	12
---	-------	----

Part A.

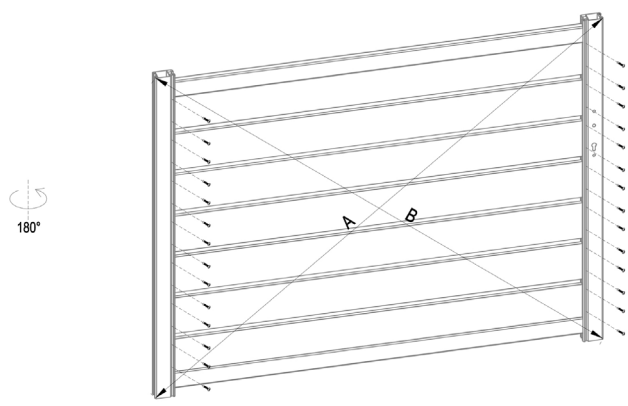

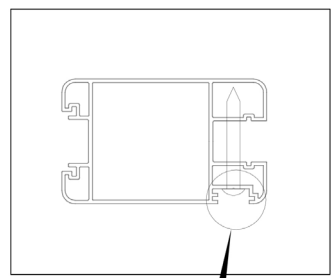
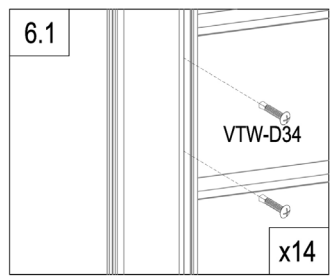

A=B

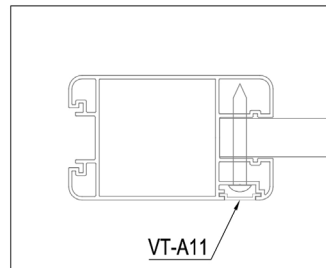
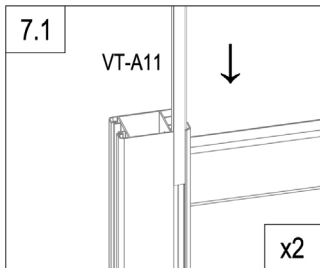
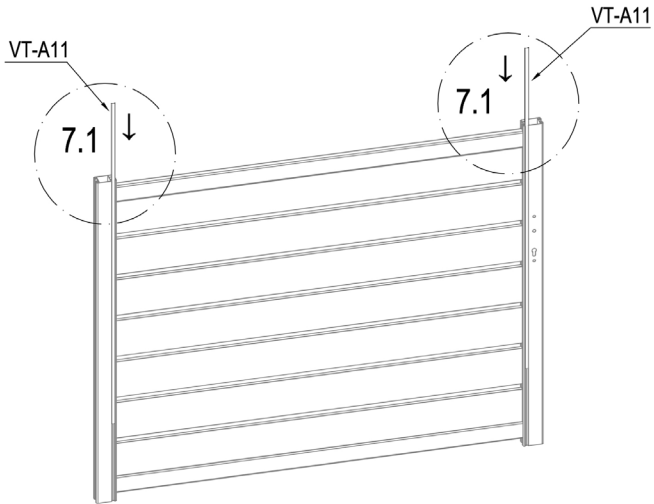

	VTW-D34	28
---	---------	----

Part A.



	VT-A11	2
---	--------	---

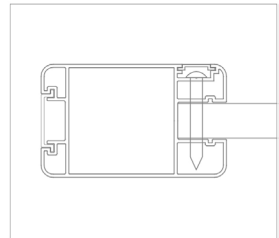
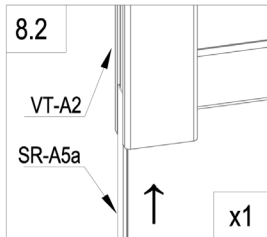
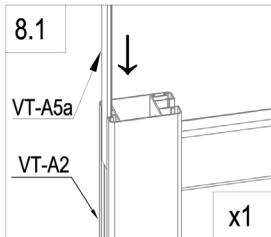
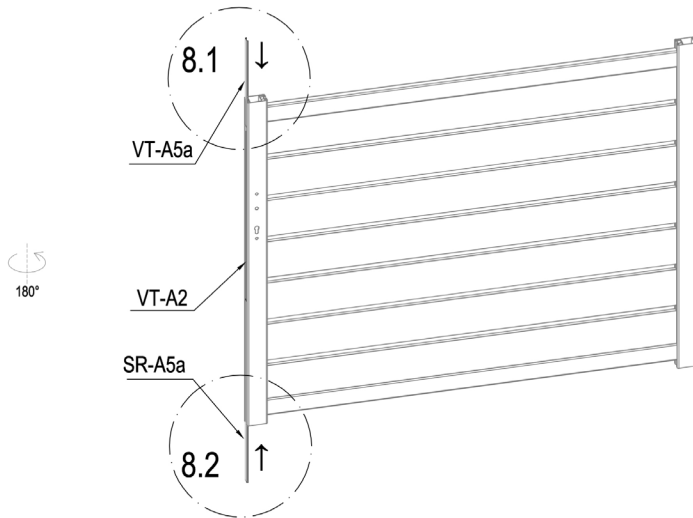

Part A.

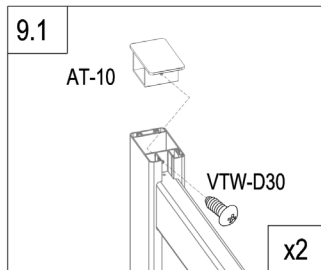
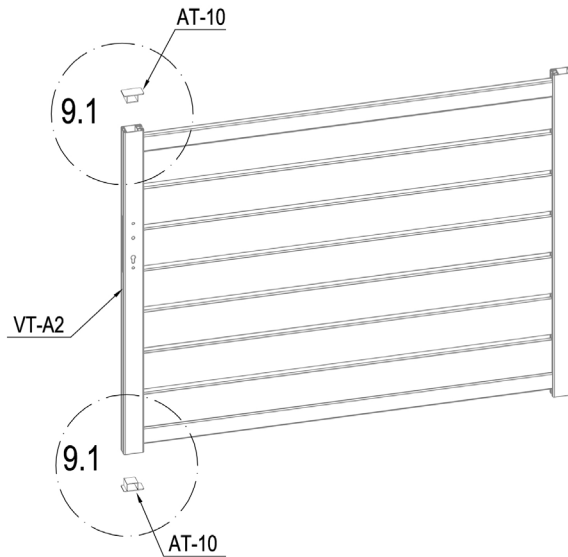

	VT-A5a	1
	SR-A5a	1

Part A.



	AT-10	2
	VTW-D30	2

Part B.

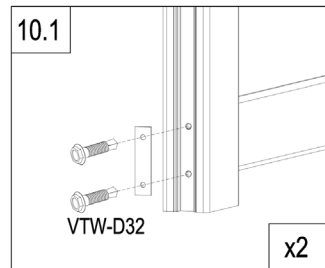
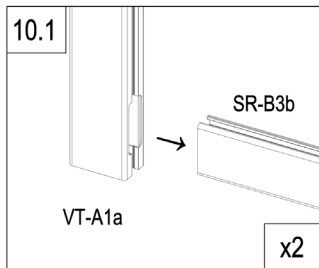
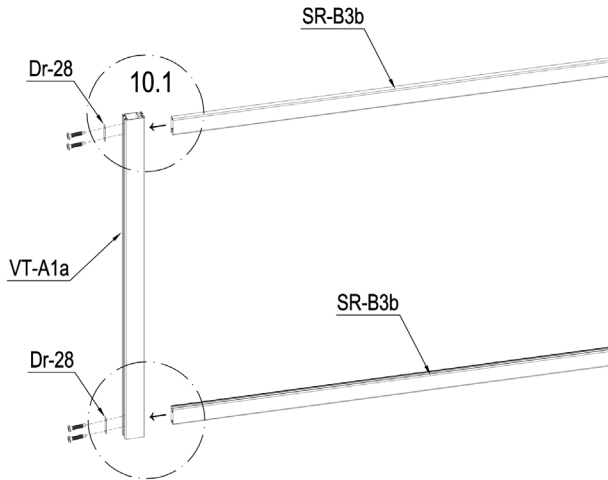

	VT-A1a	1
	SR-B3b	2
	Dr-28	2
	VTW-D32	4

Part B.

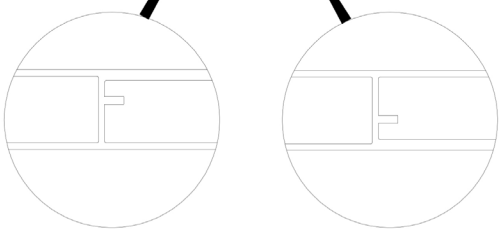
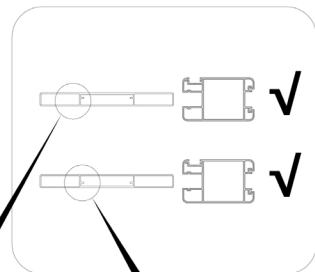
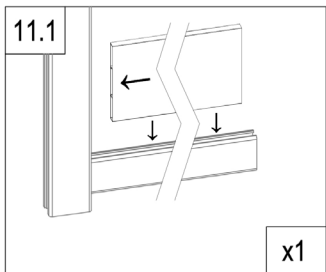
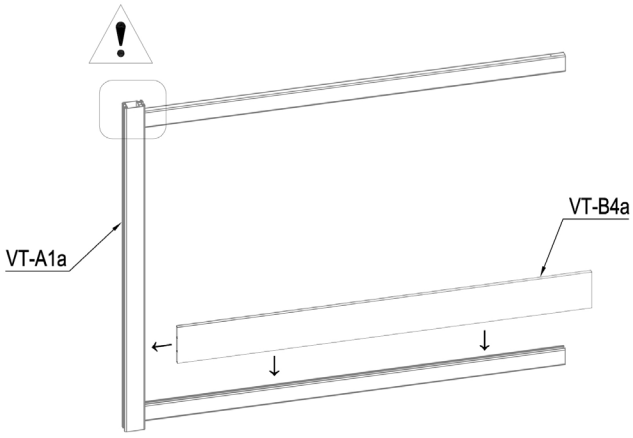

	VT-B4a	1
---	--------	---

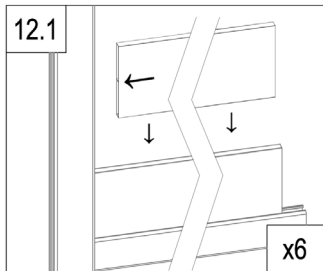
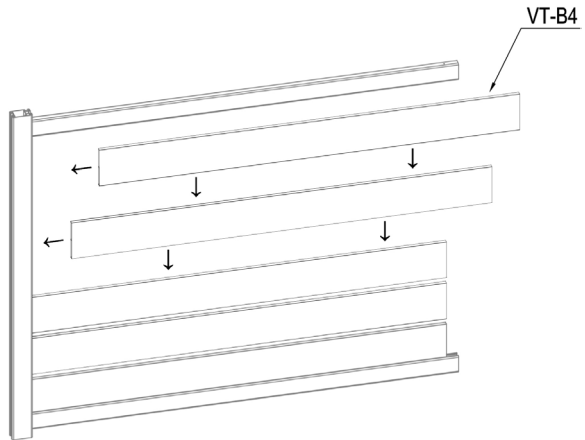

Part B.

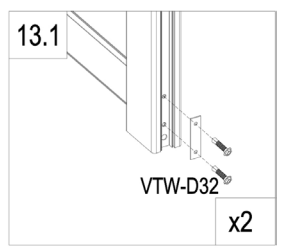
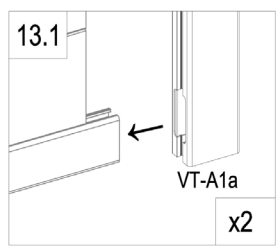
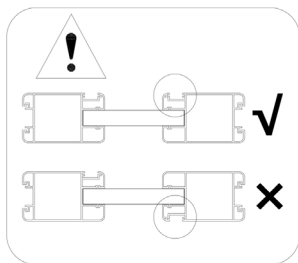
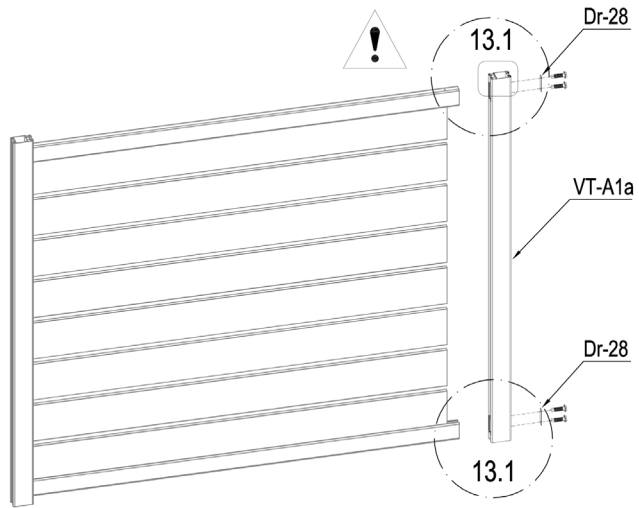

	VT-B4	6
---	-------	---

Part B.



	VT-A1a	1
	Dr-28	2
	VTW-D32	4

Part B.

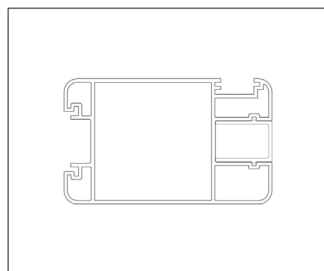
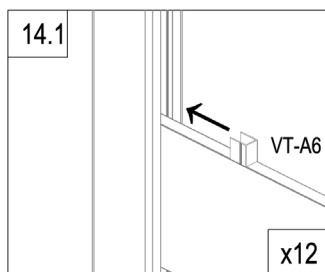
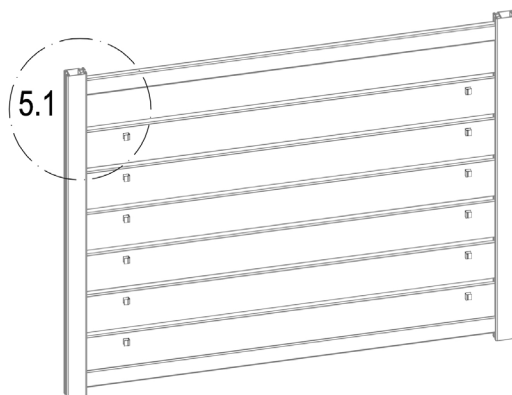

	VT-A6	12
---	-------	----

Part B.

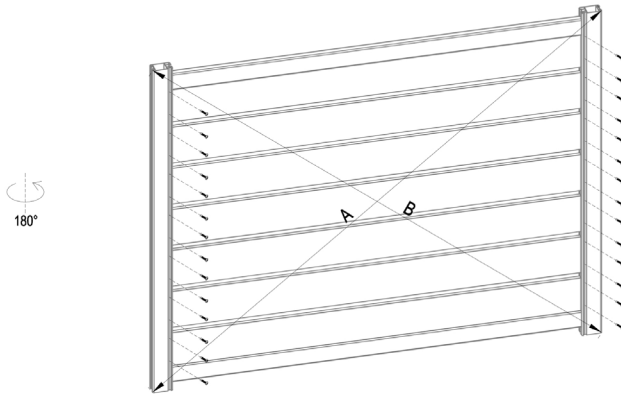

180°

A=B

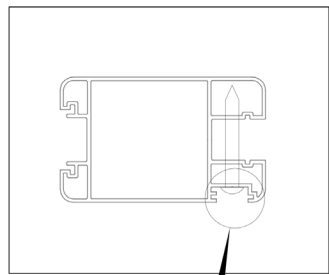
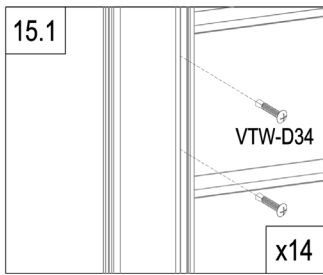

	VTW-D34	28
---	---------	----



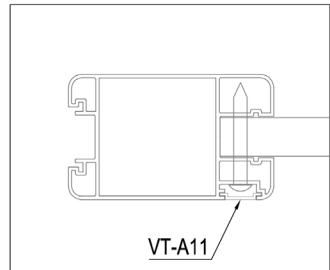
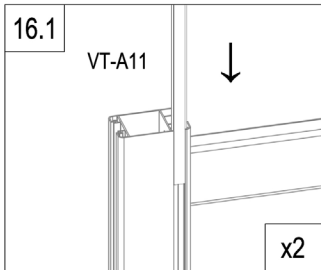
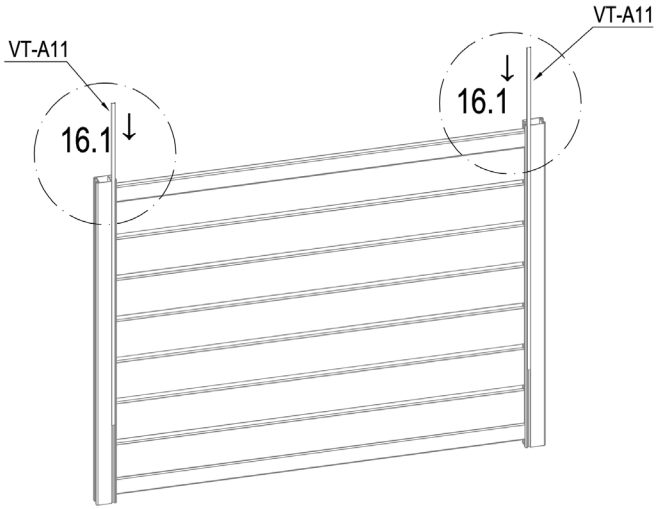

Part B.

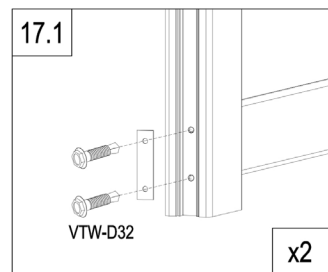
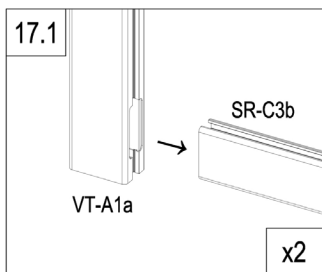
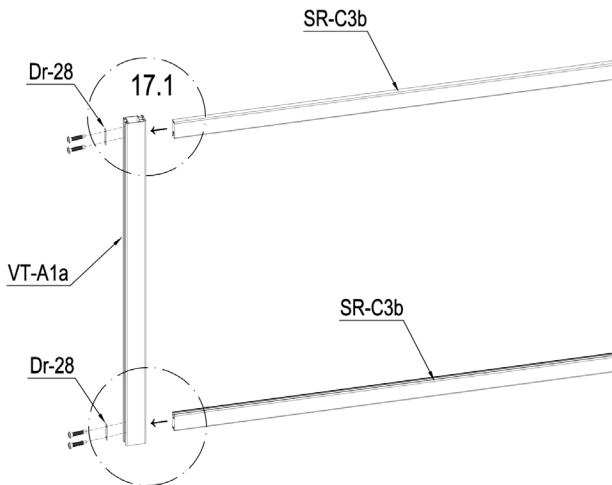

	VT-A11	2
---	--------	---

Part C.



	VT-A1a	1
	SR-C3b	2
	Dr-28	2
	VTW-D32	4

Part C.

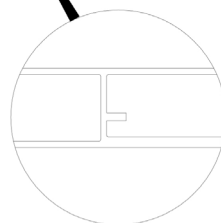
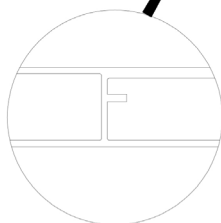
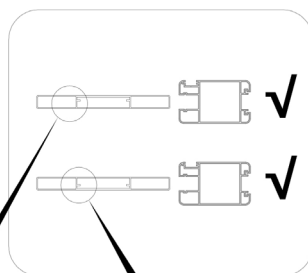
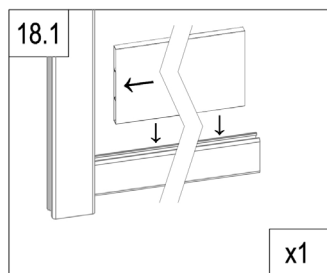
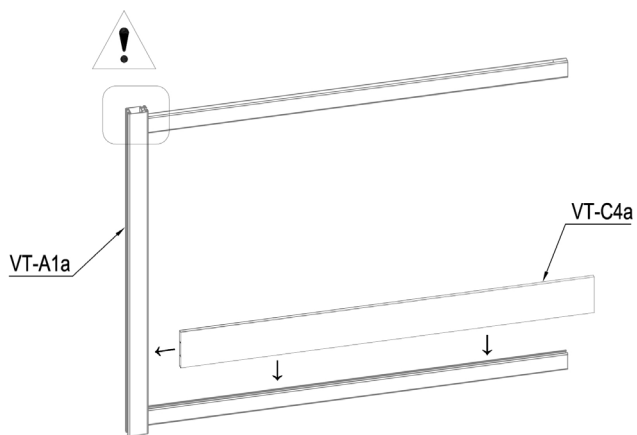

	VT-C4a	1
---	--------	---

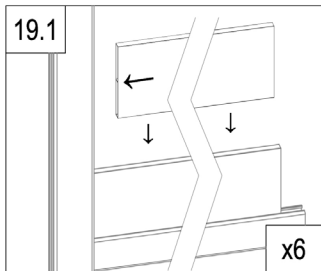
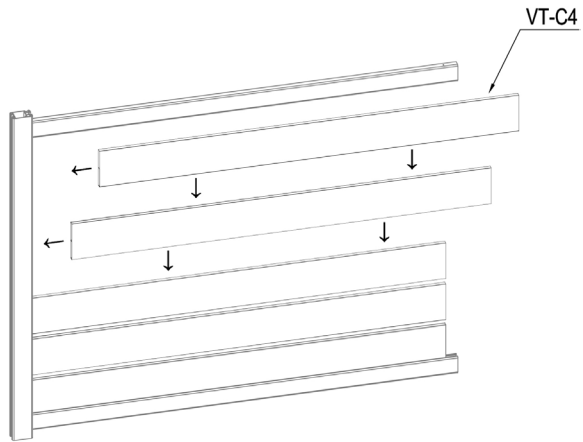

Part C.

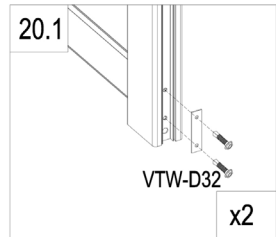
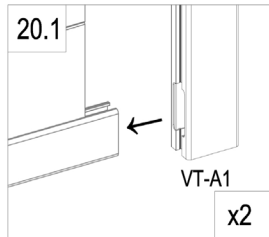
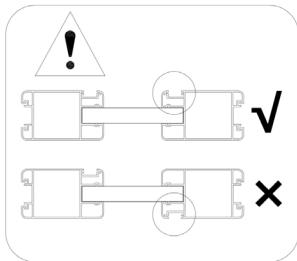
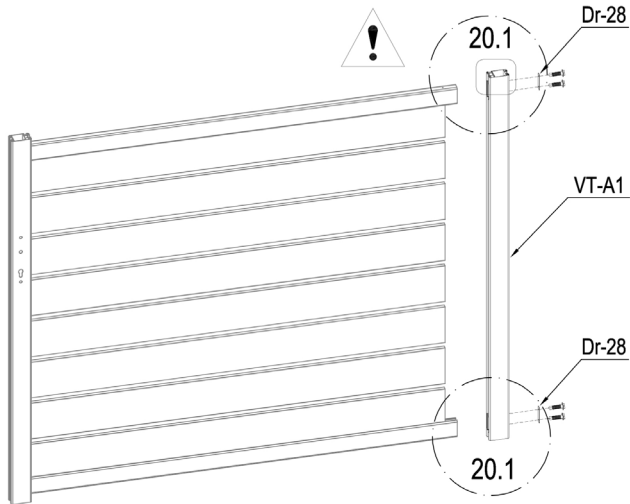

	VT-C4	6
---	-------	---

Part C.



	VT-A1	1
	Dr-28	2
	VTW-D32	4

Part C.

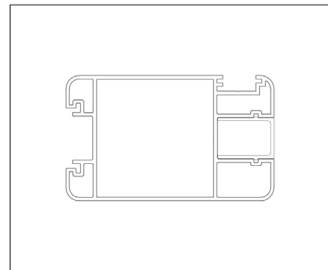
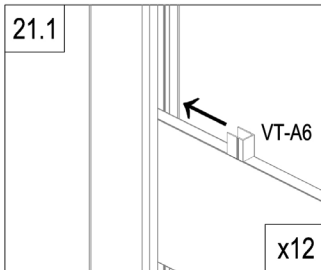
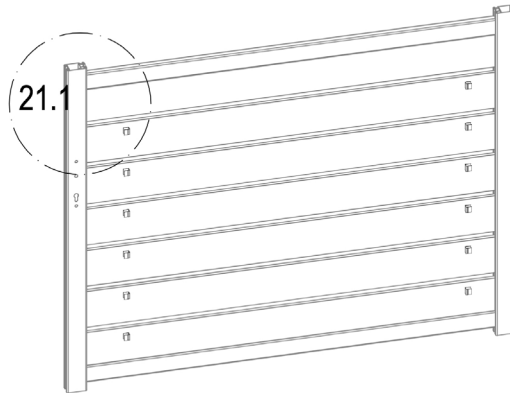

	VT-A6	12
---	-------	----

Part C.

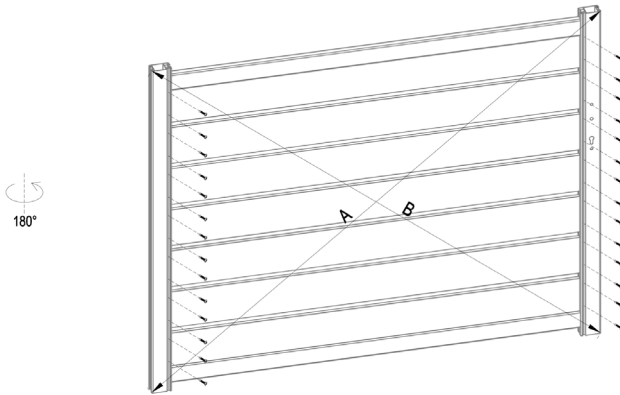

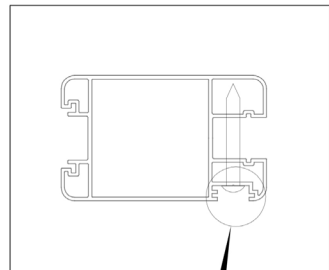
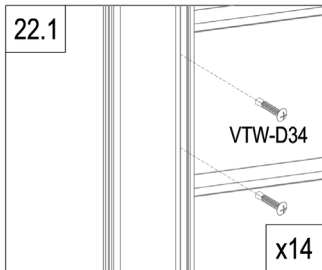

A=B

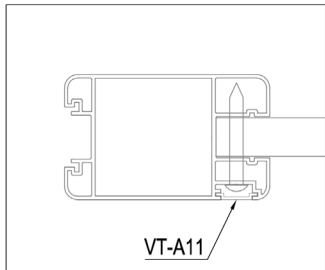
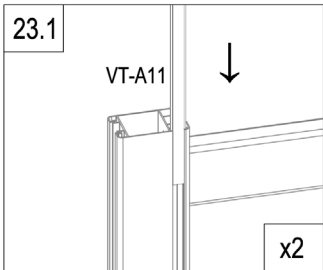
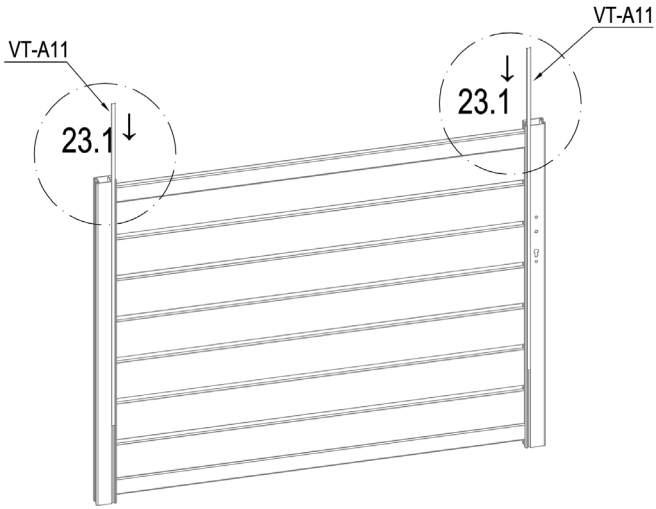

	VTW-D34	28
---	---------	----

Part C.



	VT-A11	2
---	--------	---

Part C.

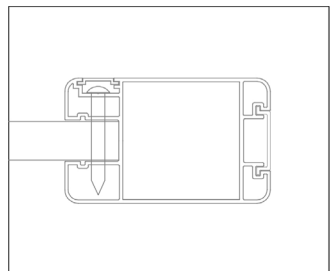
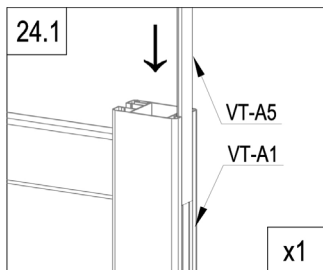
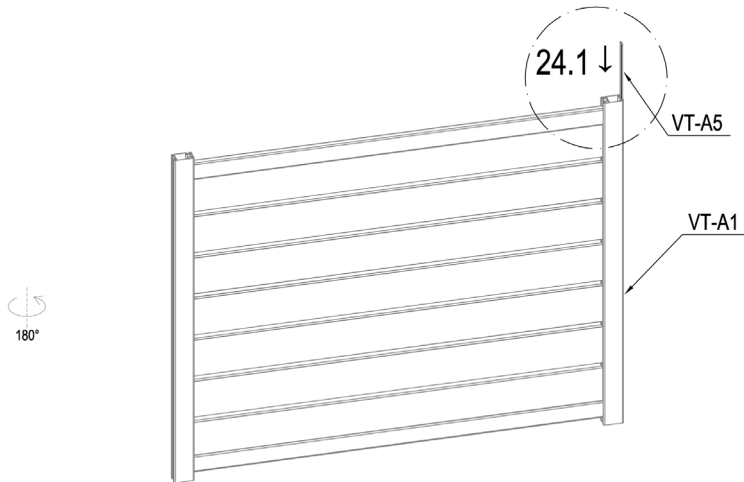



Part C.

]	VT-A5	1
---	-------	---

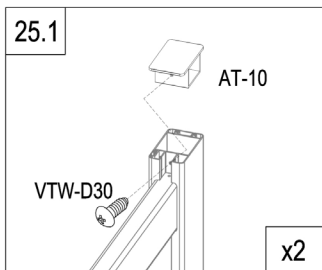
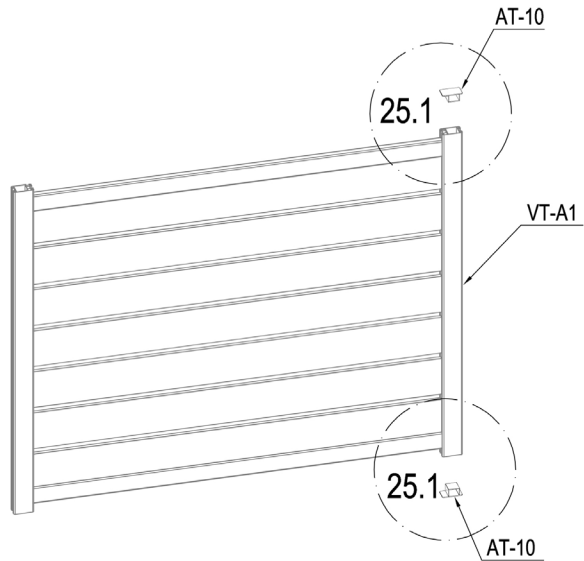

Part C.

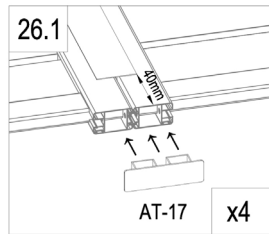
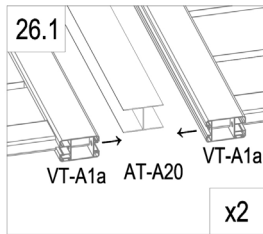
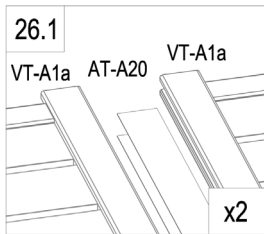
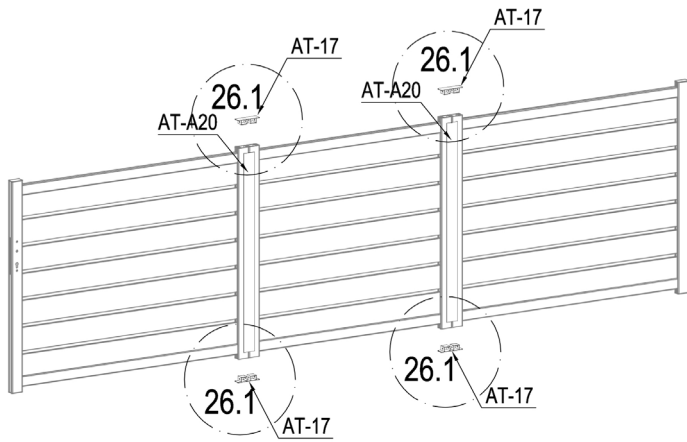

Part C.

	AT-10	2
	VTW-D30	2



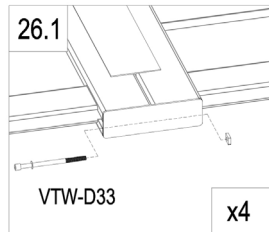

	AT-A20	2
	AT-17	4
	VTW-D33	4

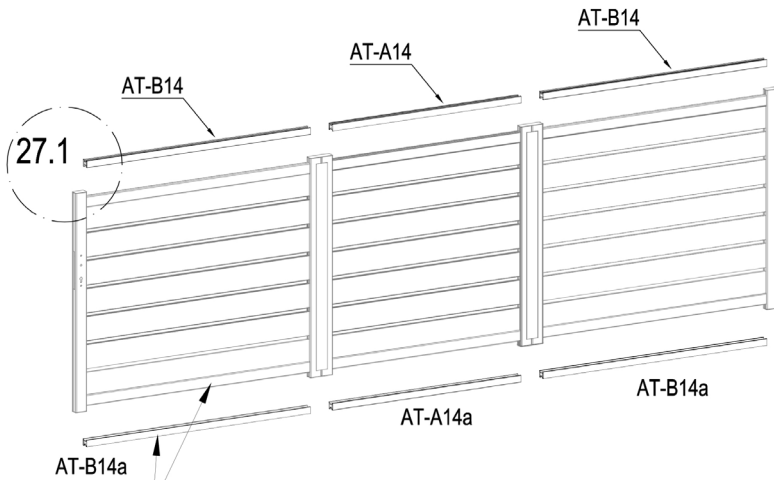

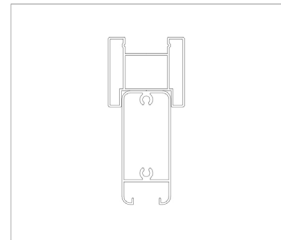
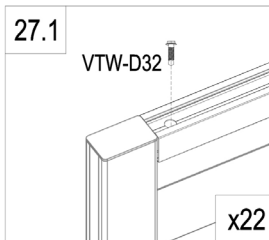
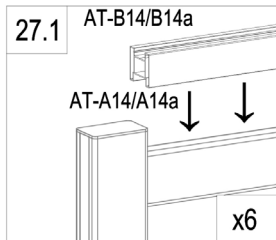

EN: These parts are made for connecting your gate's automation
 FR: Ces pièces sont faites pour relier l'automatisation de votre portail
 DE: Diese Teile sind für den Anschluss der Automatisierung Ihres Tores vorgesehen
 ES: Estas piezas están hechas para conectar la automatización de su puerta
 PT: Estas peças são feitas para ligar a automatização do seu portão
 IT: Queste parti sono realizzate per collegare l'automazione del vostro cancello
 NL: Deze onderdelen zijn gemaakt voor het aansluiten van de automatisering van uw poort.
 PL: Te części są wykonane do podłączenia automatyki bramy.



	AT-B14	2
	AT-B14a	2
	VTW-D32	22

	AT-A14	1
	AT-A14a	1

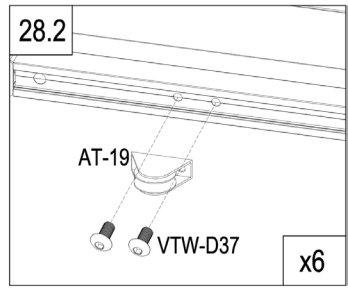
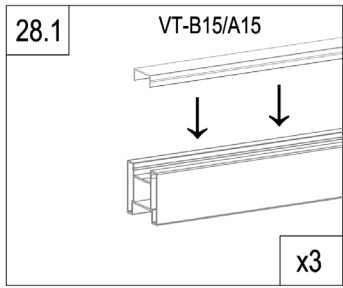
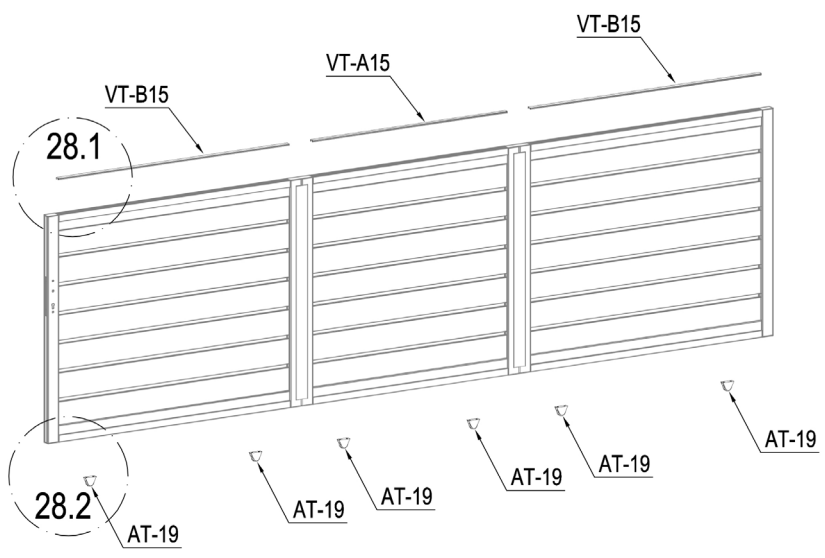

	VT-A15	1
	VT-B15	2
	AT-19	6
	VTW-D37	12

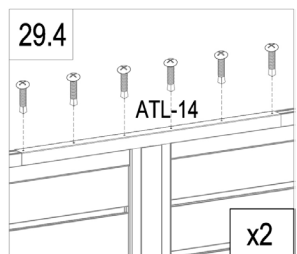
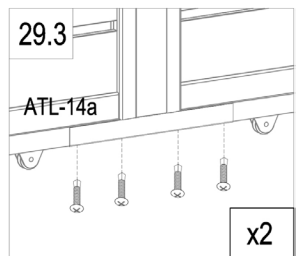
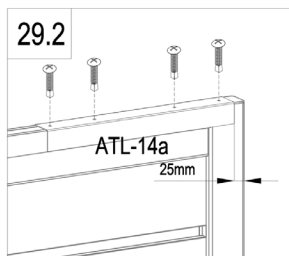
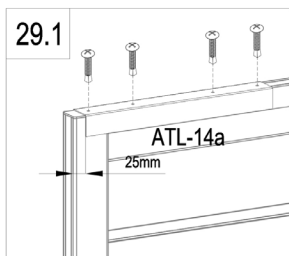
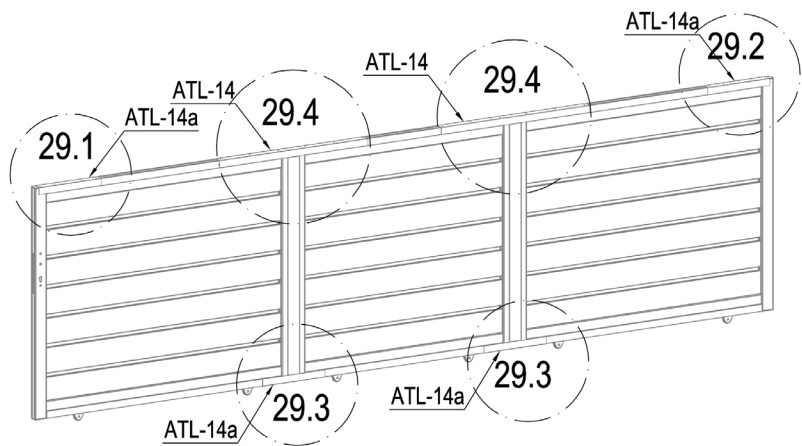

	ATL-14	2
	ATL-14a	4
	VTW-D34	28

Ext.

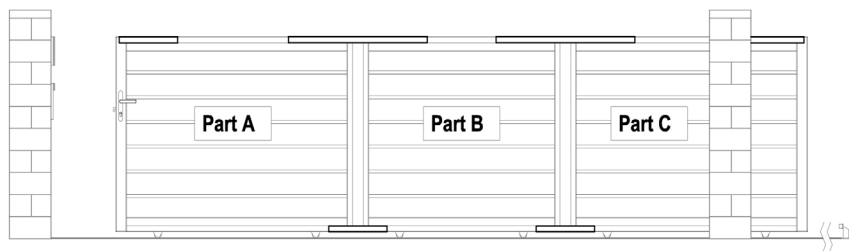

Int.

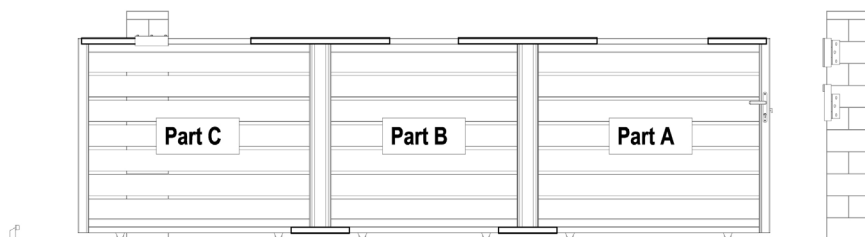

L : P30~36

Ext.

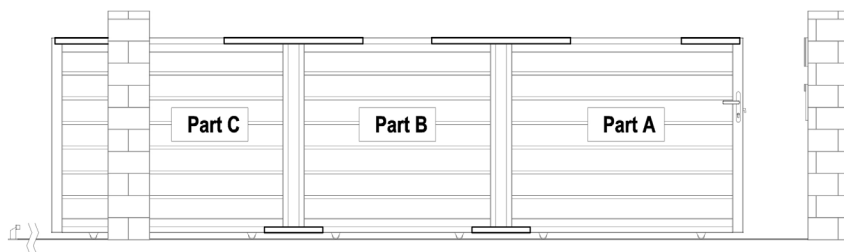

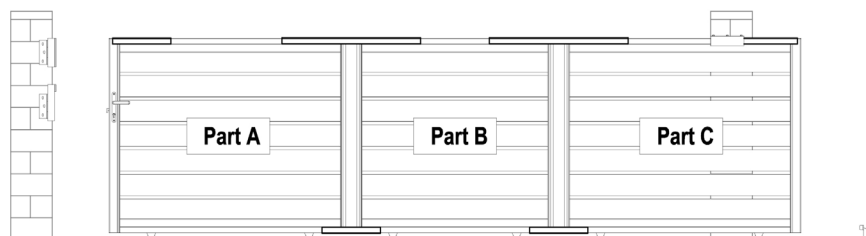

Int.

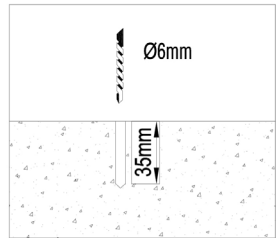
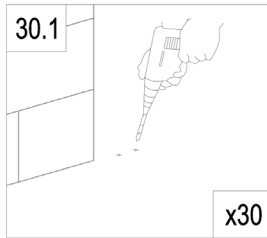
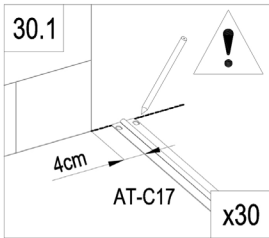
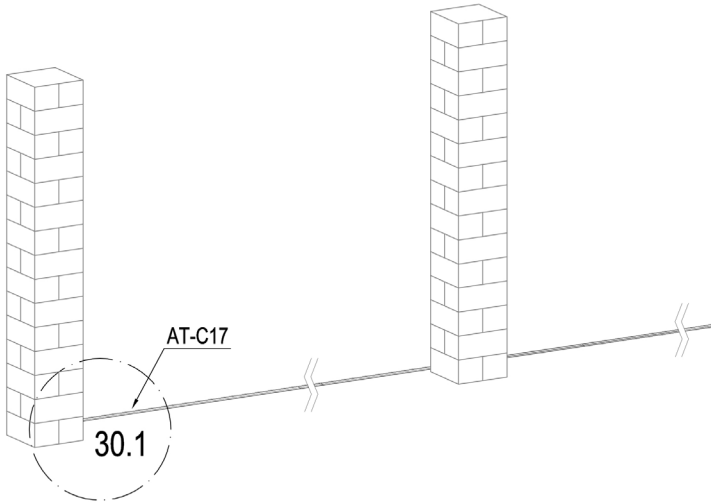

R : P37~43

L



	AT-C17	6
	VTW-D38	60

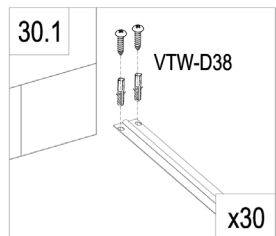

L

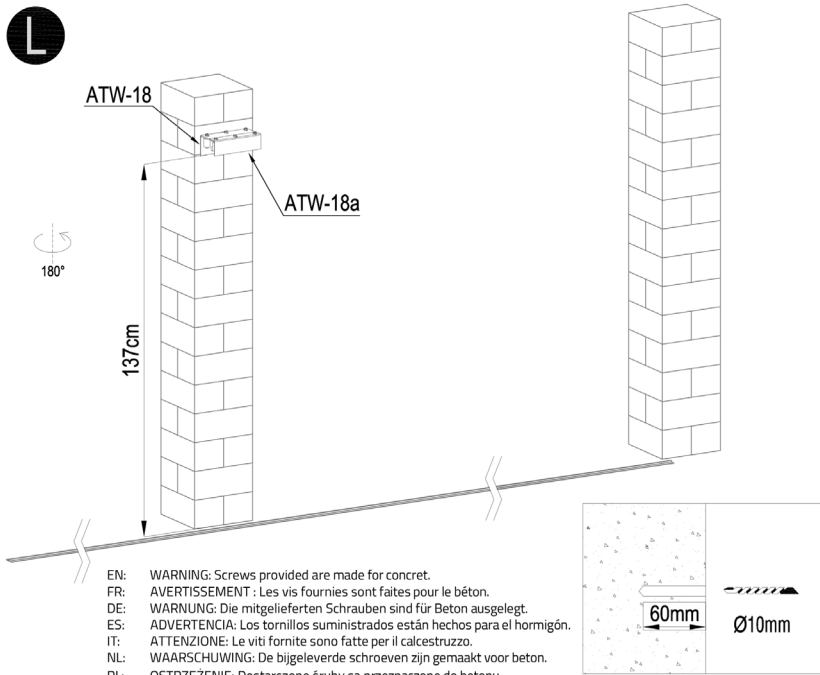

EN: WARNING: Screws provided are made for beton.
 FR: AVERTISSEMENT : Les vis fournies sont faites pour le béton.
 DE: WARNUNG: Die mitgelieferten Schrauben sind für Beton ausgelegt.
 ES: ADVERTENCIA: Los tornillos suministrados están hechos para el hormigón.
 IT: ATTENZIONE: Le viti fornite sono fatte per il calcestruzzo.
 NL: WAARSCHUWING: De bijgeleverde schroeven zijn gemaakt voor beton.
 PL: OSTRZEZENIE: Dostarczone śruby są przeznaczone do betonu.
 PT: AVISO: Os parafusos fornecidos são feitos para betão.

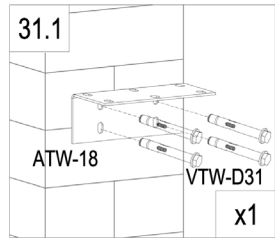
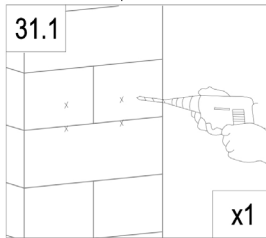
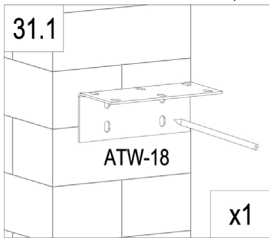

	ATW-18	1
	ATW-18a	1
	AT-20	6
	VTW-D31	4

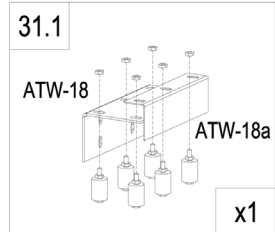
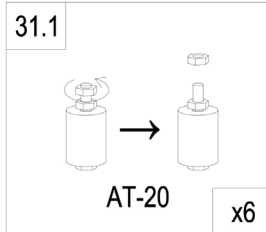

L

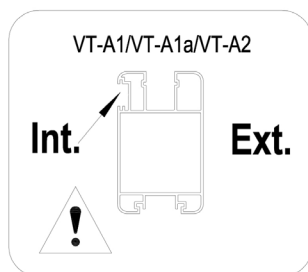
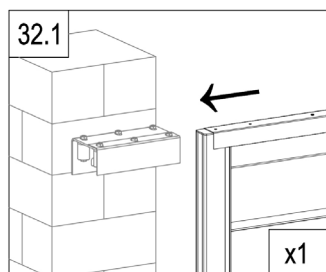
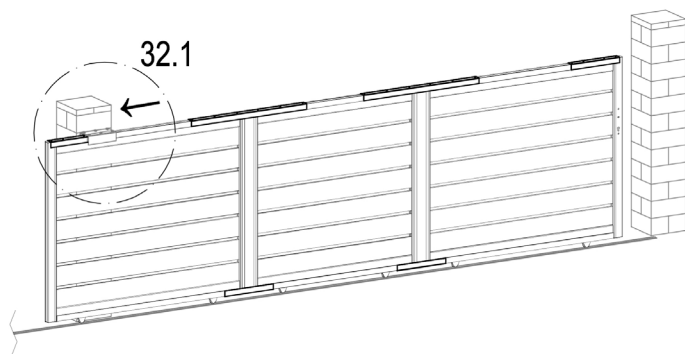

L

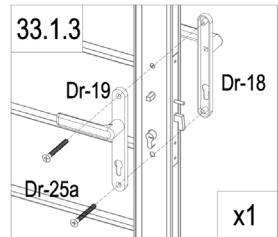
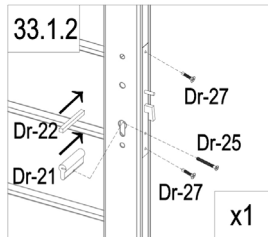
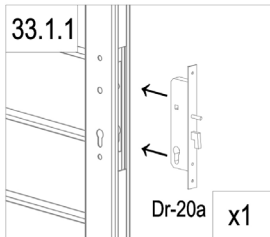
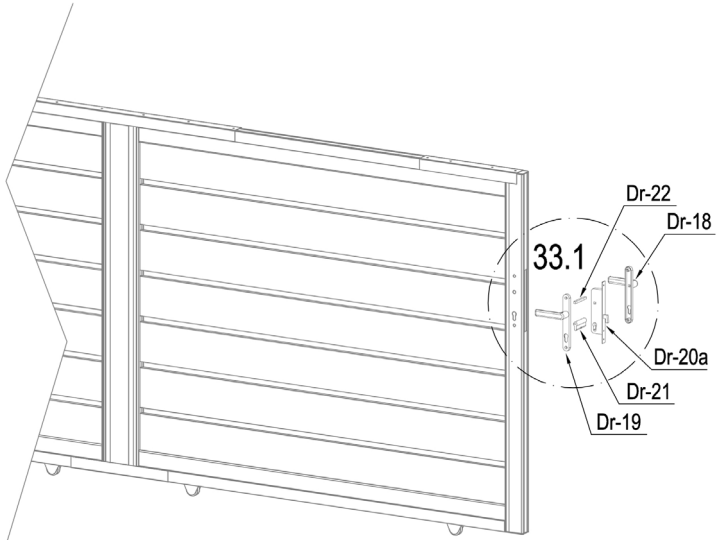

	Dr-20a	1
	Dr-21	1
	Dr-22	1
	Dr-25	1

	Dr-18	1
	Dr-19	1
	Dr-25a	2
	Dr-27	2



EN: WARNING: Screws provided are made for concret.
 FR: AVERTISSEMENT : Les vis fournies sont faites pour le béton.
 DE: WARNUNG: Die mitgelieferten Schrauben sind für Beton ausgelegt.
 ES: ADVERTENCIA: Los tornillos suministrados están hechos para el hormigón.
 IT: ATTENZIONE: Le viti fornite sono fatte per il calcestruzzo.
 NL: WAARSCHUWING: De bijgeleverde schroeven zijn gemaakt voor beton.
 PL: OSTRZEŻENIE: Dostarczone śruby są przeznaczone do betonu.
 PT: AVISO: Os parafusos fornecidos são feitos para betão.

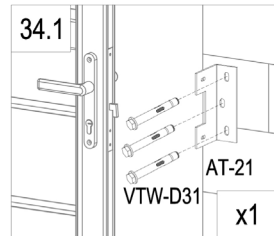
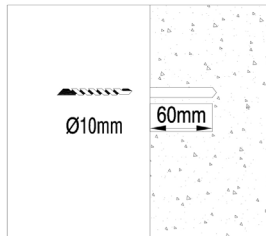
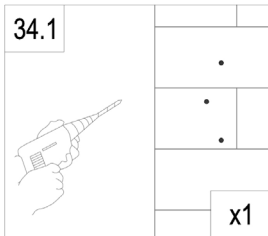
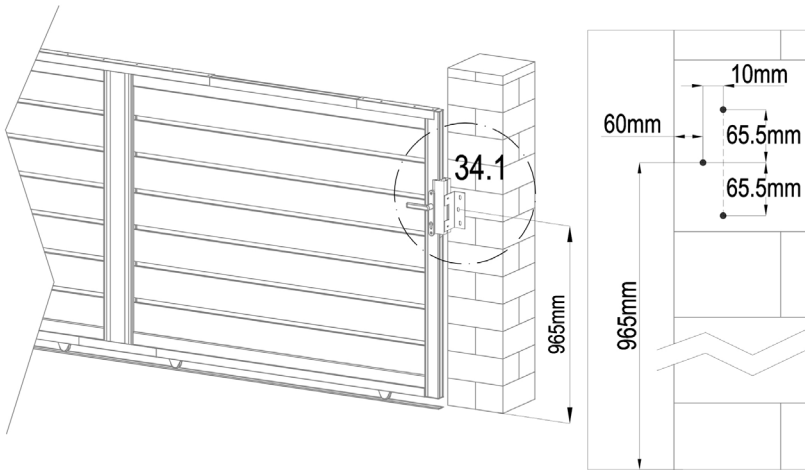

	AT-16	1
	AT-21	1
	VTW-D36	2
	VTW-D31	3
	ATW-22J	3

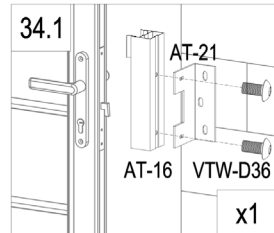
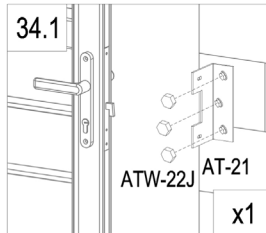

L

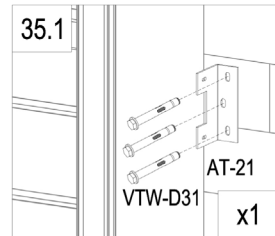
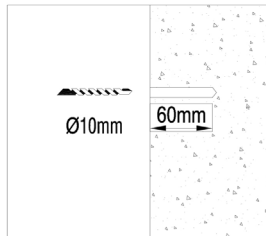
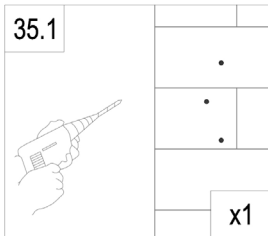
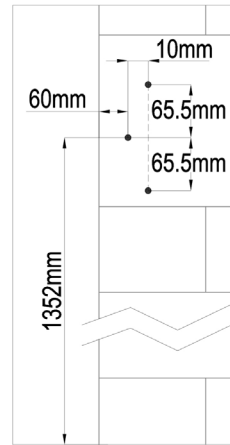
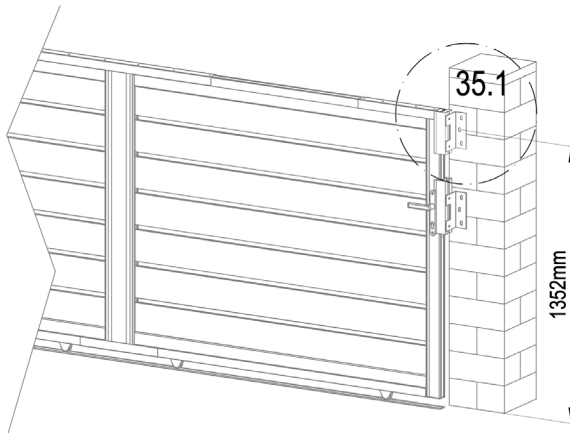

	AT-16a	1
	AT-21	1
	VTW-D36	2
	VTW-D31	3
	ATW-22J	3

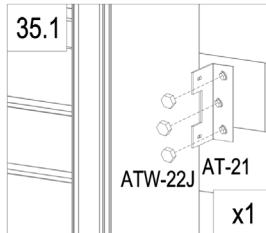

L

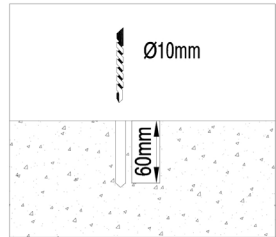
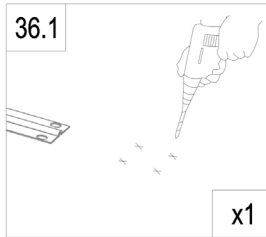
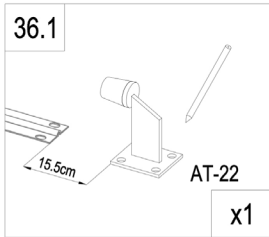
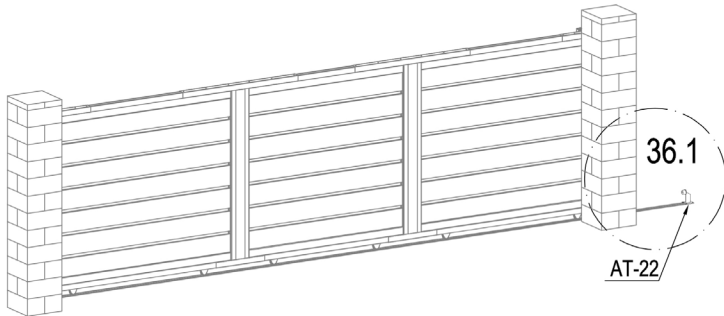

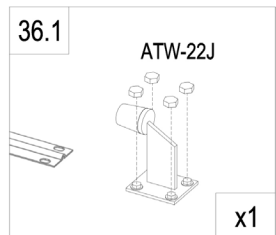
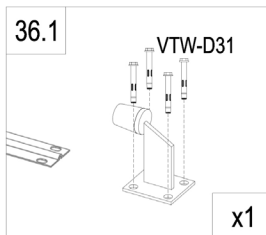

	AT-22	1
	VTW-D31	4
	ATW-22J	4

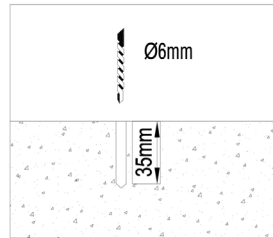
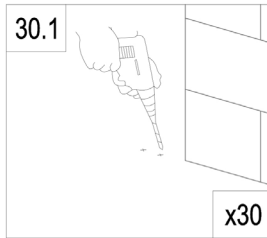
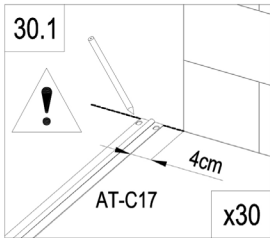
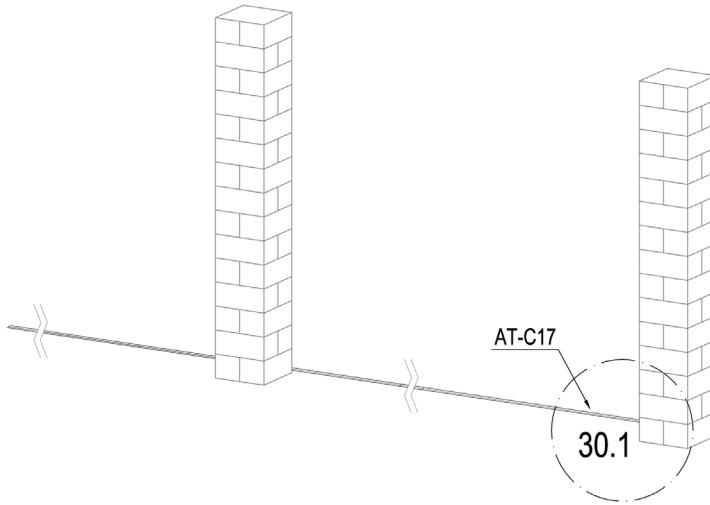

R



	AT-C17	6
	VTW-D38	60

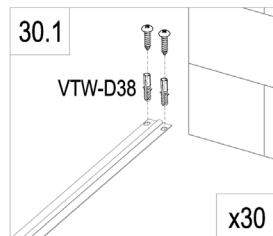

R

180°

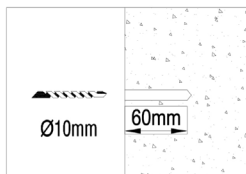
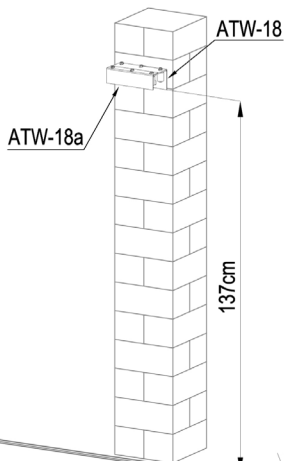

EN: WARNING: Screws provided are made for concrete.
 FR: AVERTISSEMENT : Les vis fournies sont faites pour le béton.
 DE: WARNUNG: Die mitgelieferten Schrauben sind für Beton ausgelegt.
 ES: ADVERTENCIA: Los tornillos suministrados están hechos para el hormigón.
 IT: ATTENZIONE: Le viti fornite sono fatte per il calcestruzzo.
 NL: WAARSCHUWING: De bijgeleverde schroeven zijn gemaakt voor beton.
 PL: OSTRZEŻENIE: Dostarczone śruby są przeznaczone do betonu.
 PT: AVISO: Os parafusos fornecidos são feitos para betão.

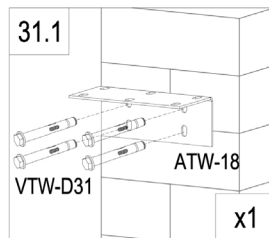
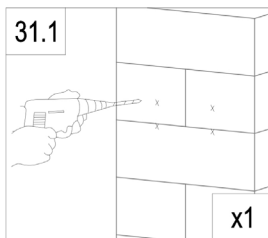
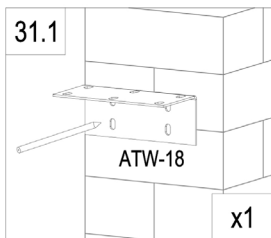

	ATW-18	1
	ATW-18a	1
	AT-20	6
	VTW-D31	4

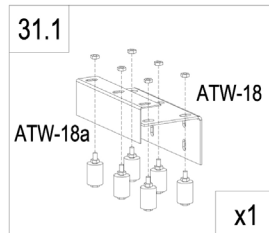
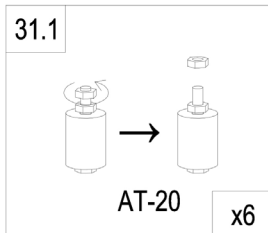

R

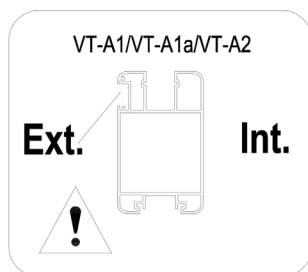
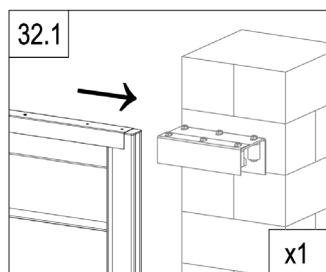
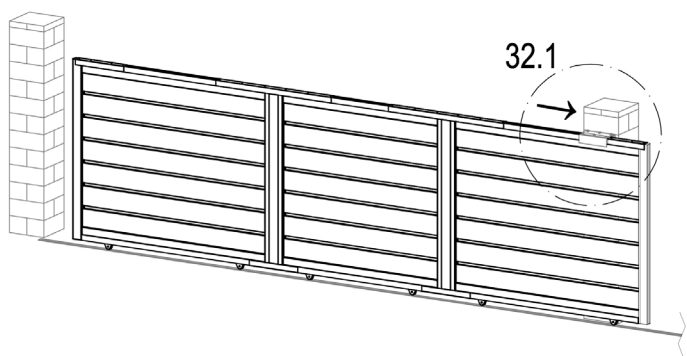

R

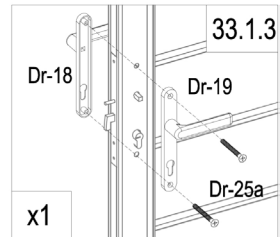
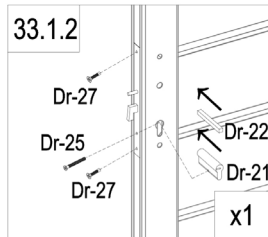
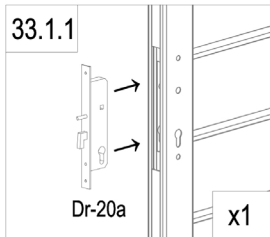
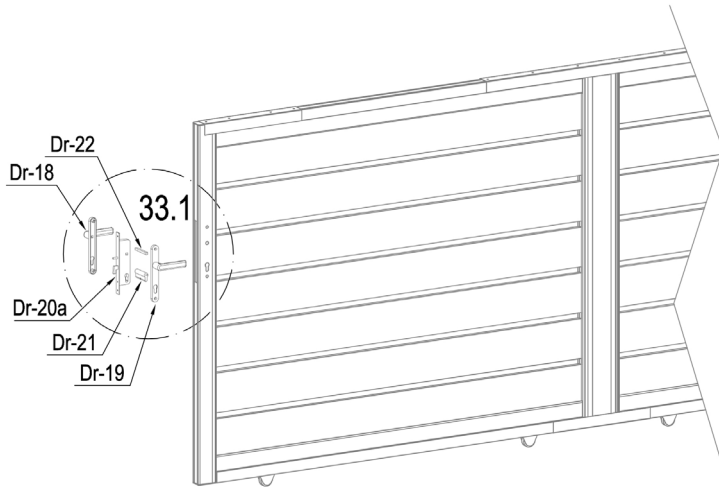

	Dr-20a	1
	Dr-21	1
	Dr-22	1
	Dr-25	1

	Dr-18	1
	Dr-19	1
	Dr-25a	2
	Dr-27	2



EN: WARNING: Screws provided are made for concret.
 FR: AVERTISSEMENT : Les vis fournies sont faites pour le béton.
 DE: WARNUNG: Die mitgelieferten Schrauben sind für Beton ausgelegt.
 ES: ADVERTENCIA: Los tornillos suministrados están hechos para el hormigón.
 IT: ATTENZIONE: Le viti fornite sono fatte per il calcestruzzo.
 NL: WAARSCHUWING: De bijgeleverde schroeven zijn gemaakt voor beton.
 PL: OSTRZEŻENIE: Dostarczone śruby są przeznaczone do betonu.
 PT: AVISO: Os parafusos fornecidos são feitos para betão.

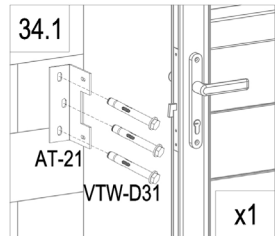
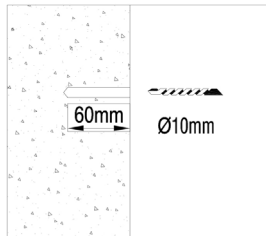
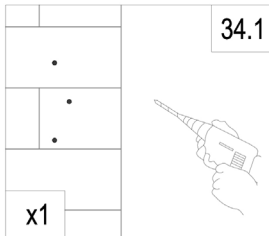
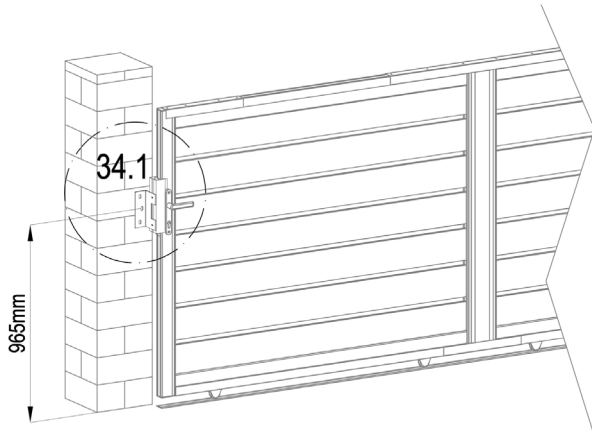
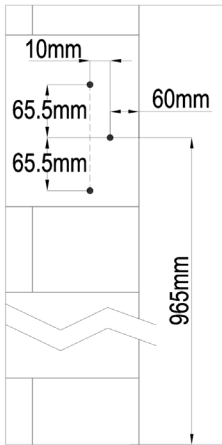



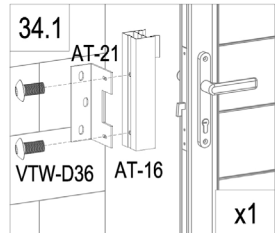
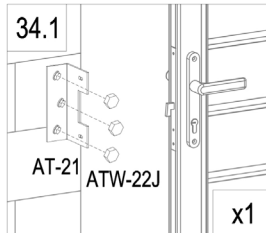

	AT-16	1
	AT-21	1
	VTW-D36	2
	VTW-D31	3
	ATW-22J	3

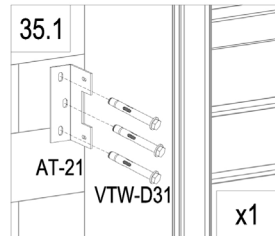
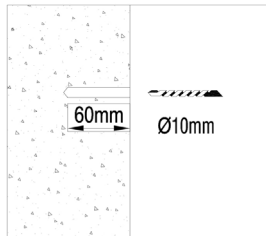
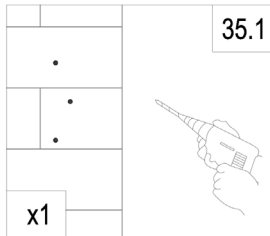
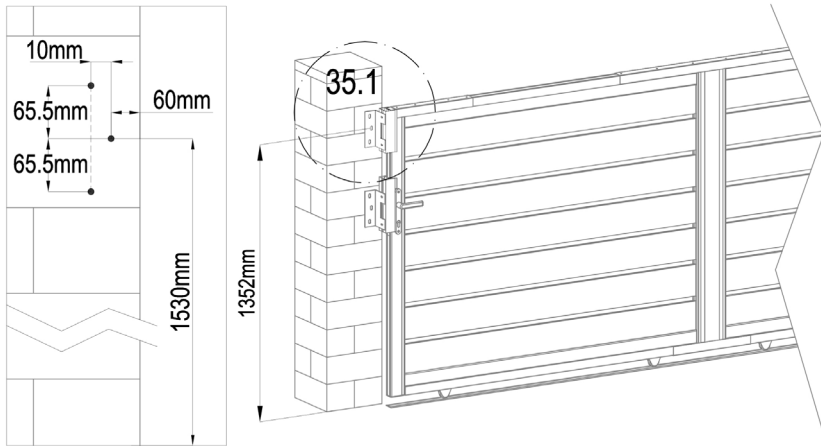

R



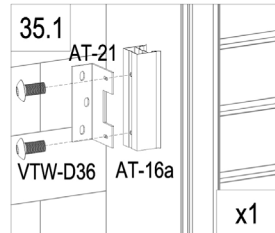
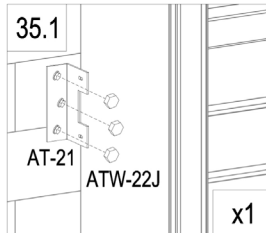

	AT-16a	1
	AT-21	1
	VTW-D36	2
	VTW-D31	3
	ATW-22J	3

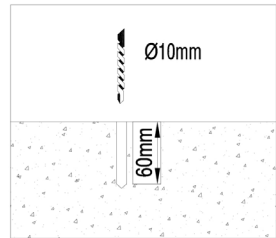
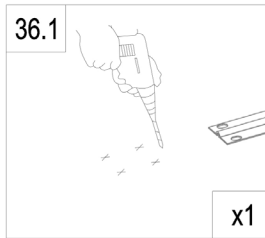
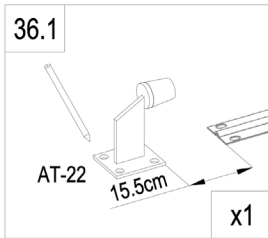
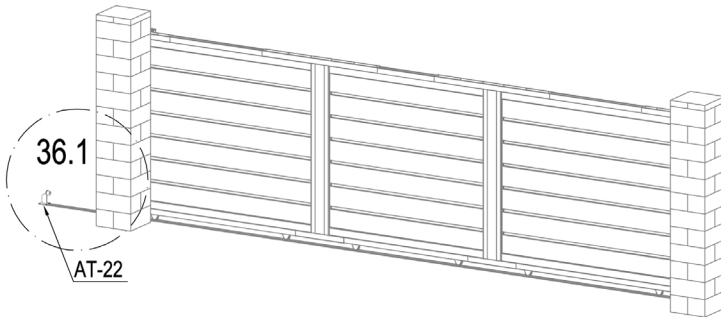

R



	AT-22	1
	VTW-D31	4
	ATW-22J	4

